

NEW BUCK CORPORATION MODEL 1130 CONTEMPORARY VENT-FREE GAS HEATER



WARNING: If the information in this manual is not followed exactly, a fire or explosion may result causing property damage, personal injury or loss of life.

- Do not store or use gasoline or other flammable vapors and liquids in vicinity of this or any other appliance.

WHAT TO DO IF YOU SMELL GAS

- Do not try to light any appliance.
- Do not touch any electrical switch; do not use any phone in your building.
- Immediately call your gas supplier from a neighbor's phone. Follow gas supplier's instructions.
- If you cannot reach your gas supplier, call fire department.
- Installation and service must be performed by a qualified installer, service agency or gas supplier.

This is an unvented gas-fired heater. It uses air (oxygen) from room in which it is installed. Provisions for adequate air for combustion and ventilation must be provided. Refer to section "Producing Adequate Air For Combustion And Ventilation" page 13.

This appliance may be installed in an aftermarket, permanently located, manufactured (mobile) home, where not prohibited by local codes.

This appliance is only for use with type of gas indicated on rating plate. This appliance is not convertible for use with other gases.

INSTALLER: Leave this manual with the appliance.

CONSUMER: Retain this manual for future reference.

**MANUFACTURED BY NEW BUCK
CORPORATION
200 ETHAN ALLEN DRIVE, PO BOX 69
SPRUCE PINE, N.C. 28777
www.buckstove.com**

This appliance is intended for supplemental heating.

January 2013

TABLE OF CONTENTS

Safety Information and Warnings	3
Product Identification.....	6
Product Features.....	7
Unpacking	7
Installation.....	9
Producing Adequate Ventilation Air for Combustion and Ventilation	13
Producing Adequate Ventilation Air for Combustion and Ventilation From Inside Building ...	15
Producing Adequate Ventilation Air for Combustion and Ventilation From Outdoors	16
Gas Connection	17
Connecting to Gas Supply	18
Gas Pressure Check.....	20
Log Placement	21
Lighting Instructions	22
Flame Check	26-27
Inspecting Pilot	26-27
Burner Flame Pattern	26-27
Wiring Diagram	28
Cleaning and Maintenance.....	30
Troubleshooting	32
Technical Service.....	29
Parts List & Blown up View	36-40
Warranty	41

SAFETY INFORMATION WARNINGS

IMPORTANT: READ THIS OWNER'S MANUAL CAREFULLY AND COMPLETELY BEFORE TRYING TO ASSEMBLE, OPERATE OR SERVICE THIS APPLIANCE. IMPROPER USE OF THESE LOGS CAN CAUSE SERIOUS INJURY OR DEATH FROM BURNS, FIRE, EXPLOSION AND CARBON MONOXIDE POISONING.

- **NOTE: When burning any unit or appliance that combusts fuel for heat, such as coal, oil, wood or natural and (L.P.) liquid petroleum gas. We highly recommend the use of smoke and carbon monoxide detectors in your home.**

Early signs of carbon monoxide poisoning resemble the flu, with headaches, dizziness and/or nausea. If you have these signs, heater may not be working properly. Get fresh air at once! Have burner serviced. Some people-pregnant women, persons with heart or lung disease, anemia, those under the influence of alcohol, those at high altitudes-are more affected by carbon monoxide than others. Make certain you understand and read all Warnings. Keep this manual for reference. It is your guide to safe and proper operation of this heater and logs.

CAUTION: Strong drafts, such as a ceiling fan placed directly in front of heater (pulling from either direction) may create sooting. Sooting will discolor walls.

1. The installation must conform with local codes or in absence of local codes, with *National Fuel Gas Code, ANSI Z223.1/NFPA54*.
2. This appliance may be installed in an After-Market* Manufactured (Mobile) Home, where not prohibited by state or local codes.

* (After-Market: Completion of sale, not for purpose of resale from manufacturer.)

This appliance is only for use with type of gas indicated on rating plate. This appliance is not convertible for use with other gases.

NOTE: See Page 13, for "Producing Adequate Air For Combustion And Ventilation".

IMPORTANT: VENT-FREE HEATERS ADD MOISTURE TO AIR. ALTHOUGH THIS IS BENEFICIAL, INSTALLING HEATER IN ROOMS WITHOUT ADEQUATE VENTILATION MAY CAUSE MILDEW TO FORM FROM TOO MUCH MOISTURE.

3. Never install this heater:
 - In a recreational vehicle, bathroom.
 - Where curtains, furniture, clothing or other flammable objects are less than 24" from the front of heater
 - In high traffic areas or in windy areas
4. Two models are available. One specific model for propane(LP) and one for natural gas. Use correct type gas for your home. Do not convert from one gas type to another.

NOTE: This appliance complies with ANSI Z21.11.2b-2010 Unvented Room Heater.

WARNING

This appliance is equipped for (natural or propane) gas.
Field conversion is not permitted.

5. If this heater is used with propane gas, do not place propane supply tank (s) inside any structure.
6. What To Do IF You Smell Gas:
 - Shut off gas supply.
 - Do not try to light any appliance.
 - Do not touch any electrical switch; do not use any phone in your building.
 - Immediately call your gas supplier from a neighbor's phone.
 - Follow gas supplier's instructions.
 - If you cannot reach your gas supplier, call the department.
7. When operated for first time, the logs may emit a "paper burning" smell. This smell will gradually diminish and will be totally eliminated after first few hours of operation. Do not use blower at this time.
8. This heater shall not be installed in unusually tight construction unless provisions are provided for adequate combustion and ventilation air. See *Producing Adequate Air For Combustion And Ventilation*, page 13.
9. Surface of gas logs becomes very hot when operating. Keep children and adults away from hot surface. Gas logs will remain hot for sometime after shutdown. Allow surface to cool before touching.
10. Do not place clothing or other flammable material on or near appliance.
11. If equipped, fresh air damper must be closed.
12. Keep appliance area clean and free from combustible materials, gasoline and other flammable flammable vapors and liquids.
13. If burner shuts off, do not relight until you provide fresh outside air. If burner continues to shut off, have unit serviced.
14. Do not use this heater if any part has been under water. Immediately call qualified service technician to inspect room heater and to replace any part of control system and any gas control which has been under water.
15. Turn off heater and let cool before servicing.
16. These logs are made of bonded fiber. When removing logs and base, do not damage bonded material. If the material is damaged extensively, loose fiber dust could be emitted into air.
17. Any safety screen or guard removed for servicing an appliance must be replaced prior to operating heater.
18. This appliance is intended for supplemental heating.
18. **WARNING:** Any change to this heater or its controls can be dangerous.
19. Installation and repairs should be performed by a qualified service person. The appliance should be inspected before use and at least annually by a professional service person. More frequent cleaning may be required due to excessive lint from carpeting, bedding material, etc. It is imperative that control compartments, burners and circulating air passageways of appliance be kept clean.

20. All heater screens must be kept clean when operating gas logs.
21. **WARNING:** Failure to keep primary air opening of burner clean may result in soot and property damage.
22. Do not use this heater for burning trash or cooking. Never place matches, paper, garbage or any other material on top of logs or into flames.
23. Do not install or operate this heater in areas where impurities in air exist (such as tobacco smoke or heavy cooking grease). Particles from impurities may discolor walls.
24. Due to high temperatures, appliance should be located out of traffic and away from furniture and draperies.
25. Children and adults should be alerted to hazards of high surface temperature and should stay away to avoid burns or clothing ignition.
26. Young children should be carefully supervised when they are in same room with appliance.
27. An unvented room heater having an input rating of more than 10,000 Btu per hour shall not be installed in a bathroom or bedroom.
28. The appliance and its appliance main gas valve must be disconnected from the gas supply piping system during any pressure testing of that system at test pressure in excess of 1/2 psi (3.5 kPa).
29. The appliance must be isolated from the gas supply piping system by closing its equipment shut-off valve during any pressure testing of gas supply piping system at test pressures equal to or less than 1/2 psi (3.5 kPa).
30. **WARNING:** Do not allow fans to blow directly into fireplace. Avoid any drafts that alter burner flame patterns.
31. **WARNING:** Do not use a blower insert, heat exchanger insert or other accessory not approved for use with this heater.

PRODUCT IDENTIFICATION

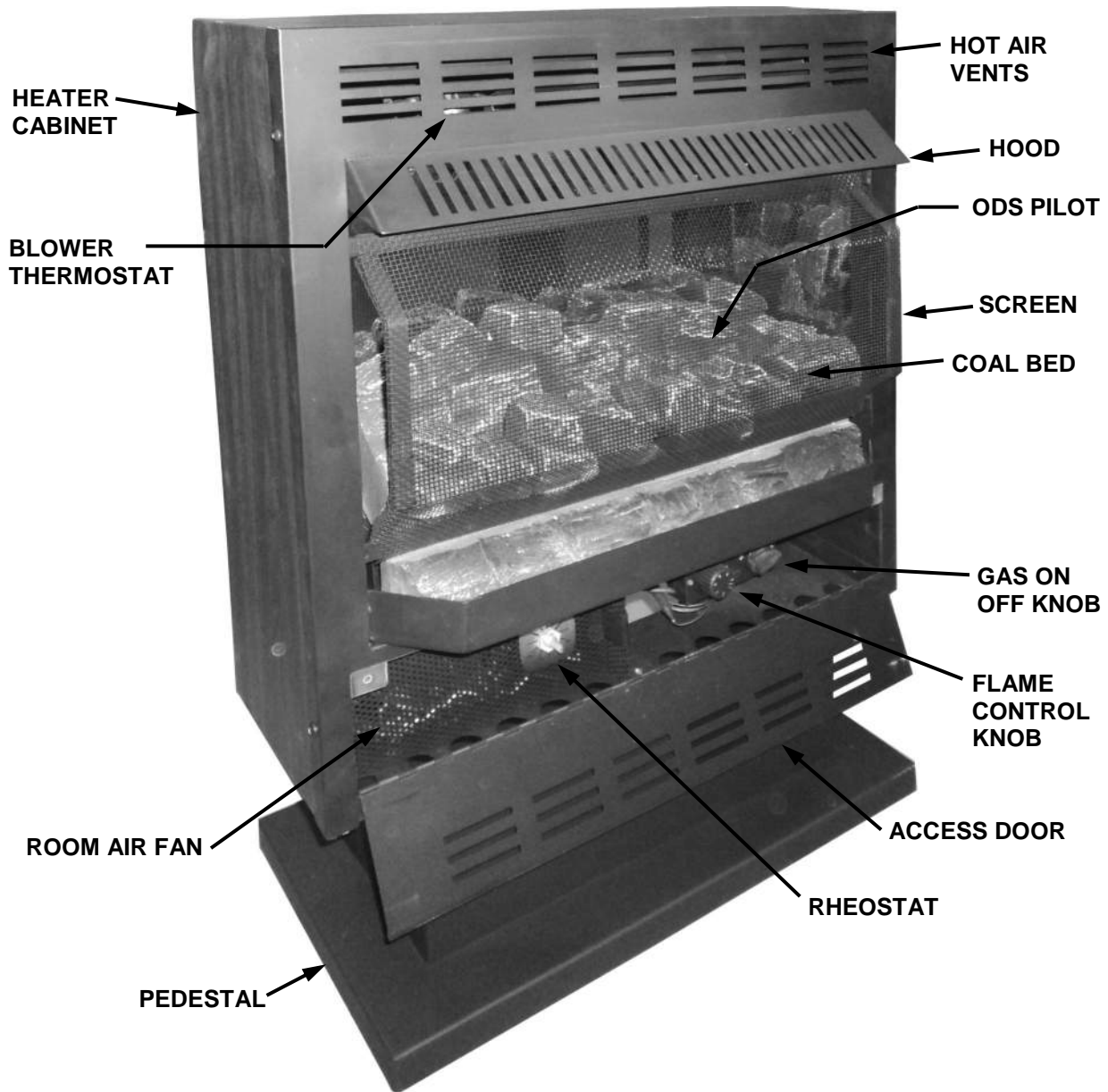

Figure 1

WARNING: Installation and repairs should be performed by a qualified service person. The appliance should be inspected before use and at least annually by a professional service person. More frequent cleaning may be required due to excessive lint from carpeting, bedding material, etc. It is imperative that control compartments, burners and circulating air passageways of appliance be kept clean.

PRODUCT FEATURES

SAFETY DEVICE

This heater has a pilot with an Oxygen Depletion Sensor Shutoff System (ODS). The ODS/pilot is a required feature for vent-free room heaters. The ODS/pilot shuts off heater if there is not enough (oxygen) fresh air.

PIEZO IGNITION SYSTEM

This heater has a piezo igniter. This system requires no matches, batteries or other sources to light the heater.

This appliance is only for use with type of gas indicated on rating plate. This appliance is not convertible for use with other gases.

Model 1130 CONTEMPORARY P* or N*- (Sensing or Modulating Bulb) - This heater has a thermostat sensing bulb. This bulb will modulate flame up and down on demand of heat desired.

*P - Propane or LP (Liquid Petroleum)

*N - Natural gas

UNPACKING

1. Remove all protective packaging applied to heater for shipment.
2. Check heater for any shipping damage. If heater is damaged, promptly inform dealer from whom you made purchase.
3. Lift heater by each bottom corner.

WARNING: Any change to this heater or its controls can be dangerous.

CAUTION

THIS HEATER CREATES WARM AIR CURRENTS. THESE CURRENTS MOVE HEAT TO WALL SURFACES NEXT TO HEATER. DO NOT INSTALL HEATER WHERE IMPURITIES IN AIR MAY EXIST.

MINIMUM CLEARANCES TO COMBUSTIBLE CONSTRUCTION

NOTE: FOR GARAGE INSTALLATION

- Heater Pilot and Burner must be at least **18"** off floor.
- Locate heater **AWAY FROM ANY MOVING VEHICLE.**
- **Keep appliance area clear and free from combustible materials, gasoline and other flammable vapors and liquids.**

For convenience and efficiency, install heater:

- * in easy access locations
- * in coolest part of room
- * near an electrical outlet

Minimum Clearances are as follows:

42" from top of appliance to ceiling. 5" from right front corner of appliance to an adjacent side wall, and 5" from left side of appliance to an adjacent side wall and 7" from bottom of appliance to top surface of carpeting, tile or other combustible materials in area described. See figure 2 below.

- **The installation must conform with local codes or in absence of local codes, with *National Fuel Gas Code, ANSI Z223.1/NFPA 54.***

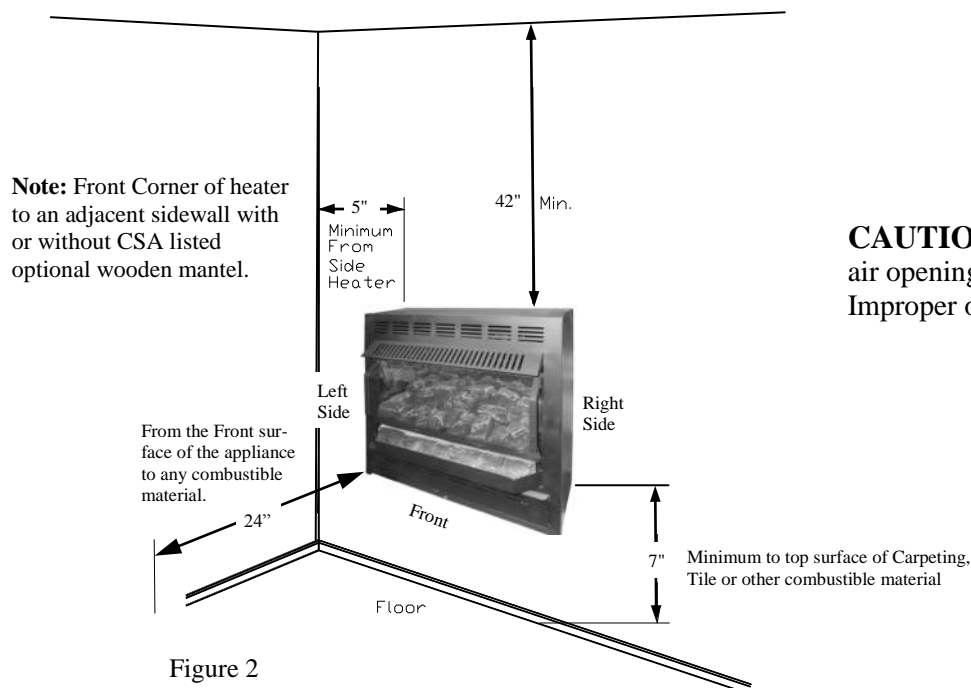

Figure 2

INSTALLATION

NOTE: This heater may be installed three different ways:

- 1. Wall Mounted**
- 2. Freestanding heater (with optional pedestal)**
- 3. Freestanding (with optional wooden mantel)**

WALL MOUNT INSTALLATION:

1. After determining location for heater, unfold template provided and place bottom of template a minimum of 7" from bottom of unit to floor.

NOTE: Be sure to level template before punching holes.

2. With template in place and four black dots centered on studs, punch the four centers marked in black dots with a sharp pointed object. Insert four wood screws provided with unit into four punched holes.

NOTE: Leave 5/8" of the screw projecting from finished wall.

Figure 3

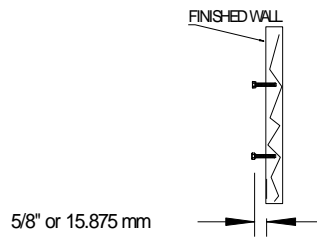

For sheet rock walls, use wing nuts or anchor wings. Remove wing nut from bolt. Place a nut and washer with same thread and size on bolt. Push wing nut through wall surface allowing wings to spread. Tighten nut that you placed on bolt, leaving required 5/8" between back of bolt head and finished wall.

Figure 4

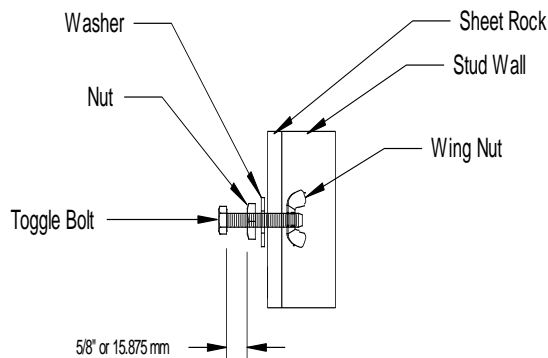

3. Lift heater by each bottom corner and place round part of tear drop punch out over each screw head. Gently push down until body of screw is at end of slot.

NOTE: Make sure unit is level.

4. Now you are ready to hook up gas line. The Model 1130 CONTEMPORARY allows for a rear or bottom connection for gas line. See “Gas Connection” on page 17 for details.

CLEANING INFORMATION:

Cleaning is a vital part of life of your stove. In order to properly clean unit, remove front. To remove: use Phillips screwdriver to loosen four screws at front sides. You will find that front is easily removed in one piece.

Next you must remove the logs from the burner base. Gently place your hands, one on each side of logs and lift upward. Do not apply too much force on the logs, this may cause damage to fiber material.

Figure 5

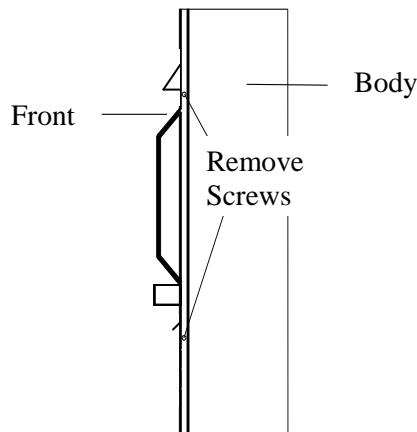

A vacuum cleaner works well for removal of dust and debris from around burner and logs. To remove burner, use a tool with an extension to loosen screw in base. The screw is located between log and actual base. Simply slide base out of unit. **NOTE:** Do not use a pin or any sharp object to clean the pilot.

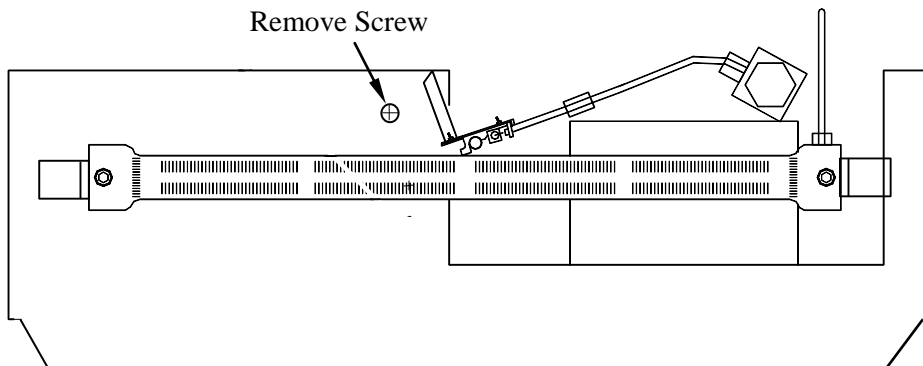

NOTE: Any parts that are removed while cleaning must be replaced before operating appliance.

Figure 6

FREESTANDING WITH OPTIONAL PEDESTAL INSTALLATION

1. Place heater on backside and center pedestal on bottom. Mark the 4 pre-punched holes in pedestal angle. Use the 4 self-tapping screws provided with pedestal to drill 4 marked spots. Secure pedestal to bottom of unit.

NOTE: If the gas line is run through floor, you may want to drill a hole in bottom of pedestal.

2. The pedestal must be secured to floor. One option is to drill holes in top side of bottom of pedestal. Use screws or “Ell” brackets to fasten pedestal to floor.

IMPORTANT: THE 1130 CONTEMPORARY FREESTANDING UNIT MUST BE INSTALLED ON A FLAT SURFACE (SUCH AS A WOOD PANEL, METAL OR HARDWOOD FLOORS.)



FREESTANDING OPTIONAL WOODEN MANTEL INSTALLATION

Use the two (2) metal mounting Z-Brackets provided to secure the 1130 CONTEMPORARY into wooden mantel, wood screws provided to secure brackets in place.

IMPORTANT! The Z-Brackets must be properly installed. Failure to install the Z-Brackets may cause property damage or personal injury.

Use the four (4) sheet metal screws provided to secure the mounting brackets to the rear of stove. Insert the screws into back of unit.

With brackets secured to unit. From rear, slide unit into opening of mantel, centering from left to right.

With four (4) wood screws provided secure brackets to rear of mantel. See Figure 7, page 12.

NOTE: Connect gas line and check for leaks before placing heater and mantel against wall.

See “Gas Connection” on page 17.

OPTION: Fasten wooden mantel to wall. Use “Ell” brackets at top or bottom corners.

MOUNTING BRACKET VIEW FREE-STANDING OPTIONAL DELUXE FINISHED MANTEL

NOTE: "MODEL 1130 CONTEMPORARY TO BE USED WITH NEW BUCK CORP. MANTEL ONLY, PART # PAKDM1127." IF USED WITH ANY OTHER MANTEL WARRANTY WILL BE VOID.

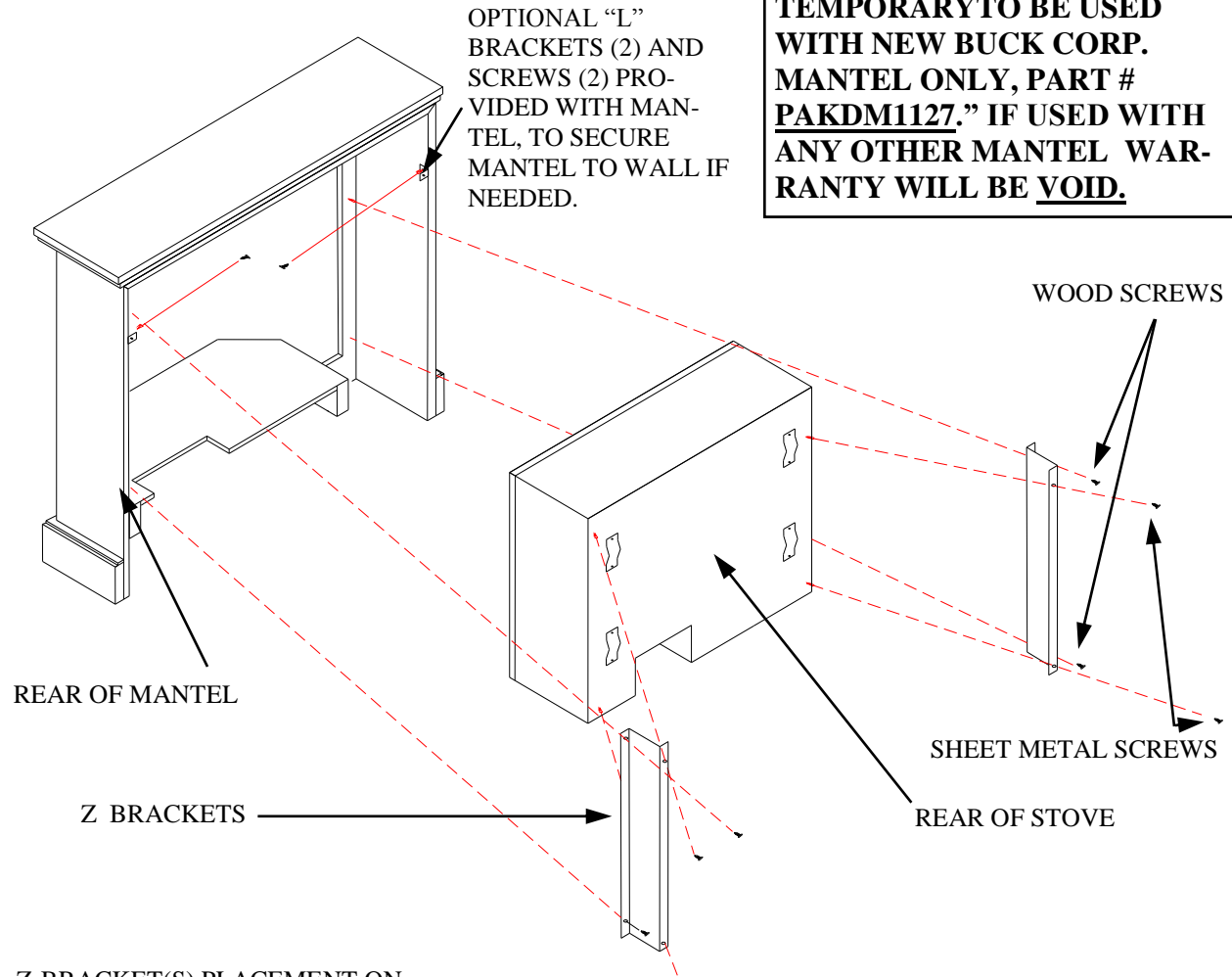

Z-BRACKET(S) PLACEMENT ON STOVE

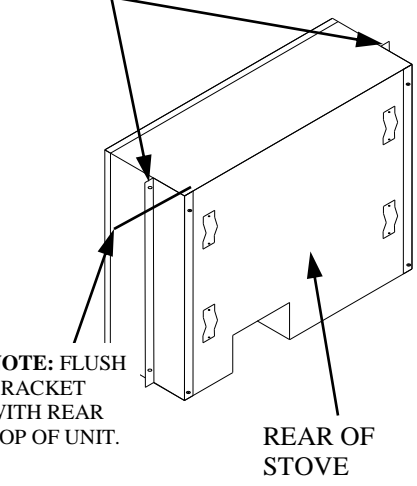

Z-BRACKETS MOUNTED (SCREWED) TO REAR OF STOVE AND SECURED (SCREWED) TO INSIDE REAR OF FRONT OF MANTEL.

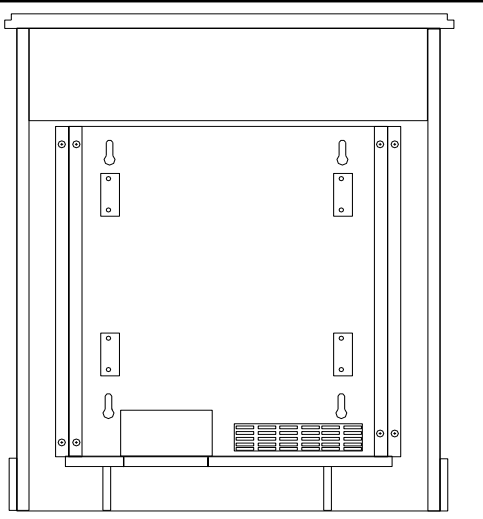

Figure 7

PRODUCING ADEQUATE AIR FOR COMBUSTION AND VENTILATION

This section is for residential or manufactured (mobile) installation

This heater shall not be installed unusually tight construction or unconfined space unless provisions are adequate for combustion and ventilation air.

NOTE: This heater shall not be installed in a room or space unless required volume of indoor combustion air is provided by method in *National Fuel Gas Code, ANSIZ223.1/NFPA 54, International Fuel Gas Code* or applicable codes.

The **National Fuel Gas Code, ANSI Z223.1/NFPA 54** defines unusually tight construction or unconfined space as a space whose volume is less than 50 cubic feet per per 1,000 BTU per hour (4.8m^3 per kw) of aggregate input rating of all appliances installed in that space and an unconfined space as a space whose volume is not less than 50 cubic feet per 1,000 BTU per hour (4.8m^3 per kw) of aggregate input rating of all appliances installed in that space. Rooms communicating directly with space in which appliances are installed, through openings not furnished with doors, are considered a part of unconfined space.

WARNING: IF AREA IN WHICH THE HEATER MAY BE OPERATED DOES NOT MEET REQUIRED VOLUME FOR INDOOR COMBUSTION AIR, COMBUSTION AND VENTILATION AIR SHALL BE PROVIDED BY ONE OF METHODS DESCRIBED IN NATIONAL FUEL GAS CODE, ANSI Z223.1/NFPA 54, THE INTERNATIONAL FUEL GAS CODE, OR APPLICABLE CODES.

WARNING: IF THE AREA IN WHICH HEATER MAY BE OPERATED IS SMALLER THAN THAT DEFINED AS AN UNCONFINED SPACE OR IF BUILDING IS OF UNUSUALLY TIGHT CONSTRUCTION, PROVIDE ADEQUATE AIR FOR COMBUSTION AND VENTILATION BY ONE OF METHODS DESCRIBED IN NATIONAL FUEL GAS CODE, ANSI Z223.1/NFPA 54 AIR FOR COMBUSTION AND VENTILATION OR APPLICABLE LOCAL CODES.

Unusually tight construction is defined as construction where:

- Walls and ceilings exposed to outside atmosphere have a continuous water vapor retarder with a rating of 1 perm (6×10^{-11} kg per pa-sec- m^2) or less with openings gasketed or sealed.
- Weather stripping has been added on openable windows and doors.
- Caulking or sealants are applied to areas such as joints around window and door frames, between sole plates and floors, between wall-ceiling joints, between wall panels, at penetrations for plumbing, electrical, and gas lines and at other openings.

NOTE: SOME AREAS IN THE UNITED STATES HAVE HIGHER REQUIREMENTS FOR CUBIC FEET PER 1000 BTU/ HOUR INPUT. (EX. CINCINNATI, OHIO CODES REQUIRE 70 CUBIC FEET). CHECK YOUR LOCAL CODE BEFORE INSTALLATION.

DETERMINING FRESH-AIR FLOW FOR HEATER LOCATION

DETERMINE IF YOU HAVE UNUSUALLY TIGHT CONSTRUCTION OR UNCONFINED SPACE

Use this worksheet to determine if you have confined or unconfined space.

SPACE: Includes room in which you will install heater plus adjoining rooms with doorless passageways or ventilation grills between the rooms.

1. **Determine the volume of the space (length x width x height).**

Length x Width x Height = _____ cu.ft.(volume of space)

EXAMPLE: 20 ft.(Length) x 16 ft.(Width) x 8 ft.(ceiling Height)=
2560 cu. ft. (volume of space)

If additional ventilation to adjoining room is supplied with grills or openings, add volume of these rooms to total volume of the space.

2. **Divide space volume by 50 cubic feet to determine the maximum BTU/Hr space can support.**

_____ (volume of space)/50 cu. ft. =maximum BTU/Hr the space can support)

EXAMPLE: 2560 cu. ft. (volume of space /50 cu. Ft .= 51.2 or
51200 (maximum BTU/Hr the space can support)

3. Add the BTU/Hr of all fuel burning appliances in space.

Vent-free heater	_____	BTU/Hr
Gas water heater*	_____	BTU/Hr
Gas furnace	_____	BTU/Hr
Vented gas heater	_____	BTU/Hr
Gas fireplace logs	_____	BTU/Hr
Other gas appliances*	+ _____	BTU/Hr
Total	= _____	BTU/Hr

Example: Gas water heater 40000 BTU/Hr
Vent-free heater + 18000 BTU/Hr
Total = 58000 BTU/Hr

*Does not include direct-vent gas appliances. Direct-vent draws combustion air from outdoors and vents to outdoors.

4. Compare the maximum BTU/Hr the space can support with actual amount of BTU/Hr used.

_____ BTU/Hr (maximum the space can support)
_____ BTU/Hr (actual amount of BTU/Hr used)

Example: 51200 BTU/Hr (maximum the space can support)
58000 BTU/Hr (actual amount of BTU/Hr used)

The space in above example is unusually tight construction because actual BTU/Hr used is more than maximum BTU/Hr space can support. You must provide additional fresh air. Your options are as follows: A. Rework worksheet, adding space of an adjoining room. If extra space provides an unconfined space, remove door to adjoining room or add ventilation grills between rooms. See “Ventilation Air For Combustion And Ventilation From Inside Building”, page 21.

B. Vent room directly to outdoors. See “Ventilation Air For Combustion And Ventilation From Outdoors”, page 22.

C. Install a lower BTU/Hr heater, if lower BTU/Hr size makes room unconfined.

If actual BTU/Hr used is less than maximum BTU/Hr space can support, space is an unconfined space. You will need no additional fresh air ventilation.

WARNING: YOU MUST PROVIDE ADDITIONAL AIR FOR COMBUSTION AND VENTILATION IN UNUSUALLY TIGHT CONSTRUCTION.

VENTILATION AIR FOR COMBUSTION AND VENTILATION FROM INSIDE BUILDING

This fresh air would come from an adjoining unconfined space. When venting to an adjoining space, you must provide two permanent openings: one within 12" of ceiling and one within 12" of floor on wall connecting two spaces (see Options 1 and 2, Figure 8). You can also remove door into adjoining room (see Option 3, in Figure 8).

WARNING

REWORK WORKSHEET, ADDING SPACE OF ADJOINING UNCONFINED SPACE. COMBINED SPACES MUST HAVE ADEQUATE AMOUNT OF AIR TO SUPPLY ALL APPLIANCES IN BOTH SPACES.

NOTE: Each opening shall have a minimum free area of 1 square inch per 1000 BTU's per hour of total input rating of all gas utilization equipment in confined space, but not less than 100 square inches.

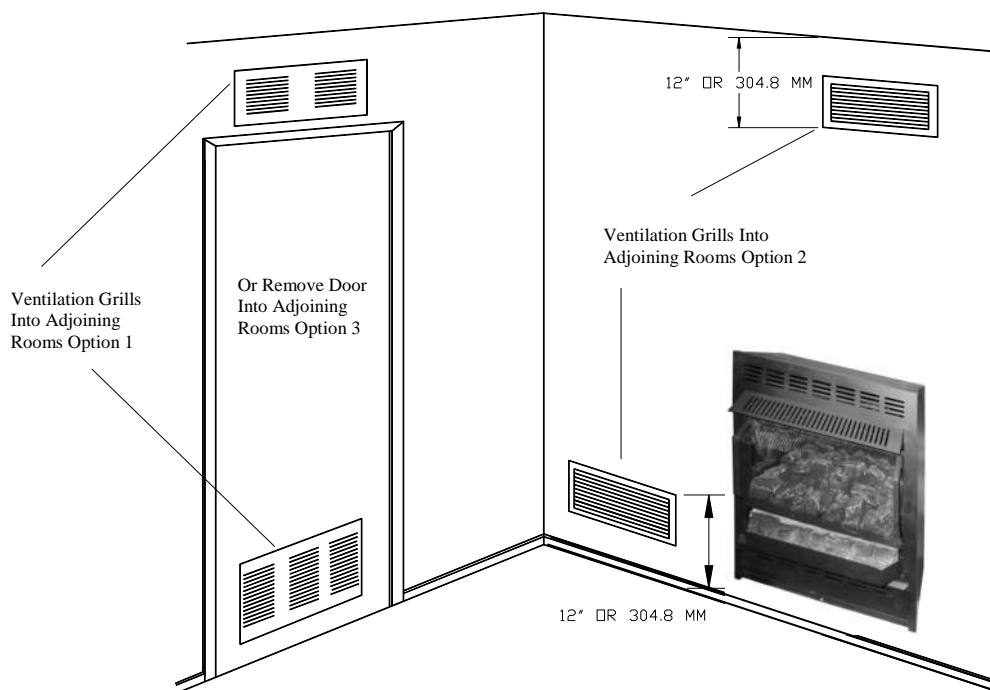

Figure 8

NOTE: This heater shall not be installed in a room or space unless required volume of indoor combustion air is provided by the method in *National Fuel Gas Code, ANSIZ223.1/NFPA 54, International Fuel Gas Code*, or applicable codes.

WARNING

THIS HEATER MUST HAVE ADEQUATE AMOUNT OF AIR FOR PROPER OPERATION. IF NOT, POOR FUEL COMBUSTION COULD RESULT. READ THE FOLLOWING INSTRUCTIONS TO ENSURE PROPER AMOUNT OF AIR FOR THIS AND OTHER FUEL-BURNING APPLIANCES IN YOUR HOME.

VENTILATION AIR FOR COMBUSTION AND VENTILATION FROM OUTDOORS

Provide extra fresh air by using ventilation grills or ducts. You must provide two permanent openings: one within 12" of ceiling and one within 12" of floor. Connect these items directly to outdoors. These spaces include attics and crawl spaces. Follow **National Fuel Gas Code NFPA 54/ANSI Z223.1**, Section 5.3, "Air For Combustion and Ventilation" for required size of ventilation grills or ducts.

IMPORTANT: Do not provide openings for inlet air into attic if attic has controll power vent.

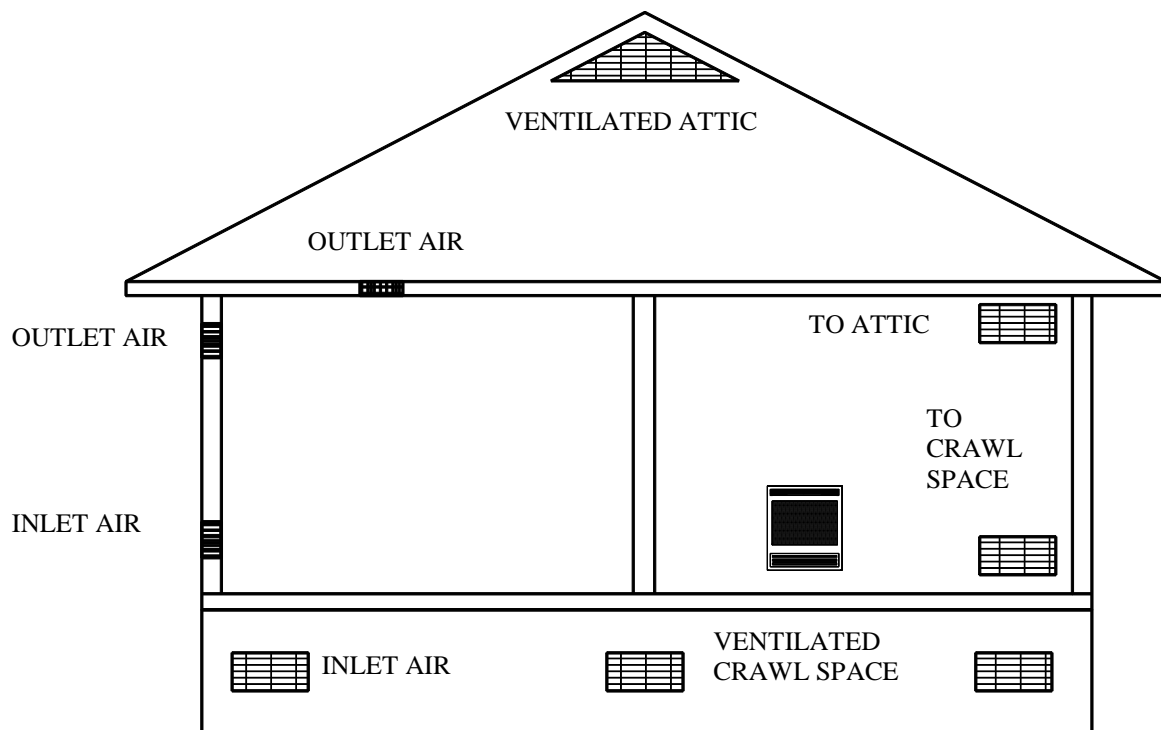

Figure 9

WARNING: ANY CHANGE TO THIS HEATER OR ITS CONTROLS CAN BE DANGEROUS.

GAS CONNECTION

Check gas type. Use only type of gas indicated on valve rating plate. If type of gas listed on plate is not your type of gas supply, **DO NOT INSTALL**. Contact your dealer for proper model. Always use an external regulator for all LP heaters to reduce supply tank pressure to a maximum of 13" W.C. This is in addition to regulator furnished with heater.

WARNING: CONNECTION DIRECTLY TO AN UNREGULATED LP TANK CAN CAUSE AN EXPLOSION.

The normal gas connection is 3/8" N.P.T. made at left side (facing the front of appliance) of appliance. If a right side connection is desired, connecting pipe may be led under rear of burner base to terminate at right side for connection to inlet of valve.

NOTE: The connecting pipe must be internally tinned copper tubing for use with natural gas. *Test for leaks using a solution of soap and water after completing connection. DO NOT USE OPEN FLAME.*

WARNING: Installation and repairs should be performed by a qualified service person. The appliance should be inspected before use and at least annually by a professional service person. More frequent cleaning may be required due to excessive lint from carpeting, bedding material, etc. It is imperative that control compartments, burners and circulating air passageways of appliance be kept clean.

CONNECTING TO A GAS SUPPLY

CAUTION: NEVER CONNECT HEATER DIRECTLY TO PROPANE SUPPLY. THIS HEATER REQUIRES AN EXTERNAL REGULATOR (NOT SUPPLIED). INSTALL EXTERNAL REGULATOR BETWEEN HEATER AND PROPANE SUPPLY.

The installer must supply external regulator for liquid propane gas. The external regulator will reduce incoming gas pressure. You must reduce incoming gas pressure to between 11" and 14" of water. If incoming gas pressure is not reduced, heater regulator damage will occur. Install external regulator with vent pointing down.

You must also install a sediment trap. Locate sediment trap where it is within reach for cleaning. A sediment trap filters moisture and contaminants. This also helps to keep heater controls clean. If sediment trap is missing or installed wrong, your unit will not run properly.

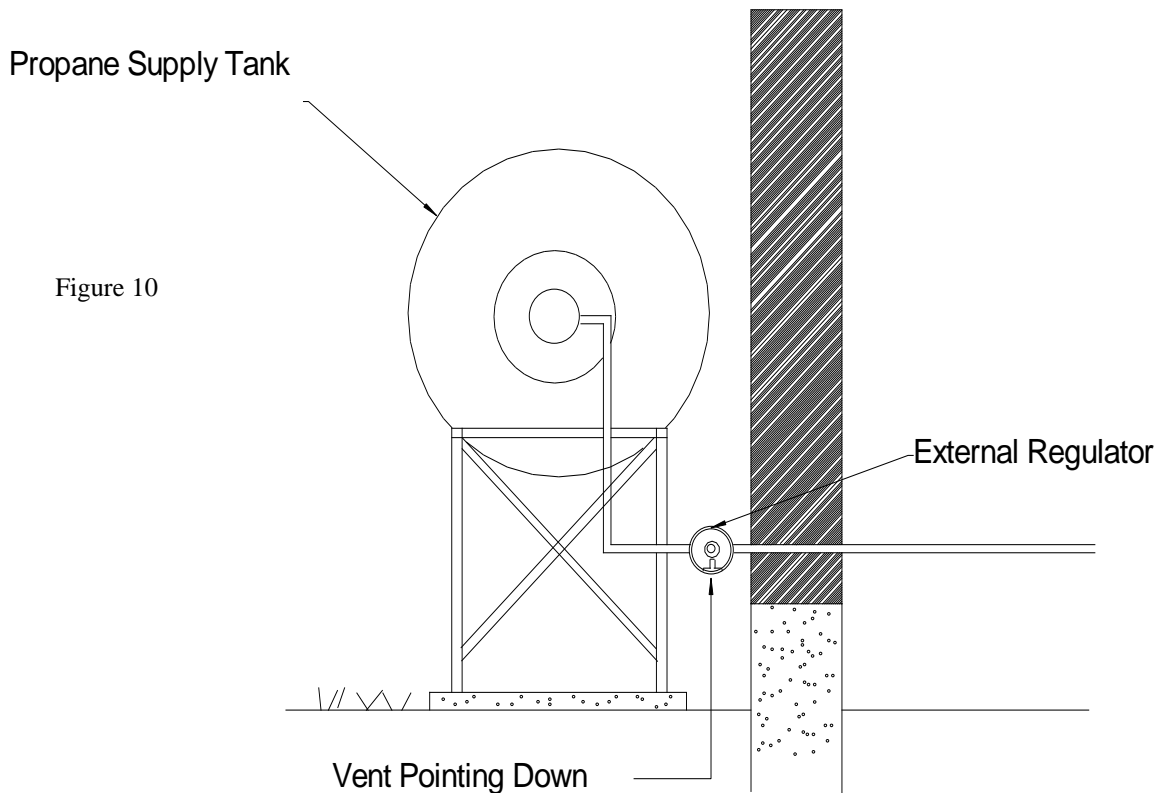

CAUTION: Use only new black iron or steel pipe. Internally tinned copper tubing may be used in certain areas. Check state and local codes. Use pipe of 1/2" or greater in diameter to allow proper gas volume. If piping is too small, undue loss of pressure will occur.

Installation must include manual shutoff valve and plugged 1/2" NPT tap. Locate NPT tap within reach for test gauge hook-up. NPT tap must be upstream from unit.

Apply pipe joint sealant lightly to male threads. This will prevent excess sealant from going into pipe. Excess sealant in pipe could result in clogged heater valves.

CAUTION: USE PIPE JOINT SEALANT THAT IS RESISTANT TO LIQUID PETROLEUM (LP) GAS.

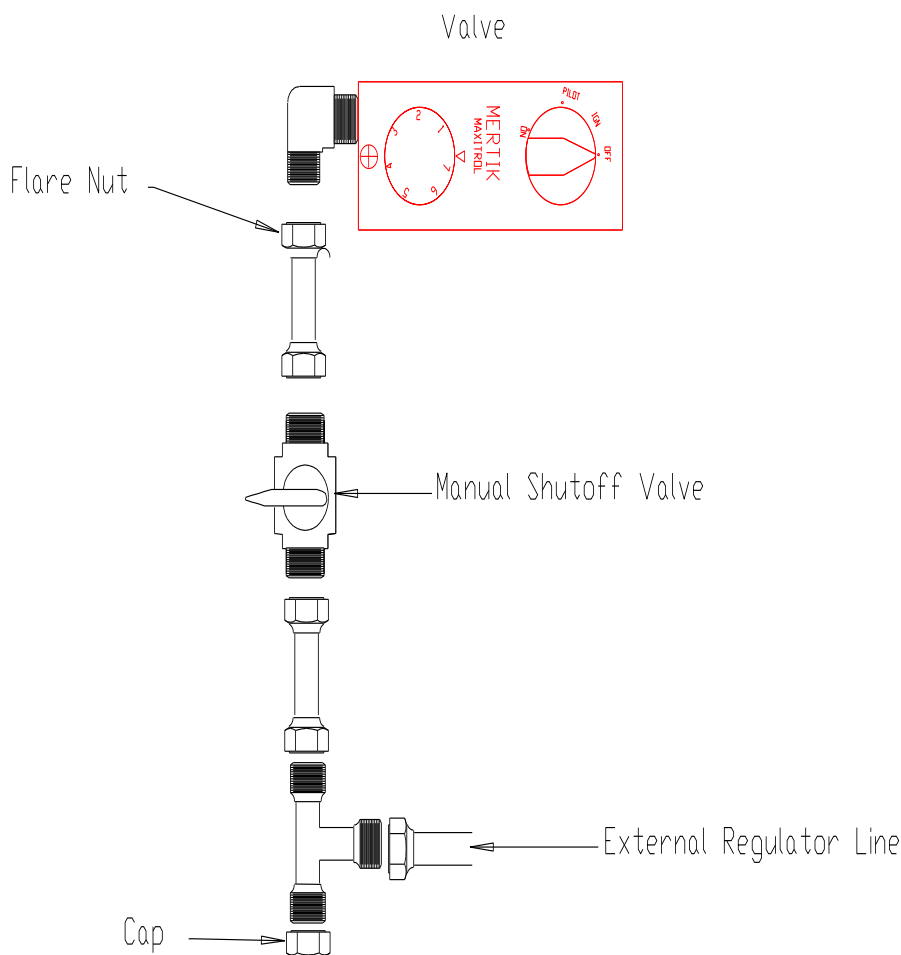

Figure 11

GAS PRESSURE CHECK

Check inlet pressure to the burner to insure that it is as shown in table below.

NOTE: The pressure check point is located on right side of valve facing burner.

The appliance and its appliance main gas valve must be disconnected from gas supply piping system during any pressure testing of that system at test pressures in excess of 1/2 psi (3.5kPa).

The appliance must be isolated from gas supply piping system by closing its equipment shut-off valve during any pressure testing of gas supply piping system at test pressures equal to or less than 1/2 psi (3.5 kPa).

MODEL	FP-BR10-ZC	FP-BR10-ZC
Gas	Natural	Propane
Maximum Heat Input	10000	10000
Gas Inlet Pressure:		
Maximum	10.5 ins. W.C.	13 ins. W.C.
Minimum	* 5 ins. W.C.	*11 ins. W.C.
Manifold Pressure	3.5 ins. W.C.	9 ins. W.C.

NOTE: On initial installation it may be necessary to bleed out air in gas lines. Do this by holding control knob and turning knob to pilot position for about 30 seconds.

To check Regulator pressure, remove pressure tag plug at left side of Regulator facing heater. The pressure should be checked with heater burning and control set on high. After measuring pressure, replace pressure tap plug, ensuring that there are no leaks.

* For purpose of minimum input adjustment.

WARNING

**This appliance is equipped for (natural or propane) gas.
Field conversion is not permitted.**

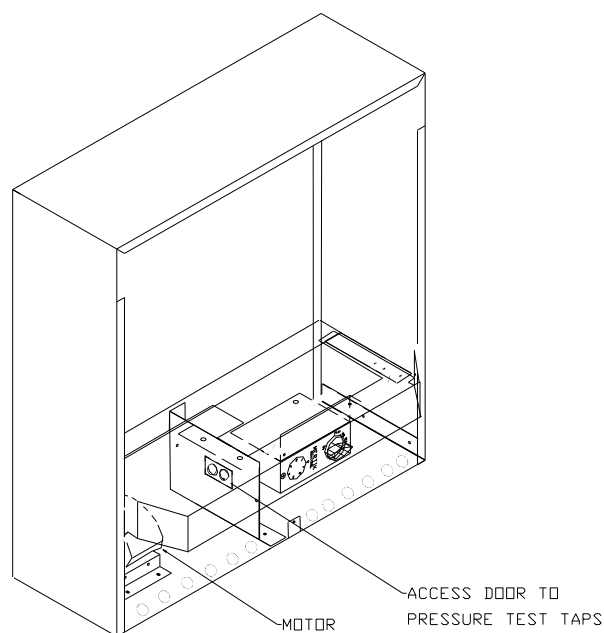

Figure 12

COAL BED PLACEMENT FOR 1130

Coal Bed is shipped secured in unit.

NOTE: When operated for first time, Coal Bed may emit a “paper burning” smell. This smell will gradually diminish and will be totally eliminated after first few hours of operation. Do not use blower at this time.

Front View of Coal Bed

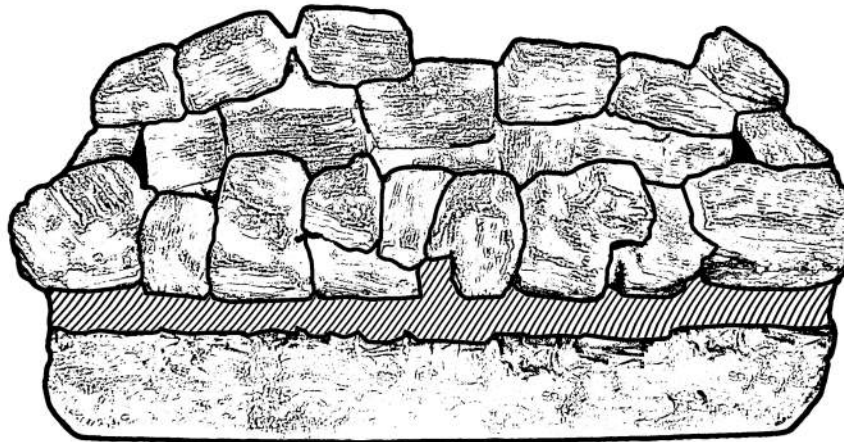

WARNING

FAILURE TO POSITION PARTS IN ACCORDANCE WITH THESE DIAGRAMS OR FAILURE TO USE ONLY PARTS SPECIFICALLY APPROVED WITH HEATER MAY RESULT IN PROPERTY DAMAGE OR PERSONAL INJURY.

WARNING

DO NOT ALLOW FANS TO BLOW DIRECTLY INTO FIREPLACE. AVOID ANY DRAFTS THAT ALTER BURNER FLAME PATTERN.

OPERATING INSTRUCTIONS

Before operating this appliance, proceed through following checklist.

1. Read and understand these instructions before operating this appliance.
2. Check that there no leaks. If you smell gas do not attempt to light this appliance.

LIGHTING INSTRUCTIONS MODULATING VALVE(MAXITROL) FOR YOUR SAFETY, READ BEFORE LIGHTING

WARNING

IF YOU DO NOT FOLLOW THESE INSTRUCTIONS EXACTLY, A FIRE OR EXPLOSION MAY RESULT CAUSING PROPERTY DAMAGE, PERSONAL INJURY OR LOSS OF LIFE.

- A. This appliance has a pilot which must be lit by hand. When lighting pilot, follow these instructions exactly.
- B. **BEFORE LIGHTING:** Smell all around appliance for gas. Be sure to smell next to floor because gas is heavier than air and will settle on floor.

WHAT TO DO IF YOU SMELL GAS

- * Do not try to light any appliance.
 - * Do not touch any electrical switch; do not use any phone in your building.
 - * Immediately call your gas supplier from a neighbor's phone. Follow gas supplier's instructions.
 - * If you cannot reach your gas supplier, call your local fire department.
- C. Use only your hand to push in or turn gas control knob. Never use tools. If knob will not push in or turn by hand, don't try to repair it, call a qualified service technician. Force or attempted repair may result in fire or explosion.
 - D. Do not use this appliance if any part has been under water. Immediately call a qualified service technician to inspect appliance and to replace any part of control system and any gas control which has been under water.

LIGHTING INSTRUCTIONS

1. STOP! Read the safety information on previous page.
2. Make sure manual shutoff valve is fully **closed**.
3. Open access panel door, located in lower front center of base for access to control knobs.
4. Turn off all electric power to appliance.
5. Set thermostat (flame control) to lowest setting.
6. Push in and turn control knob clockwise  to “OFF” position.

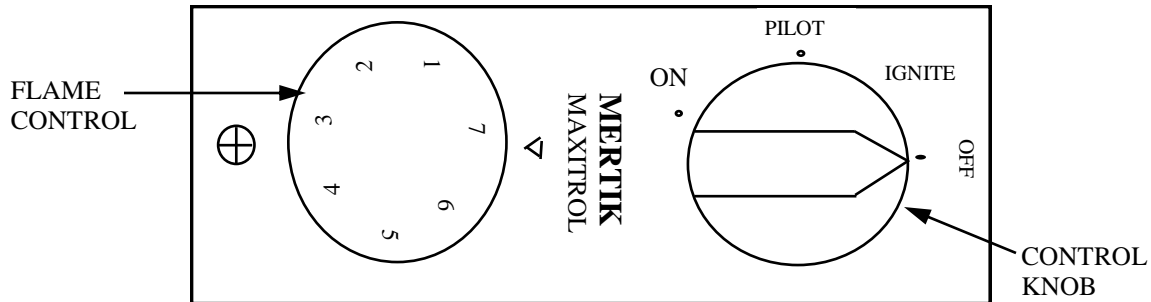
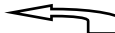



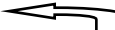
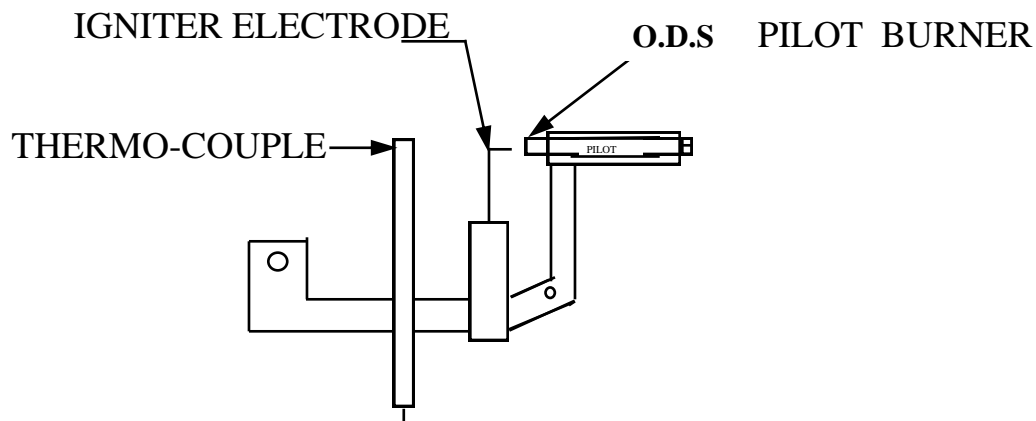

FIGURE 3

7. Wait (5) five minutes to clear out any gas. Then smell for gas, including near floor. If you smell gas, STOP! Follow step “B” in safety information on previous page. If you don’t smell gas, go to next step.
8. Find Pilot: follow small metal tub from right hand rear of gas control valve. The pilot is located behind burner tub and in front of rear log. Fully **open** the manual shut-off valve.
9. Turn control knob counterclockwise  to “PILOT” position. Press in control knob for (15) fifteen seconds (see figure 3).
10. With control knob pressed in, turn control knob clockwise  to **IGNITE** and then **immediately back** to **PILOT** with button still pressed in. This will light pilot. If needed, keep repeating this step until pilot lights.
11. Keep control knob pressed in for one (1) minute after lighting pilot. After (1) minute, release control knob. If pilot goes out, repeat steps 1 through 9.
 - If the knob does not pop out when released, stop and immediately call your service technician or gas supplier.
 - If pilot will not stay lit after several tries, turn gas control knob to “OFF” and call your service technician or gas supplier.
12. Turn control knob counterclockwise  to “ON” position.
13. Set thermostat (flame control) to desired setting. Turn clockwise  for “LOW” and counterclockwise  for “HIGH”.



14. Close access panel door.
15. Turn on all electric power to appliance.

CAUTION

DO NOT TRY TO ADJUST HEATING LEVELS BY USING MANUAL SHUTOFF VALVE.

TO TURN OFF GAS TO APPLIANCE

SHUTTING OFF UNIT:

1. Open access panel door, located in lower front center of base for access to control knobs.
2. Set thermostat (flame control) to lowest setting.
3. Turn control knob clockwise to full **“OFF”** position.
4. Turn off all electrical power to appliance if service is to be performed.
5. Close access panel door.

SHUTTING OFF BURNER ONLY (pilot stays lit)

1. Open access panel door, located in lower front center of base for access to control knobs.
2. Turn control knob clockwise to **“PILOT”** position.
3. Close access panel door.

CAUTION: Hot while in operation. Do Not Touch. Keep children, clothing, furniture, gasoline, and other liquids having flammable vapors away.

CAUTION: DO NOT TRY TO ADJUST HEATING LEVELS BY USING MANUAL SHUTOFF VALVE.

WARNING: Improper installation, adjustment, alteration, service or maintenance can cause property damage, personal injury or loss of life. Refer to owner’s information manual provided with this appliance. Installation and service must be performed by a qualified installer, service agency or the gas supplier.





IMPORTANT: Always operate appliance at completely **“ON”** or completely **“OFF”** positions. Never use heater at a setting between these positions as this can result in improper combustion and excessive carbon monoxide emissions.

THERMOSTAT CONTROL OPERATION

The thermostat control used on this heater differs from standard thermostats. Standard thermostats simply turn burner on and off. The thermostat used on this heater senses room temperature and adjusts amount of gas flow to burner. This will increase or decrease the flame height. At times, room may exceed set temperature, which will cause burner to shut off. When room temperature drops below thermostat setting, burner will cycle itself on again. The flame control knob can be set to any level between 2 and 7.

NOTE: The thermostat sensing bulb measures the temperature of air near heater cabinet. This may not always agree with room temperature (depending on housing construction, installation location , room size, open air temperature etc.). Frequent use of your heater will allow you to determine your personal comfort levels.

MANUAL LIGHTING PROCEDURE

1. If the pilot cannot be ignited with the igniter on the control valve, it can be manually lit with use of a paper match and a lighter rod.
2. Place the match in holder and light. With other hand, depress control knob counterclockwise  to PILOT.
3. Use rod to light match and ignite pilot. The pilot is located behind burner tube and in front of rear log. Fully **open** manual shut-off valve.
4. Continue to hold control knob for an additional (1) one minute to ensure pilot is completely on.
 - If the knob does not pop out when released, stop and immediately call your service technician or gas supplier.
 - If pilot will not stay lit after several tries, turn gas control knob to “OFF” and call your service technician or gas supplier.
5. Turn control knob counterclockwise  to “ON” position.
-Set thermostat (flame control) to desired setting. Turn clockwise  for “LOW” and counterclockwise  for “HIGH”.
6. Close the access panel door.
7. Turn on all electric power to appliance.

FLAME CHECK

A periodic check of flames should be made. The pilot flame should always be present when unit is in operation. See Figure 17.

FLAME: Propane (LP) should produce a flame that is about 6" above rear of Coal Bed. This flame should be yellow.

Natural gas should produce a flame that is about 3" to 4" above rear of Coal Bed. This flame should be mostly blue except for top tips which should be yellow.

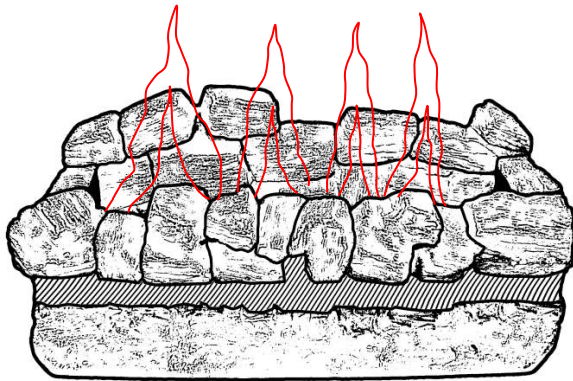

BURNER

NATURAL PILOT

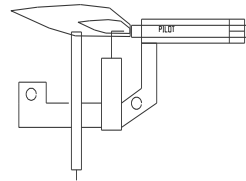

PROPANE PILOT

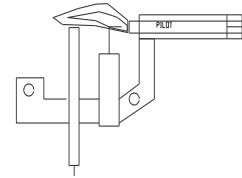
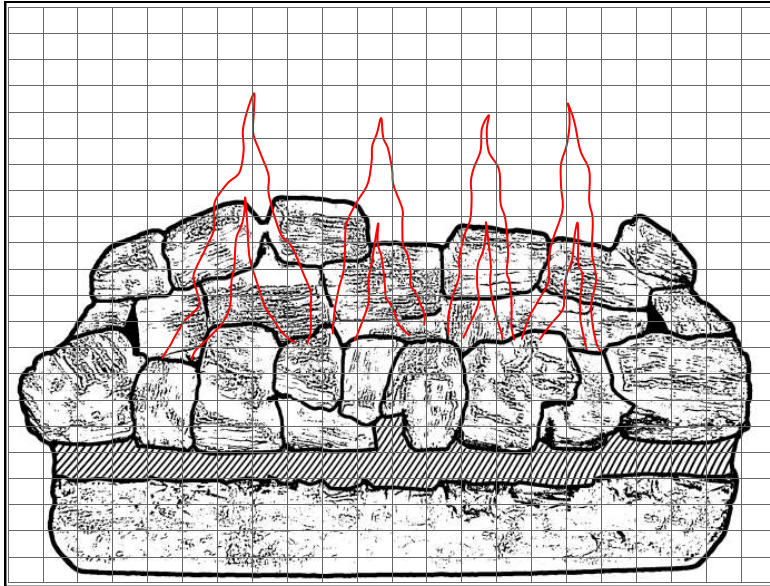

Figure 17

BURNER FLAME PATTERN

Figure 18 shows a correct burner flame pattern. Figure 19 shows an incorrect burner flame pattern.

NOTE: When using heater first time, Coal Bed will emit a paper like odor for about one hour.



CORRECT FLAME PATTERN AT HIGH POSITION

Figure 18 - Correct Burner Flame pattern

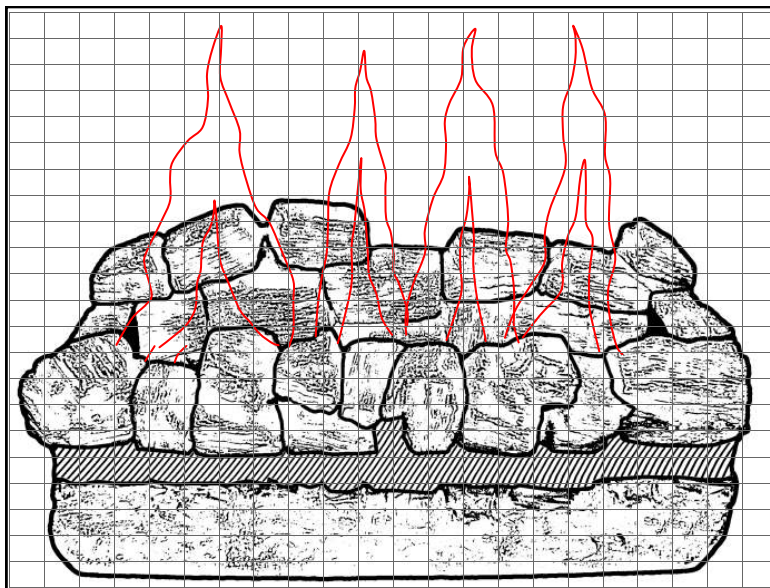

INCORRECT FLAME PATTERN AT HIGH POSITION

Figure 19 - Incorrect Burner Flame pattern

If burner flame pattern is incorrect, as shown in Figure 19:

*turn heater OFF (see “To Turn Off Gas to Appliance”, page 28.

*see “Troubleshooting”, pages 35 through 39.

WARNING: CHILDREN AND ADULTS SHOULD BE ALERTED TO HAZARDS OF HIGH SURFACE TEMPERATURE AND SHOULD STAY AWAY TO AVOID BURNS OR CLOTHING IGNITION. YOUNG CHILDREN SHOULD BE CAREFULLY SUPERVISED WHEN THEY ARE IN SAME ROOM WITH APPLIANCE.

WARNING: DO NOT PLACE CLOTHING OR OTHER FLAMMABLE MATERIALS ON OR NEAR APPLIANCE.

WIRING DIAGRAM

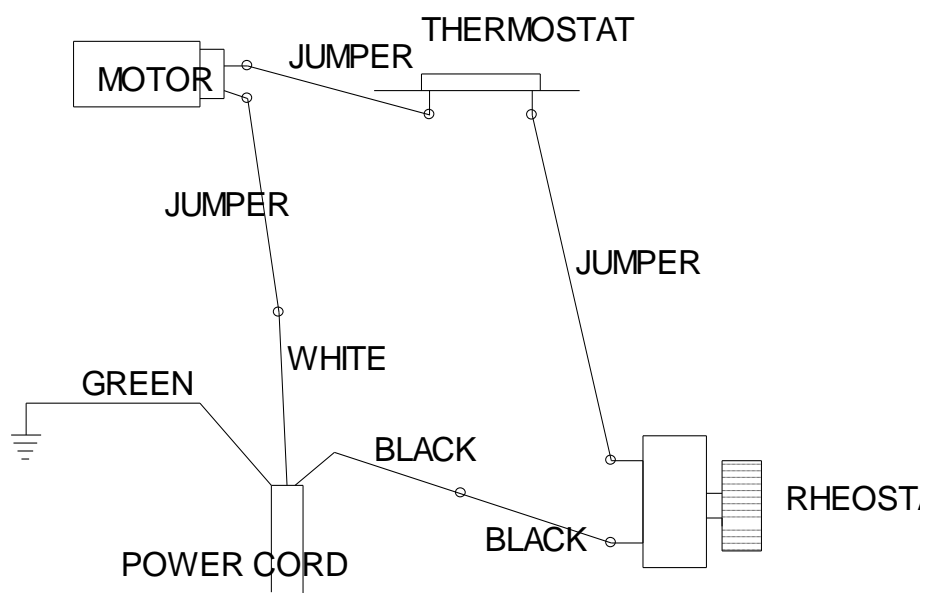

Figure 10

NOTE: If any of original wire as supplied with appliance must be replaced, it must be replaced with a wire of at least a 105° C. temperature rating.

NOTE: Installation and repair should be done by a qualified service person. This heater should be inspected before use and at least annually by a qualified service person. More frequent cleaning may be required due to excessive lint from carpeting, bedding material, etc. It is imperative that control compartments and circulating air passageways of heater be kept clean.

CAUTION: Label all wires prior to disconnection when servicing controls. Wiring errors can cause improper and dangerous operation.

Verify proper operation after servicing.

WARNING: ELECTRICAL GROUNDING INSTRUCTION: THIS APPLIANCE IS EQUIPPED WITH A THREE-PRONG (GROUNDING) PLUG FOR YOUR PROTECTION AGAINST SHOCK HAZARD AND SHOULD BE PLUGGED DIRECTLY INTO A PROPERLY GROUNDED THREE-PRONG RECEPTACLE.

NOTE: #PE A24001 Blower Motor
Rating: 120 volts/60MZ/0.54 Amps. 1 P.H.

Blower Motor is standard on all Model 1130 CONTEMPORARY. See page 38 for blower motor location.

NOTE: For convenience, allow licensed electrician to properly install a grounded 3-plug receptacle near unit.

SERVICING

Repair and replacement work should only be performed by a qualified service technician.

Always shut off gas supply and make sure heater is cool before beginning any service operation. Check for gas leaks after servicing.

REPAIR PARTS

A parts list with exploded view follows. Always include correct name, part number and model number of the heater when ordering service parts. Please contact your local dealer or distributor when ordering. If one is not available, you may contact:

New Buck Corporation
200 Ethan Allan Dr.
Spruce Pine, NC 28777
828-765-6144

IMPORTANT SAFEGUARDS

Although your gas logs are very realistic in appearance, it is not a real burning fireplace and must not be used for burning rejected material.

- To avoid irreparable damage to heater or personal injury, matches, paper, garbage or any other material **must not** be placed or thrown on top of logs or into flames.
- To avoid personal injury, do not touch hot surfaces when heater is operating.
- Close supervision is necessary when heater is being operated near children.

WARNING: THE COAL BED ARE MANUFACTURED FROM BONDED CERAMIC FIBER. THIS IS A COMMONLY USED MATERIAL IN INDUSTRY WORLDWIDE. IN EVENT THAT COAL BED SHOULD BE REMOVED, CARE SHOULD BE TAKEN NOT TO DAMAGE BONDED MATERIAL. INTENTIONAL MISUSE OR DELIBERATELY FRAGMENTING MATERIAL COULD LEAD TO INHALING FIBERS AND BE HAZARDOUS TO YOUR HEALTH.

THIS HEATER IS INTENDED FOR USE AS A GAS HEATER FIREPLACE AS DESCRIBED IN THESE INSTRUCTIONS. IT SHOULD NOT BE USED FOR ANY OTHER PURPOSE.

CLEANING

CAUTION: BEFORE CLEANING OR MOVING THESE LOGS OR OTHER PARTS OF HEATER, BE SURE TO READ ABOVE SECTIONS ON “IMPORTANT SAFEGUARDS.”

See Page 10, figure 6 before cleaning. The appliance must be turned “OFF” before cleaning inside firebox (burn area), make sure pilot is “OFF” and appliance has cooled.

- All cleaning should be carried out when heater is cold. Limited cleaning is required with normal use. Dusting front of base, top of piezo cover, or control knob panel may be required occasionally. Do not use cleaning fluids to clean logs or any other part of heater.
- If flames show unusual shapes or behavior, or if burner fails to ignite properly, burner holes may require cleaning. If this occurs, contact your nearest dealer to service heater.
- The heater can be cleaned by removing logs. Lift logs gently, as not to damage fiber pieces. use caution when removing. Lift each log by holding it carefully at each end. Use a vacuum cleaner to remove dust and loose particles from the base, logs and around the burner and ODS/Pilot. Gloves are recommended to prevent fibers from breaking the skin. If skin is broken, clean with soap and water.

WARNING: Failure to keep the primary air openings of the burner clean may result in soot and property damage.

TROUBLE-SHOOTING

WARNING

TURN OFF AND UNPLUG HEATER AND LET COOL BEFORE SERVICING. ONLY A QUALIFIED SERVICE PERSON SHOULD SERVICE AND REPAIR HEATER.

CAUTION

NEVER USE A WIRE, NEEDLE, OR SIMILAR OBJECT TO CLEAN ODS/PILOT. THIS CAN DAMAGE ODS/PILOT.

WARNING: Installation and repairs should be performed by a qualified service person. The appliance should be inspected before use and at least annually by a professional service person. More frequent cleaning may be required due to excessive lint from carpeting, bedding material, etc. It is imperative that control compartments, burners and circulating air passageways of appliance be kept clean.

See pages 32 through 35 for Trouble Shooting.

OBSERVED PROBLEM	POSSIBLE CAUSE	SOLUTION
1. Igniter button is pressed. No spark at ODS/Pilot	1. Igniter electrode positioned incorrectly 2. Igniter electrode broken 3. Igniter electrode not connected to igniter cable 4. Igniter cable pinched or wet 5. Piezo igniter nut is loose 6. Broken igniter cable 7. Bad piezo igniter	1. Replace igniter 2. Replace igniter 3. Reconnect igniter cable 4. Free igniter cable if pinched by any metal or tubing. Keep igniter cable dry 5. Tighten nut holding piezo igniter to heater cabinet. Nut is located inside heater cabinet at top 6. Replace igniter cable 7. Replace piezo igniter
2. Igniter button is pressed Spark at ODS/Pilot No Ignition	1. Gas supply turned off or manual shutoff valve is closed 2. Control knob not in "PILOT" position 3. Control knob not pressed in while in "PILOT" position 4. Air in gas lines when installed 5. Depleted gas supply 6. ODS/Pilot is clogged 7. Gas regulator setting is not correct	1. Turn on gas supply or open manual shutoff valve 2. Turn control knob to "PILOT" position 3. Press in control knob while in "PILOT" position. 4. Continue to hold down control knob. Repeat igniting operation until air is removed. 5. Contact local propane gas company 6. Clean ODS/Pilot or replace ODS/Pilot assembly 7. Replace gas regulator

OBSERVED PROBLEM	POSSIBLE PROBLEM	SOLUTION
3. ODS/PILOT lights but flame goes out when control knob is released	1. Control knob is not fully pressed in 2. Control knob not pressed in long enough 3. Safety interlock system has been triggered (if equipped) 4. Manual shutoff valve not fully open 5. Thermocouple connection loose at control valve. 6. Pilot flame not touching thermocouple, which allows thermocouple to cool, causing pilot flame to go out. This problem can be caused by one or both of the following: A) low gas pressure B) dirty or partially clogged ODS/Pilot 7. Control valve damaged	1. Press control knob completely 2. After ODS/Pilot lights keep control knob pressed 30 seconds 3. Wait 1 minute for safety interlock system to reset. 4. Fully open manual shutoff valve 5. Hand tighten until snug, then tighten 1/4 turn 6. A) Contact local propane gas company B) Clean ODS/Pilot (See “Cleaning and Maintenance”), or replace ODS/Pilot assembly 7. Replace valve control
4. Burner does not light after ODS/Pilot is lit	1. Burner orifice is clogged 2. Inlet gas pressure is too low	1. Clean burner (see “Cleaning and Maintenance”) or replace burner orifice 2. Contact local propane gas company

OBSERVED PROBLEM	POSSIBLE CAUSE	SOLUTION
5. Delayed ignition of burner	1. Manifold pressure is too low 2. Burner orifice is clogged	1. Contact local propane gas company 2. Clean burner (see “Cleaning and Maintenance”) or replace burner orifice
6. Burner backfiring during combustion	1. Burner orifice is clogged or damaged 2. Burner damaged 3. Gas regulator defective	1. Clean burner (see “Cleaning and Maintenance”) or replace burner orifice 2. Replace burner 3. Replace gas regulator
7. Slight smoke or odor during initial operation	1. Residues from manufacturing process	1. Problem will stop after a few hours of operation
8. Heater produces a whistling noise when burner is lit	1. Turning control knob to “HI” position when burner is cold (if equipped with this type of valve) 2. Air in gas line 3. Air passageways on heater blocked 4. Dirty or partially clogged burner orifice	1. Turn control knob to “LOW” position and allow to warm 2. Operate burner until air is removed from line. Call local propane company to check gas line 3. Observe minimum installation clearances 4. Clean burner or replace orifice

WARNING

IF YOU SMELL GAS:

- * **SHUT OFF GAS SUPPLY**
- * **DO NOT TRY TO LIGHT APPLIANCE**
- * **DO NOT TOUCH ANY ELECTRICAL SWITCH; DO NOT USE ANY PHONE IN YOUR BUILDING**
- * **IMMEDIATELY CALL YOUR GAS SUPPLIER FROM A NEIGHBOR'S PHONE. FOLLOW THE GAS SUPPLIER'S INSTRUCTIONS.**
- * **IF YOU CANNOT REACH YOUR GAS SUPPLIER, CALL THE FIRE DEPARTMENT.**

IMPORTANT: Operating heater where impurities in the air exist may create odors. Cleaning supplies, paint, paint remover, cigarette smoke, cements and glues, new carpet or textiles, etc. create fumes. These fumes may mix with combustion air and create odor.

OBSERVED PROBLEM	POSSIBLE CAUSE	SOLUTION
1. Heater produces a clinking/ticking noise just after burner is lit or shut off	1. Metal expands while heating or contracts while cooling	1. This is common with most heaters. If noise is excessive, contact a qualified service person.
2. Heater produces unwanted odors	1. Heater burning vapors from paint, hairspray, glues, etc (See Important above) 2. Low fuel supply 3. Gas leak (See WARNING above)	1. Ventilate room. Stop using odor causing products while heater is running. 2. Refill supply tank 3. Locate and control all leaks. See "Checking Gas Connections"
3. Heater shuts off in use (ODS operates)	1. Not enough fresh air is available. 2. Low line pressure 3. ODS/Pilot is partially clogged	1. Open window/door for ventilation 2. Contact local propane co. 3. Clean ODS/Pilot
4. Gas odor even when control knob is in "OFF" position	1. Gas leak (See WARNING , above). 2. Control valve defect	1. Locate and correct all leaks (see Checking Gas Connections) 2. Replace control valve
5. Gas odor during combustion	1. Foreign matter between control valve and burner 2. Gas leak (See WARNING above).	1. Remove foreign matter from gas tubing 2. Locate and correct all leaks (see "Checking Gas Connections")

TECHNICAL SERVICE

MODEL 1130 CONTEMPORARY - MODULATING VALVE

BTU(Variable)	11000/27000	11000/27000
Type Gas	Propane (LP)	Natural
Ignition	Piezo	
Pressure Regulator Setting	9" W.C.	3.5" W.C.
Inlet Gas Pressure (in. of water)*		
Maximum	14"	10.5" W.C.
Minimum	11"	5.0" W.C.
Dimensions, Inches (HxWxD)		
Heater	22" x 20 - 1/8" x 7"	
Weight (pounds)		
Heater	45 pounds	
Shipping		

* For purposes of input adjustment

PARTS LIST

KEY NO.	PART NUMBER	DESCRIPTION	QUANTITY
1	PO PNPSNH50JT	FRONT	1
2	MA1130BA-MAX-L (LP)	BURNER BASE	<u>OPTIONAL</u> 1
	MA1130BA-MAX-L (NAT)	BURNER BASE	<u>OPTIONAL</u> 1
3	PO1130COAL	COAL BED	1
4	MA1130	INNER SHIELD CHROME	1
5	A2-40-01	FAN MOTOR	1
6	PS 112724	MOTOR BRACE	1
7	PS 112740	SCREEN MOTOR COVER	1
8	PE KB9724	FAN SPEED CONTROL LABEL	1
9	PE BC204	RHEOSTAT	1
10	PE BC204A	RHEOSTAT KNOB	1
11	PE 400132	110 DEG. DISC THERMOSTAT	1
12	PE 30JUMPER	THERMO JUMPER WIRE	2
13	PE 400320	STRAIN RELIEF	1
14	PE 400240	POWER CORD	1
15	PH838TRHDBL	PHIL TRUSS SHEET METAL SCREW # 8 X 3/8	5

BLOWN UP VIEW OF HEATER, FAN MOTOR AND ALL REMOVABLE PARTS

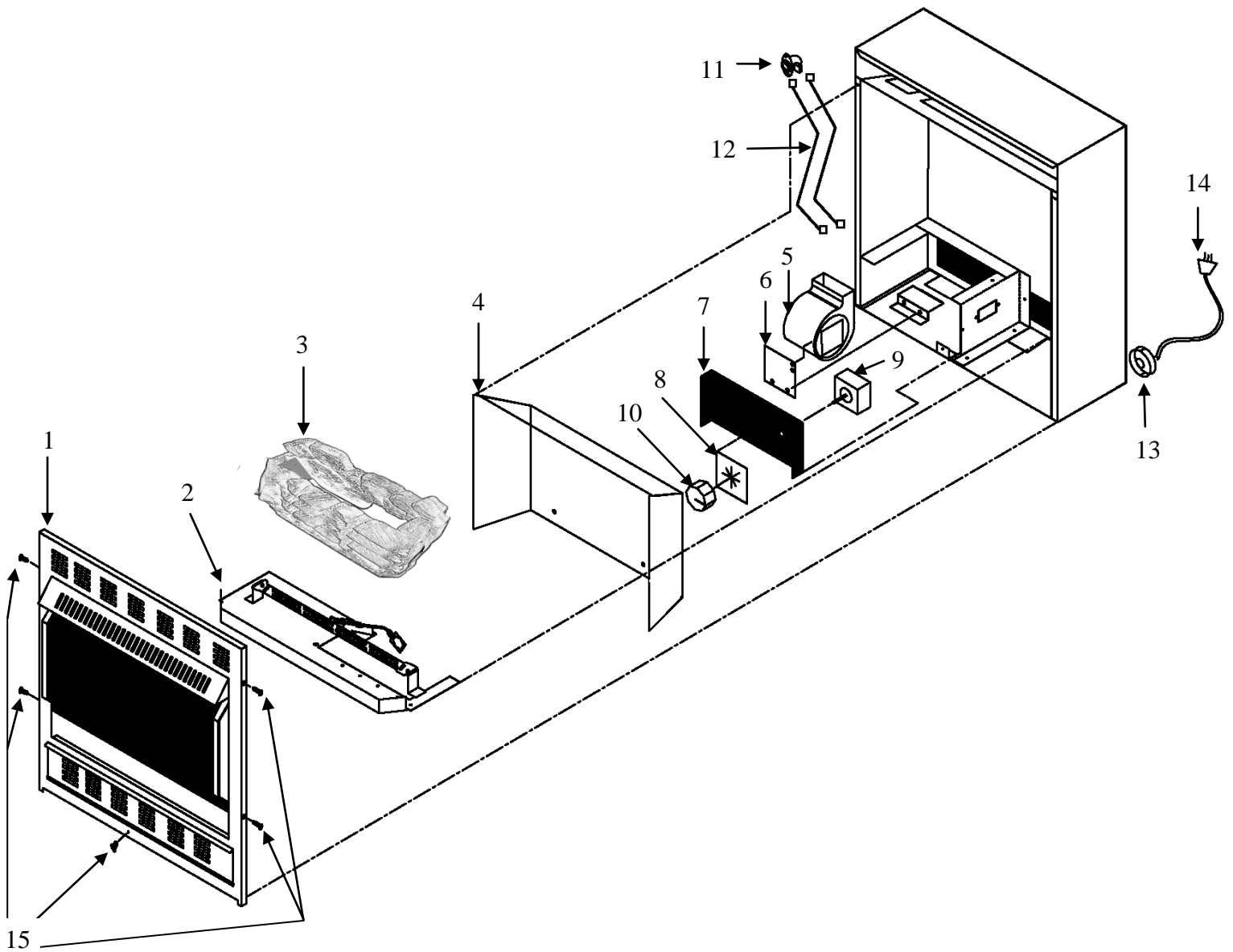

PARTS LIST
MAXITROL VALVE
BURNER SYSTEM

KEY NO.	PART NUMBER	DESCRIPTION		QUANTITY
1	PE GV30B5A2L7B	MAXITROL LP VALVE	<u>OPTIONAL</u>	1
1A	PE GV30B5A2N7B	MAXITROL NATURAL VALVE	<u>OPTIONAL</u>	1
2	PE 4966	3/8" - 3/8" ELBOW		1
3	PS 112736	MAXITROL REGULATOR HOLDER		1
4	PS 113001	INNER BOTTOM/BURNER BASE		1
5	PO TBURN	SINGLE BURNER		1
6	PE TPT100/433	THERMOCOUPLE (COPRECI)		1
7	PE 2150053	COPRECI ODS NAT PILOT	<u>OPTIONAL</u>	1
7A	PE 2150054	COPRECI ODS LP PILOT	<u>OPTIONAL</u>	1
8	PE RV12LF30	MAXITROL REGULATOR-NAT	<u>OPTIONAL</u>	1
8A	PE RV12LF90	MAXITROL REGULATOR-LP	<u>OPTIONAL</u>	1
9	RF 14ALMTUB	1/4" ALUMINUM TUBING		1
10	PH 1166	3/8" STREET ELBOW		1
11	PE 6482	1/4" - 1/8" COMPRESSION ADAPTER		2
12	PO 54ORF-LP	ORIFICE / LP	<u>OPTIONAL</u>	1
12A	PO 42ORF-NAT	ORIFICE / NATURAL	<u>OPTIONAL</u>	1
13	PS 112726	M1127 BURNER SUPPORTS		2
14	PO 38634ALMTUB	3/8" x 6 - 3/4" BURNER TUBE		1
15	PO 54ORFHLD	ANGLED ORIFICE HOLDER		1

BLOWN UP VIEW OF BURNER ASSEMBLY

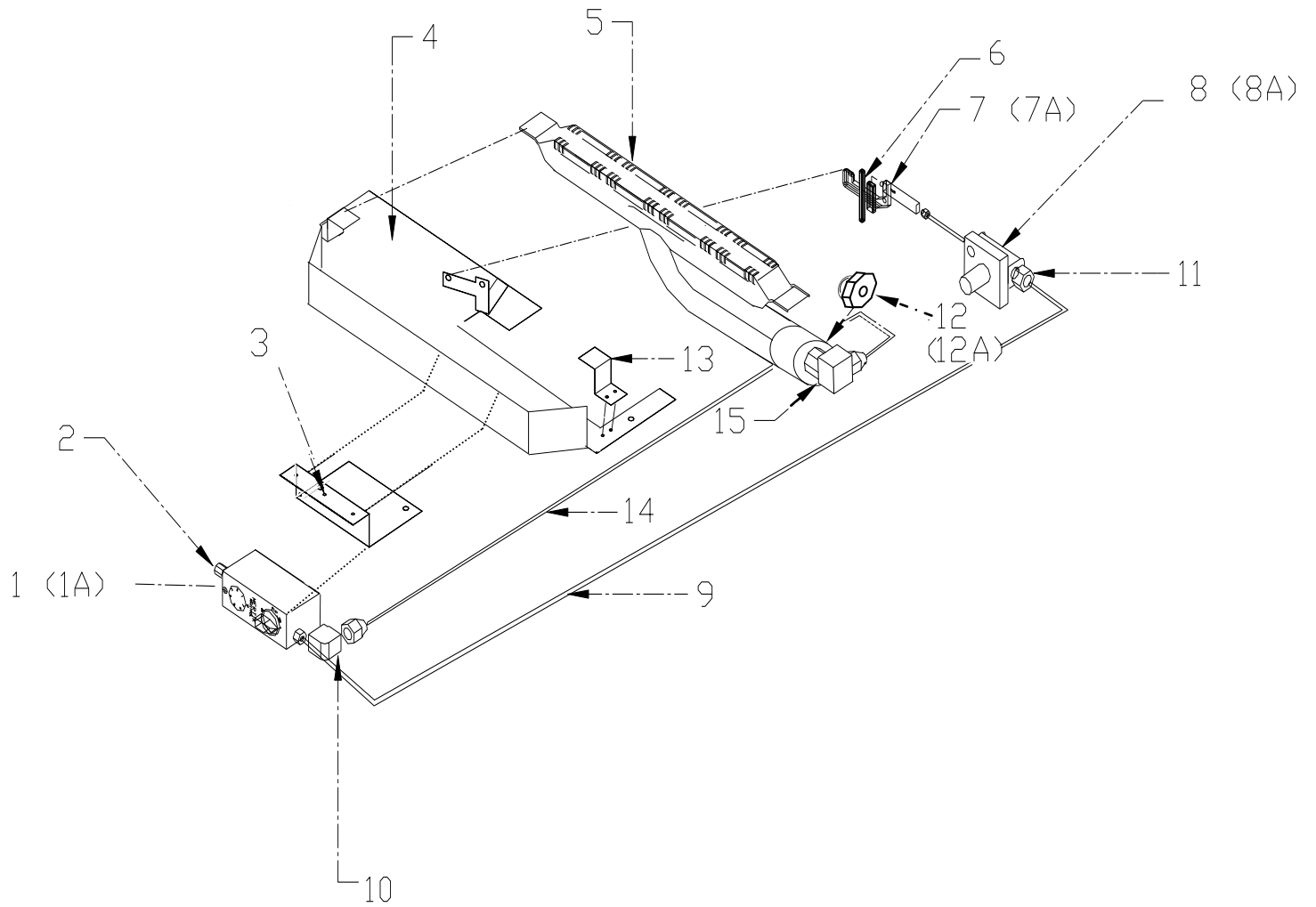

NEW BUCK CORPORATION

We reserve right to amend these specifications at any time without notice. The only warranty applicable is our standard written warranty. We offer no other warranty, expressed or implied.

LIMITED WARRANTY ON VENT-FREE GAS COAL BED HEATER

New Buck warrants this product to be free from defects in materials and components for two (2) years from date of first purchase, provided that product has been properly installed, operated and maintained in accordance with all applicable instructions. To make a claim under this warranty Bill of Sale or canceled check must be presented.

This warranty is extended only to original retail purchaser and covers cost of parts required to restore heater to proper condition. Warranty parts **MUST** be obtained through an authorized Buck Stove dealer and/or New Buck, who will provide original factory replacement parts. Failure to use original factory replacement parts voids this warranty. The heater must be installed by a qualified installer in accordance with all local codes and instructions furnished with unit.

Warranty does not apply to parts that are not in original condition, normal wear and tear or parts that fail or become damaged as a result of misuse, accidents, lack of proper maintenance or defects caused by improper installation.

WARRANTY DOES NOT COVER:

- Removal and re-installation cost
- Labor costs for replacements or repairs
- Transportation
- Cost of service call to diagnose problem
- Painted surfaces
- Damage or defect caused by improper installation, accident, misuse, abuse or alteration

TO FULL EXTENT ALLOWED BY LAW OF JURISDICTION THAT GOVERNS SALE OF PRODUCT, THIS EXPRESS WARRANTY EXCLUDES ANY AND ALL OTHER EXPRESSED WARRANTIES AND LIMITS DURATION OF ANY AND ALL WARRANTIES, INCLUDING WARRANTIES OF MERCHANTABILITY AND FITNESS FOR A PARTICULAR PURPOSE TO ONE (1) YEAR FROM DATE OF FIRST PURCHASE. NEW BUCK LIABILITY IS HEREBY LIMITED TO PURCHASE PRICE OF PRODUCT AND NEW BUCK SHALL NOT BE LIABLE FOR ANY OTHER DAMAGES WHATSOEVER INCLUDING INCIDENTAL OR CONSEQUENTIAL DAMAGES.

Some states do not allow a limitation on how long an implied warranty lasts or an exclusion or limitation of incidental or consequential damages, so above limitation on implied warranties or exclusion on damages may not apply to you.

This warranty gives you specific legal rights. Other rights may vary from state to state.

OWNER REGISTRATION

The attached owner registration card must be completed in its entirety and mailed within 30 days from date of installation in order for warranty coverage to begin to:

New Buck Corporation
P.O. Box 69
Spruce Pine, NC 28777
Email:info@buckstove.com

PLEASE NOTE: Owner Registration Card must contain Authorized Buck Stove Dealer Number and Certified Installer's number (if applicable) for warranty coverage to begin.

NAME: _____

ADDRESS: _____

CITY: _____

STATE: _____ **ZIP:** _____

CUSTOMER EMAIL: _____

MODEL #: 1130 CONTEMPORARY

SERIAL #: _____

DATE OF PURCHASE: _____

DATE OF INSTALLATION: _____

INSTALLER'S NAME: _____

PURCHASED FROM: _____