

MODEL 261 NON-CATALYTIC UNIT

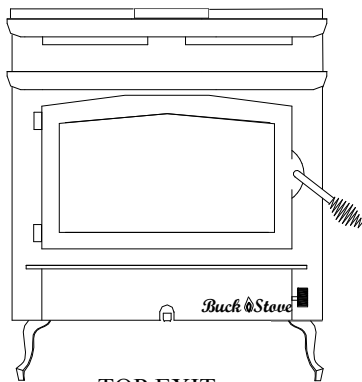

TOP EXIT

OR

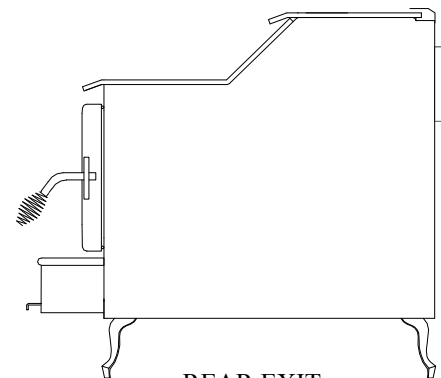

REAR EXIT

FEATURES

PREPARATIONS INSTALLATION
OPERATION MAINTENANCE SAFETY

SAFETY NOTICE

IF THIS HEATER IS NOT PROPERLY INSTALLED, A HOUSE FIRE MAY RESULT. FOR YOUR SAFETY, FOLLOW THE INSTALLATION INSTRUCTIONS. CONTACT THE AUTHORITY HAVE JURISDICTION (SUCH AS MUNICIPAL BUILDING DEPARTMENT, FIRE DEPARTMENT, FIRE PREVENTION BUREAU, ect.) SHOULD BE CONSULTED BEFORE INSTALLATION TO DETERMINE THE NEED TO OBTAIN A PERMIT. KEEP THESE INSTRUCTIONS FOR FUTURE USE.

TESTED AND LISTED BY:



ITS/WARNOCK HERSEY, MIDDLETON, WI

MANUFACTURED BY NEW BUCK CORPORATION - SPRUCE PINE, NC 28777

Revised 1 / 2010

TABLE OF CONTENTS

| | |
|---|----|
| Important Instructions | 2 |
| SECTION I: Introduction..... | 3 |
| Cautions..... | 5 |
| SECTION II: Residential Freestanding Vertical Installation | 6 |
| Minimum Clearances / Floor Protection and Combustibles..... | 6 |
| Preparing Stove For Installation | 7 |
| How to locate chimney exit, and install..... | 8 |
| A. Vertical Exit Using Single Wall Pipe /Listed 2100° UL 103 HT chimney..... | 8 |
| B. Vertical Exit Using DVL Close Clearance Pipe /Listed 2100° UL 103 HT chimney | 10 |
| C. Vertical Wall Exit Using Single Wall Pipe and Elbow /Listed 2100° UL 103 HT Chimney and T-BOX assembly..... | 12 |
| D. Vertical Wall Exit Using DVL Close Clearance Pipe ,and Elbow /Listed 2100° UL 103 HT Chimney and T-BOX assembly | 14 |
| E. Vertical Exit Into Masonry Flue Using Single Wall Pipe and Elbow..... | 16 |
| F. Vertical Exit Into Masonry Flue Using DVL Close Clearance Pipe and Elbow..... | 18 |
| SECTION III: Residential Freestanding Rear Installation | 20 |
| Minimum Clearances / Floor Protection and Combustibles | 20 |
| Preparing Stove For Installation | 21 |
| How to locate chimney exit, and install..... | 22 |
| A. Rear Exit Into Masonry Flue Using Single Wall Pipe | 22 |
| B. Rear Exit Into Masonry Flue Using DVL Close Clearance Pipe | 24 |
| C. Rear Exit to Vertical then Horizontal DVL Close Clearance Pipe and Elbows..... | 26 |
| D. Rear Exit Into Masonry Fireplace using Single Wall Pipe | 28 |
| SECTION IV: Alcove Installation Vertical or Horizontal exit | 30 |
| Minimum Clearances /Floor Protection and Combustibles | 30 |
| Preparing Stove For Installation | 31 |
| How to locate chimney exit, and install..... | 32 |
| (A) Vertical Installation using DVL Close Clearance Pipe. | |
| 1.Alcove Installation: Vertical Exit with standard close clearance shield and pipe shield | 32 |
| 2.Alcove Installation: Horizontal Exit with standard close clearance shield and pipe shield | 34 |
| (B) Rear Installation using DVL Close Clearance Pipe. | |
| 1 Alcove Installation: Rear Exit with standard close clearance shield and pipe shield | 36 |
| SECTION V: Freestanding Mobile Home Installation | 39 |
| Minimum Clearances /Floor Protection and Combustibles | 39 |
| Preparing Stove For Installation | 40 |
| Preparing Heater Location..... | 41 |
| Minimum Clearances to Combustibles | 42 |
| How to locate chimney exit, and install..... | 43 |
| Wood Heater Safety | 46 |
| Operation | 47 |
| Troubleshooting | 48 |
| LIMITED WARRANTY | 50 |

INSTALLATION, OPERATION, AND MAINTENANCE INSTRUCTIONS MODELS 261

READ THIS FIRST

IMPORTANT INSTRUCTIONS

WARNING

THESE UNITS GENERATE A LOT OF HEAT, SO TREAT THEM WITH CARE. **HOT WHILE IN OPERATION!** KEEP CHILDREN, CLOTHING AND FURNITURE AWAY. CONTACT MAY CAUSE SKIN BURNS. READ ALL INSTRUCTIONS BEFORE INSTALLING AND USING THE APPLIANCE. FAILURE TO FOLLOW INSTRUCTIONS MAY RESULT IN PROPERTY DAMAGE, BODILY INJURY, OR EVEN DEATH. SAVE THESE INSTRUCTIONS FOR FUTURE REFERENCES.

- The New Buck Corp. non-catalytic MODEL 261 has been tested by ITS, Warnock Hersey to ANSI/UL Standards 1482.
- Install and operate your units according to instructions provided in this manual. Local building codes may apply; therefore, contact your local building inspector or fire marshal for necessary installation requirements and permits which may go beyond these instructions.
- **If appliance is installed in mobile homes: “DO NOT INSTALL IN SLEEPING ROOMS.”**
- Examine the masonry fireplace and chimney prior to installation of the fireplace accessory to determine that the construction meets the minimum fireplace construction requirements illustrated in the instructions, that it is free from cracks, loose mortar, creosote deposits and other blockage, or other signs of deterioration.

CAUTION

“DO NOT CONNECT THIS UNIT TO A CHIMNEY FLUE SERVING ANOTHER APPLIANCE.” DO NOT USE A FLUE INTENDED FOR A GAS APPLIANCE.”DO NOT CONNECT TO ANY DISTRIBUTION DUCT OR SYSTEM.”

CAUTION

YOUR CHIMNEY OR FLUE MUST BE CORRECTLY SIZED. A CHIMNEY OR FLUE THAT IS TOO SMALL OR LARGE IN DIAMETER, OR TOO SHORT, CAN CAUSE YOUR STOVE TO SPILL SMOKE WHEN THE DOOR IS OPENED.

SECTION I

INTRODUCTION

Your new MODEL 261 is a non-catalytic unit designed to meet the most stringent emissions standards without the use of a catalytic combustor. This effect is achieved through the use of secondary air which is mixed with primary air in the unit's firebox. **For peak performance, we suggest the use of hard seasoned natural wood, loading wood length way from front to rear. You should not burn trash or garbage, artificial or paper logs, gift wrapping, treated or painted wood or any type of coal.**

“DO NOT USE CHEMICALS OR FLUIDS TO START THE FIRE.”

“DO NOT BURN GARBAGE OR FLAMMABLE FLUIDS.”

The primary air, which is controlled by the user, burns the wood. Secondary air is admitted into the firebox through the secondary air tubes at the top of the firebox. This secondary air burns the impurities in the smoke released from the initial wood burning. The temperature necessary for this combustion is maintained through the firebrick refractory. If any more technical information is necessary, contact your local dealer.

Under specific test conditions this heater has been shown to deliver heat at rates ranging from approximately 11,800 to 40,900 BTU/HR.

These unit may also be used with optional room air blower. To order optional motor assembly you must specify the stove model number and give the following part number:

*Model 26-261 Motor Assembly—MA 5126715

For operation and use of this electrical assembly, see instructions provided with the motor assembly kit.

POSSIBLE TOOLS NEEDED FOR INSTALLATION

If you decide to install your own stove, there are several hand tools you may need to do the job. If you do not already have them, they are readily available at most hardware stores.

Caulking gun

Large adjustable wrench (may not be needed)

Drop cloths or newspapers

Vacuum cleaner or whisk broom

Flashlight

1 tube of RTV silicone, Code 103 or 106, or high temperature rubber cement rated between 450° F- 600° F

7/32" drill bit and electric drill

Socket/Ratchet Set

Wrench

Electric Sawzall

INSTALLATION PREPARATION

1. Locate furniture and other materials away from the area stove will be to allow free access .
2. Cover the adjacent floor areas with the drop cloths to protect from soiling or marring the surface.
3. If using an existing flue clean it of ashes and soot.
4. Check the flue for excessive build up of creosote or soot. Also, check for obstructions, such as bird's nests. If the flue is excessively dirty, clean it, or have someone clean it professionally BEFORE installing or using the room heater.
5. If the flue is not used , seal off with metal or tightly packed non-combustible insulation .

CAUTION

THE UNIT IS PAINTED WITH A SPECIALLY FORMULATED HIGH TEMPERATURE PAINT THAT CURES DURING THE FIRST TWO OR THREE FIRINGS. YOU MAY NOTICE A SLIGHT SMOKING EFFECT AND AN ODOR OF BURNING PAINT WHEN YOU BUILD THE FIRST FIRES. THIS IS NORMAL AND IS NOT A CAUSE FOR ALARM. IN SOME CASES, THESE FUMES WILL ACTIVATE A SMOKE ALARM. OPENING A WINDOW NEAR THE UNIT WILL ALLOW THESE FUMES TO ESCAPE. DO NOT BUILD A LARGE, ROARING FIRE UNTIL THIS CURING IS COMPLETE OR THE HEATER FINISH MAY BE DAMAGED.

The connector and/or chimney should be inspected at least once a month during the heating season to determine if a creosote buildup has occurred.

CAUTION

NEVER USE GASOLINE, GASOLINE-TYPE LANTERN FUEL, KEROSENE, CHARCOAL LIGHTER FLUID OR SIMILAR LIQUIDS TO START OR "FRESHEN UP" A FIRE IN THE HEATER. KEEP ALL SUCH LIQUIDS WELL AWAY FROM THE STOVE WHEN IT IS IN USE. ALL FLUIDS OF THIS TYPE GIVE OFF VOLATILE FUMES AND CAN AND WILL EXPLODE!! DON'T TAKE A CHANCE WITH THE SAFETY OF YOUR HOME AND FAMILY.

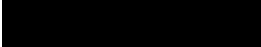

SECTION II



RESIDENTIAL FREESTANDING

VERTICAL EXIT INSTALLATION

For optional vertical exit installation locations refer back to table of contents Section II

MINIMUM CLEARANCES TO FLOOR AND COMBUSTIBLES

See minimum floor protector measurements ,and also for minimum clearances to combustibles, See Pages, and Figures below

- A. Vertical Exit Single Wall Pipe(Page9, Figure3)
- B. Vertical Exit DVL (Page11, Figure5)
- C. Vertical Wall Exit ,Single Wall Pipe, Elbow,103 HT Chimney and T-BOX(Page13, Figure7)
- D. Vertical Wall Exit , DVL Pipe, Elbow,103 HT Chimney and T-BOX(Page15, Figure9)
- E. Vertical Exit to Masonry Flue Single Wall Pipe and Elbow(Page17, Figure11)
- F. Vertical Exit to Masonry Flue DVL Pipe and Elbow(Page19, Figure13)

Floor Protection:

When installing freestanding heater ,a floor protector must be use. Floor protection must be 3/8” minimum thickness non-combustible material or equivalent .R=0.06

How to use alternate materials and how to calculate equivalent thickness.

An easy means of determining if a proposed alternate floor protector meets requirements listed in the appliance manual is to follow this procedure:

1. Convert specification to R-value:
 - R-value is given—no conversion is needed.
 - K- factor is given with a required thickness (T) in inches:
C-factor is given: $R=1/C$
2. Determine the R-value of the proposed alternate floor protector.
 - Use the formula in step (1) to convert values not expressed as “R”
 - For multiple layers, add R-values of each layer to determine the overall R-value.
3. If the overall R-value of the system is grater than the R-value of the specified floor protector, the alternate is acceptable.

Example:

The specified floor protector should be 3/4” thick material with a K-factor of 0.84.
The proposed alternate is 4” brick with a C-factor of 1.25 over 1/8” mineral board with a K-factor of 0.29.

Step (a): Use formula above to convert specification to R-value. $R= 1/K \times T = 1/0.84 \times .75 = 0.893$

Step (b): Calculate R of proposed system. 4” brick of C=1.25, therefore $R_{brick} = 1/C = 1/1.25 = 0.80$ 1/8” mineral board of K = 0.29, therefore $R_{min.bd.} = 1/0.29 \times 0.125 = 0.431$

Step (c): Compare proposed system R of 1.231 to specified R of 0.893. Since proposed system R is greater than required , the system is acceptable.

Definitions:

$$\text{Thermal conductance} = C = \frac{\text{Btu}}{(\text{hr})(\text{ft}^2)(\text{°F})} = \frac{\text{W}}{(\text{m}^2)(\text{°K})}$$

$$\text{Thermal conductance} = K = \frac{(\text{Btu})(\text{inch})}{(\text{hr})(\text{ft}^2)(\text{°f})} = \frac{\text{W}}{(\text{m})(\text{°K})} = \frac{(\text{Btu})}{(\text{hr})(\text{tf})(\text{°F})}$$

$$\text{Thermal conductance} = R = \frac{(\text{ft}^2)(\text{hr})(\text{°F})}{\text{Btu}} = \frac{(\text{m}^2)(\text{°K})}{\text{W}}$$

Select an installation location that will give the best airflow from the front of the heater to the remainder of the home.

PREPARING THE STOVE FOR INSTALLATION

1. Inspect the unit for any obvious physical damage.
2. Plug the power cord into a 115V AC outlet to test the motor and fan when optional motor is being used. "Do not run power cord under unit or in high traffic areas".
3. Check the primary air draft control to ensure that it slides freely.
4. Remove any items from within the firebox. Spread a dropcloth on the floor behind the heater. Next, tilt the heater so that the back is on the drop cloth.
5. Then obtain four legs, attach the legs to holes in bottom of unit with bolts and washers supplied with the leg kit. (See Figure 1).

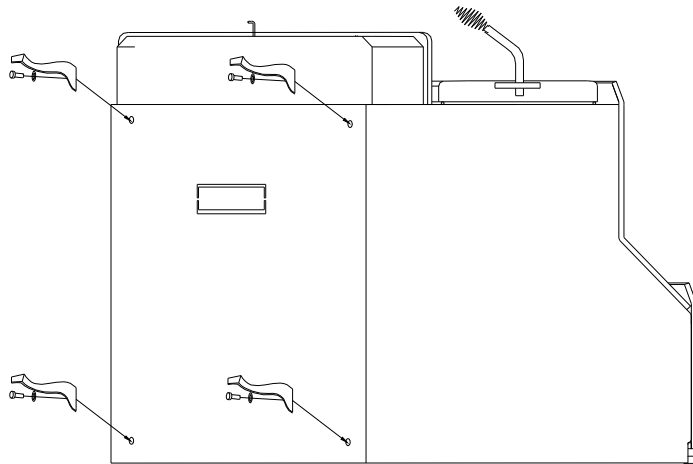

Figure 1.

6. Reposition the heater to the upright position.
7. Next fasten New Buck's Cast Collar part number MA6CHIMCNB to the flue exit of stove to be used, using the J hook's provided. Position collar with gasket towards the unit, tighten the J hook's **Firmly** . (See Figure 2).
8. Fasten New Buck's Flue Collar Plate to the exit not used for burning stove. Firmly secure the Flue Collar Plate Bracket with the nut and washer provided .(See Figure 2).

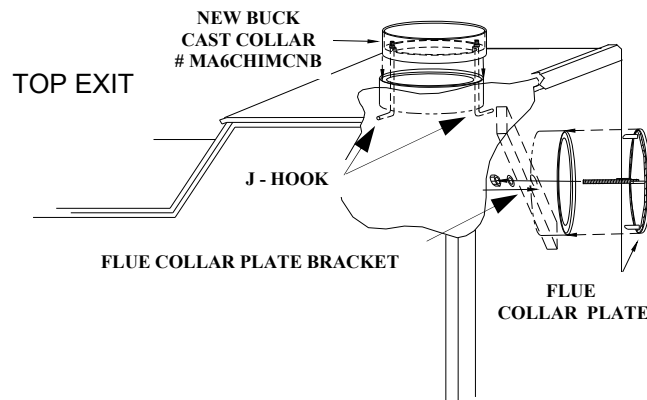

Figure 2.

9. Now the stove is ready to be positioned in the predetermined location.

PREPARING THE ROOM HEATER LOCATION

1. Select an installation location that will give the best airflow from the front of the heater to the remainder of the home.
2. Place the protective floor pad in position.
3. Place the unit on the pad making sure the minimum clearance specifications are met.
4. If connecting to an existing masonry flue, first ensure that the flue conforms to the **NFPA-211** Code and/or consult your local code for proper procedures.

NOTE: This model is designed for connection to: any Listed 2100° UL 103 HT. TYPE chimney also any Listed UL DVL Close Clearance Pipe or Shielded Single wall Pipe. Follow pipe manufactures instructions carefully.

CHIMNEY

This room heater must be converted to (1) a chimney complying with the requirements for Type HT chimneys in the Standard for Chimneys, Factory-Built, Residential, Type and Building Heating Appliance, UL 103, or (2) a code approved masonry chimney with flue liner.



CAUTION: Certain installation types require the use of certain chimney types. Please follow these instructions exactly.

HOW TO LOCATE CHIMNEY EXIT, AND INSTALL

A. Vertical Exit using (6" Single Wall minimum 24 ga. blued or black pipe, and any Listed 2100° UL 103 HT chimney).

With standard close clearance shield and pipe shield

NOTE: For minimum clearances (See Page 9, Figure 3).

1. Suspend a plumb bob from the ceiling above the unit so that the weight is hanging in the center of the flue exit. (A small weight on a string will serve as a plumb bob.) Mark the ceiling where the string is suspended to locate the center of the chimney hole.
2. After locating the center of the hole, install the ceiling support box, chimney or chimney connector, flashing, and rain cap per the chimney manufacturer's instructions, and local building codes for installation through combustible walls or ceilings.
3. Now connect the stove and ceiling support box using minimum #24 ga. blued or black steel connector pipe (**DO NOT USE GALVANIZED PIPE**). Connect each section so the crimped end faces downward, and secure each section to each other using at least three (3) sheet metal screws or rivets. Single wall pipe is to be connected with (3) sheet metal screws or rivets to New Buck Cast Collar, after New Buck Cast Collar Part# MA6CHIMCNB has been attached to stove. (See Page 9, Figure 4).

**A. Vertical exit using (6" Single Wall pipe minimum 24 ga. blued or black pipe and any listed 2100° UL 103 HT. TYPE Chimney).
With standard close clearance shield and pipe shield.
Model 261 minimum clearance to combustibles.**

Figure 3.

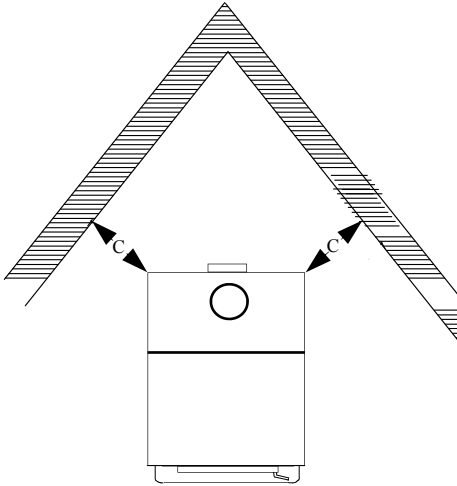
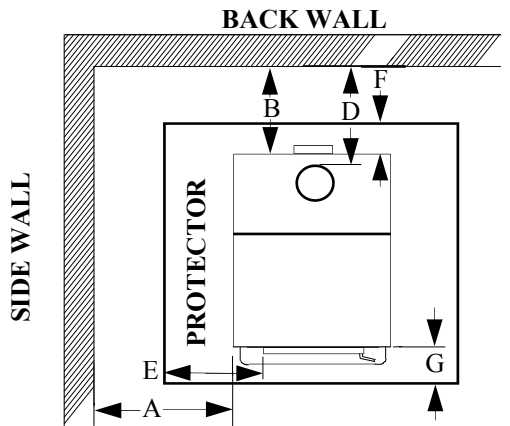

A B C D E F G

MODEL 261 13" 8" 13" 12" 8" 3" 20"

Figure 4.

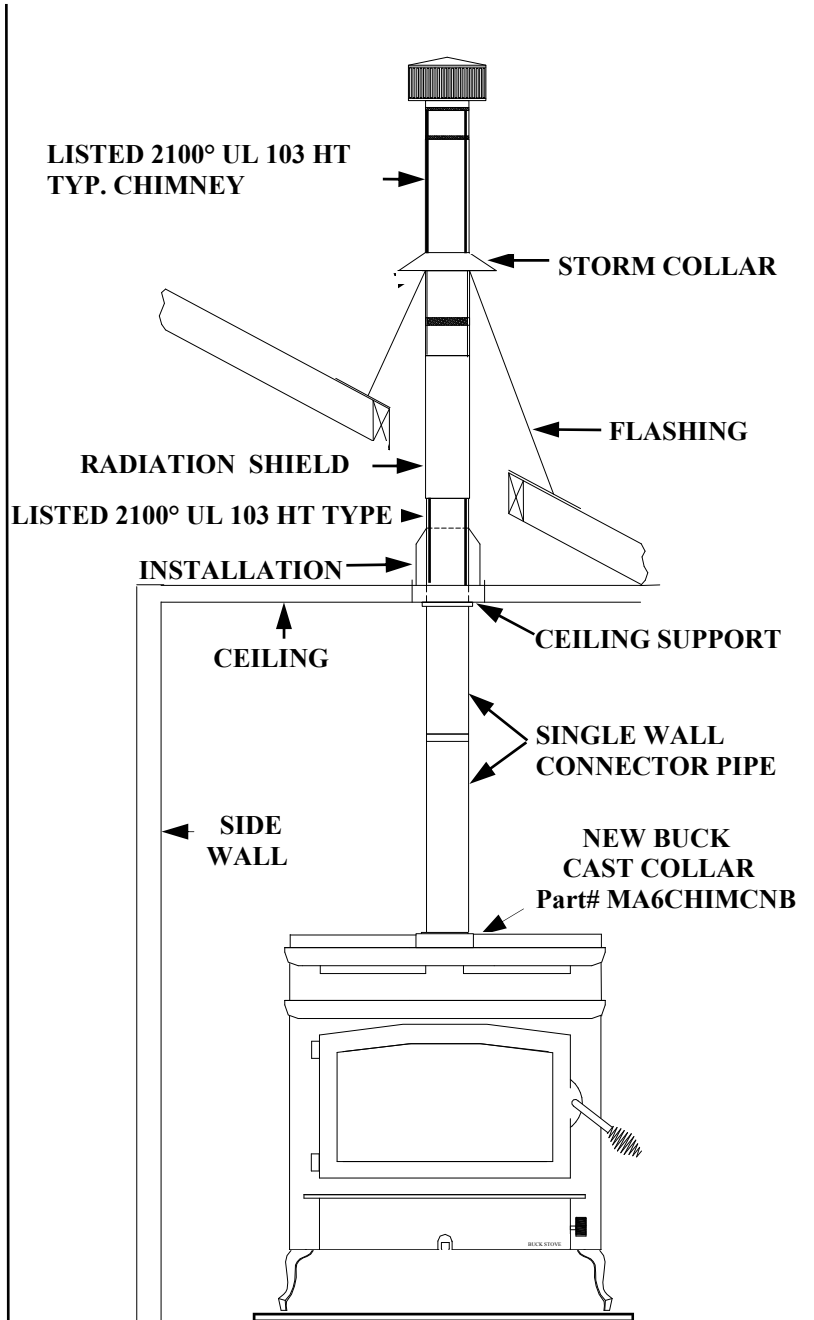

NOTE: All clearances are to combustibles with low clearance shields, and using single wall pipe and minimum floor protector . The clearances above may be reduced. Follow NFPA-211 codes if available or follow instructions on (Pages 10 ,and 11).

NOTE: Model 261 comes standard with low clearance shields.

HOW TO LOCATE CHIMNEY EXIT, AND INSTALL

B. Vertical Exit using (6" DVL Close Clearance pipe, or Shielded Single wall pipe, and any Listed 2100° UL 103 HT chimney).

With standard close clearance shield and pipe shield.

NOTE: For minimum clearances (See Page 11, Figure 5).

1. Suspend a plumb bob from the ceiling above the unit so that the weight is hanging in the center of the flue exit. (A small weight on a string will serve as a plumb bob.) Mark the ceiling where the string is suspended to locate the center of the chimney hole.
2. After locating the center of the hole, install the ceiling support box, chimney or chimney connector, flashing, and rain cap per the chimney manufacturer's instructions, and local building codes for installation through combustible walls or ceilings.
3. Now connect the stove and ceiling support box using DVL close clearance pipe or Shielded Single wall pipe. Connect each section per manufacturer's instructions, and secure each section to each other using minimum (3) sheet metal screws or rivets. DVL close clearance pipe or Shielded Single wall pipe is to be connected with (3) sheet metal screws or rivets to New Buck Cast Collar, after New Buck Cast Collar Part# MA6CHIMCNB has been attached to stove. (See Page 11, Figure 6).

**B. Vertical exit using (6" DVL Close Clearance pipe or Shielded Single wall pipe, and any listed 2100° UL 103 HT. TYPE Chimney).
With standard close clearance shield and pipe shield.
Model 261 minimum clearance to combustibles.**

Figure 5.

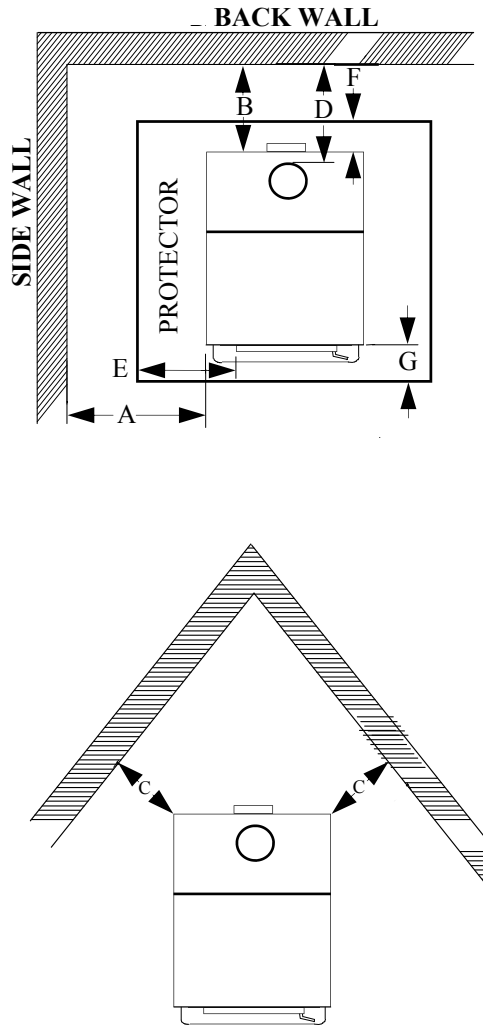

A B C D E F G

MODEL 261 14" 4" 14" 7" 8" 3" 20"

Figure 6.

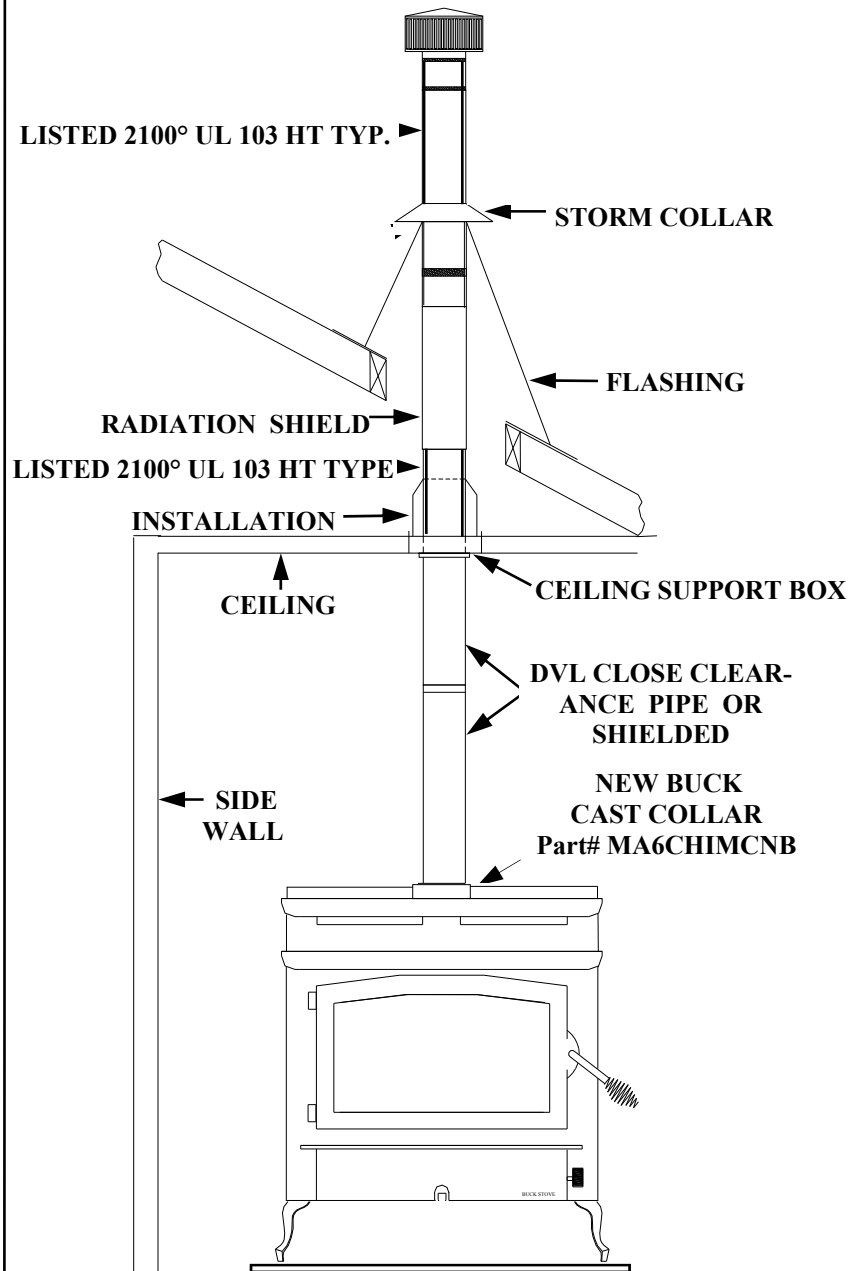

NOTE: All clearances are to combustibles with all low clearance shields and double wall pipe or shielded single wall pipe and minimum floor protector.

NOTE: Model 261 comes standard with low clearance shields.

HOW TO LOCATE CHIMNEY EXIT, AND INSTALL

C. Vertical Wall Exit using (6" Single Wall pipe minimum 24 ga. blued or black with elbow, and any Listed 2100° UL HT chimney and Listed 2100° UL HT T-Box assembly).

With standard close clearance shield and pipe shield

NOTE: For minimum clearances (See Page 13, Figure 7).

1. Mark the plumb line on the wall directly behind the center of the heater.
(See Page 13, Figure 8).
NOTE: When using 24# ga. minimum blue or black steel pipe, "maintain **18" minimum clearances**" between pipe and ceiling.
2. Place the vertical portion of the heater pipe and the elbow in position and project a point onto the plumb line level with the center of the elbow.
3. Measure up so there will be at least 1/4" rise per foot of horizontal connector pipe, maintaining clearances to the ceiling as noted in (Page 13, Figure 8). This will give you the center of the hole for the chimney penetration.
4. After locating the center of the penetration, install the tee-box and chimney as per the chimney manufacturer's specifications.
5. Connect the chimney collar to the tee-box using #24 ga. minimum blued or black steel connector pipe. **DO NOT** use galvanized pipe. Connect each section so the crimped end faces downward, and secure each section to each other using three (3) sheet metal screws or rivets. Single wall pipe is to be connected with (3) sheet metal screws or rivets to New Buck Cast Collar, after New Buck Cast Collar Part# MA6CHIMCNB has been attached to stove. (See Page 13, Figure 8).

**C. Vertical wall exit using (6" Single Wall Pipe minimum 24 ga. blued or black pipe and elbow pipe, and any listed 2100° UL 103 HT. TYPE Chimney and Listed 2100° UL HT T-Box assembly).
With standard close clearance shield and pipe shield.
Model 261 minimum clearance to combustibles.**

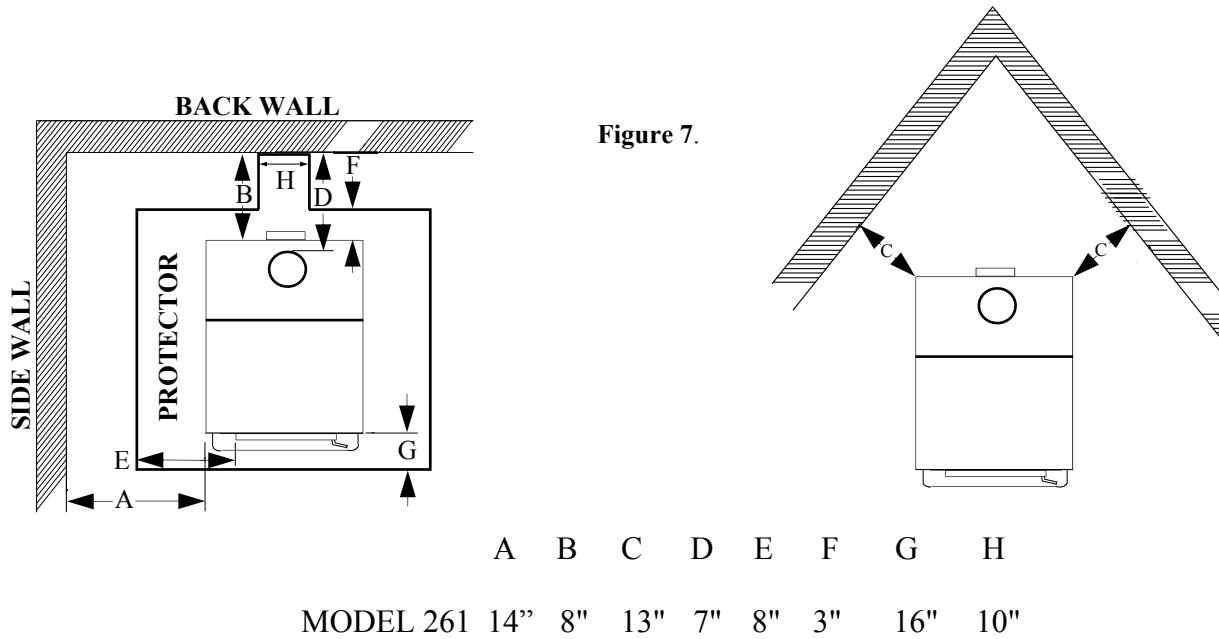

NOTE: All clearances are to combustibles with all low clearance shields and single wall pipe with elbow, and minimum floor protector. **NOTE:** Floor protector must extend length of horizontal flue pipe to wall. **NOTE:** Model 261 comes standard with low clearance shields.

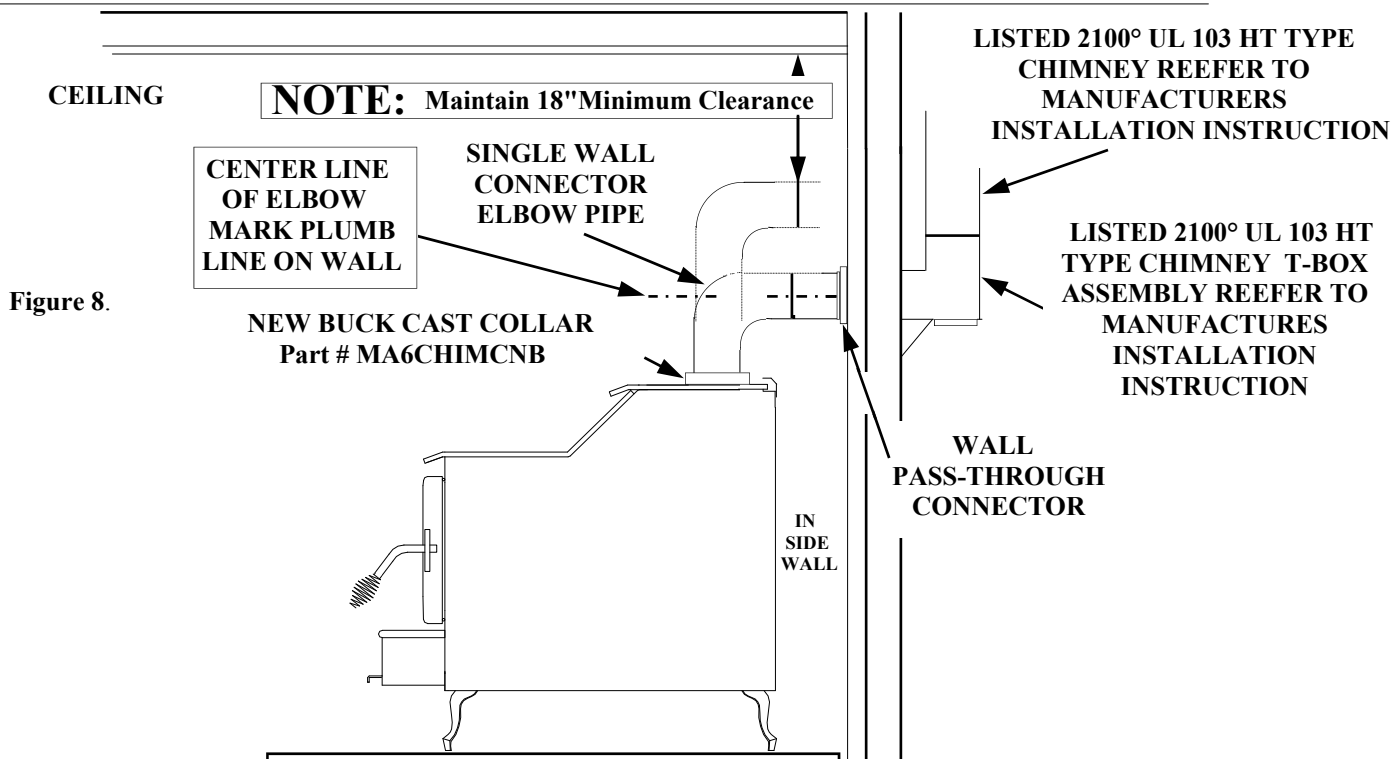

HOW TO LOCATE CHIMNEY EXIT, AND INSTALL

D. Vertical Wall Exit using (6" DVL Close Clearance Pipe and Elbow, and any Listed 2100° UL HT chimney and Listed 2100° UL HT T-Box assembly).

With standard close clearance shield and pipe shield

NOTE: For minimum clearances (See Page 15, Figure 9).

1. Mark the plumb line on the wall directly behind the center of the heater.
(See Page 15, Figure 10.)

NOTE: When using DVL Close Clearance Pipe , **"maintain manufacturers minimum clearances"** between pipe and ceiling.

2. Place the vertical portion of the heater pipe and the elbow in position and project a point onto the plumb line level with the center of the elbow.
3. Measure up so there will be at least 1/4" rise per foot of horizontal connector pipe, maintaining clearances to the ceiling as noted in (Page 15, Figure 10). This will give you the center of the hole for the chimney penetration.
4. After locating the center of the penetration, install the tee-box and chimney as per the chimney manufacturer's specifications.
5. Connect the DVL close clearance pipe to the tee-box per manufacturer's instructions,. DVL close clearance pipe is to be connected with (3) sheet metal screws or rivets to New Buck Cast Collar, after New Buck Cast Collar Part# MA6CHIMCNB has been attached to stove. (See Page 15 ,Figure 10.).

**D. Vertical wall exit using (6" DVL Close Clearance pipe with elbow) ,
and any listed 2100° UL 103 HT. TYPE Chimney).
With standard close clearance shield and pipe shield.
Model 261 minimum clearance to combustibles.**

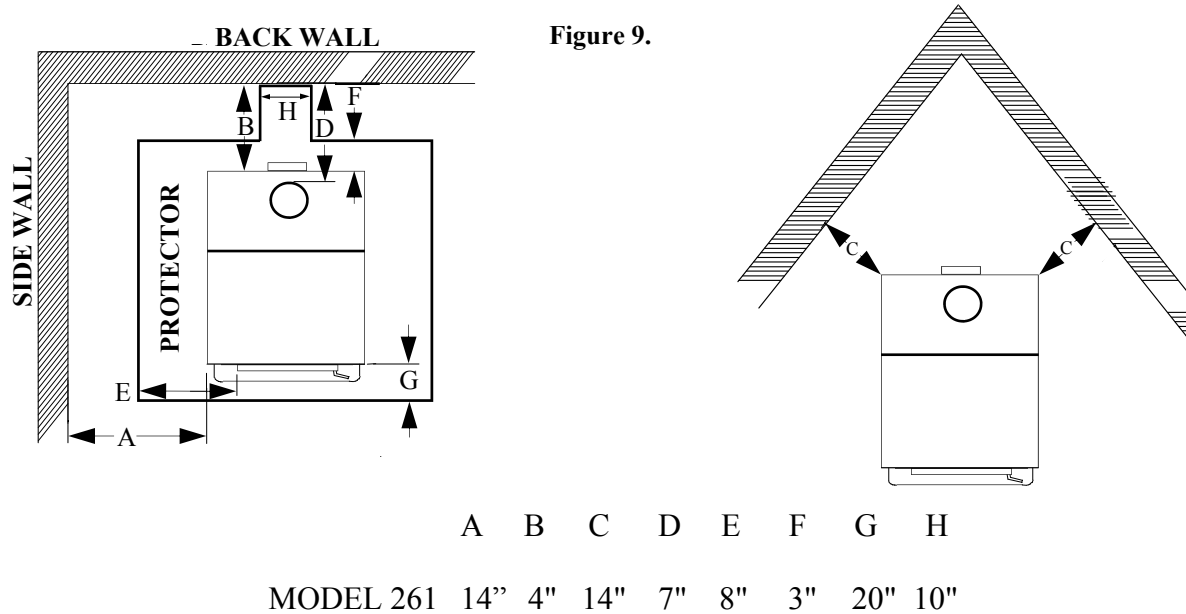

NOTE: All clearances are to combustibles with all low clearance shields and double wall pipe with elbow, and minimum floor protector. **NOTE:** Floor protector must extend length of horizontal flue pipe to wall. **NOTE:** Model 261 comes standard with low clearance shields.

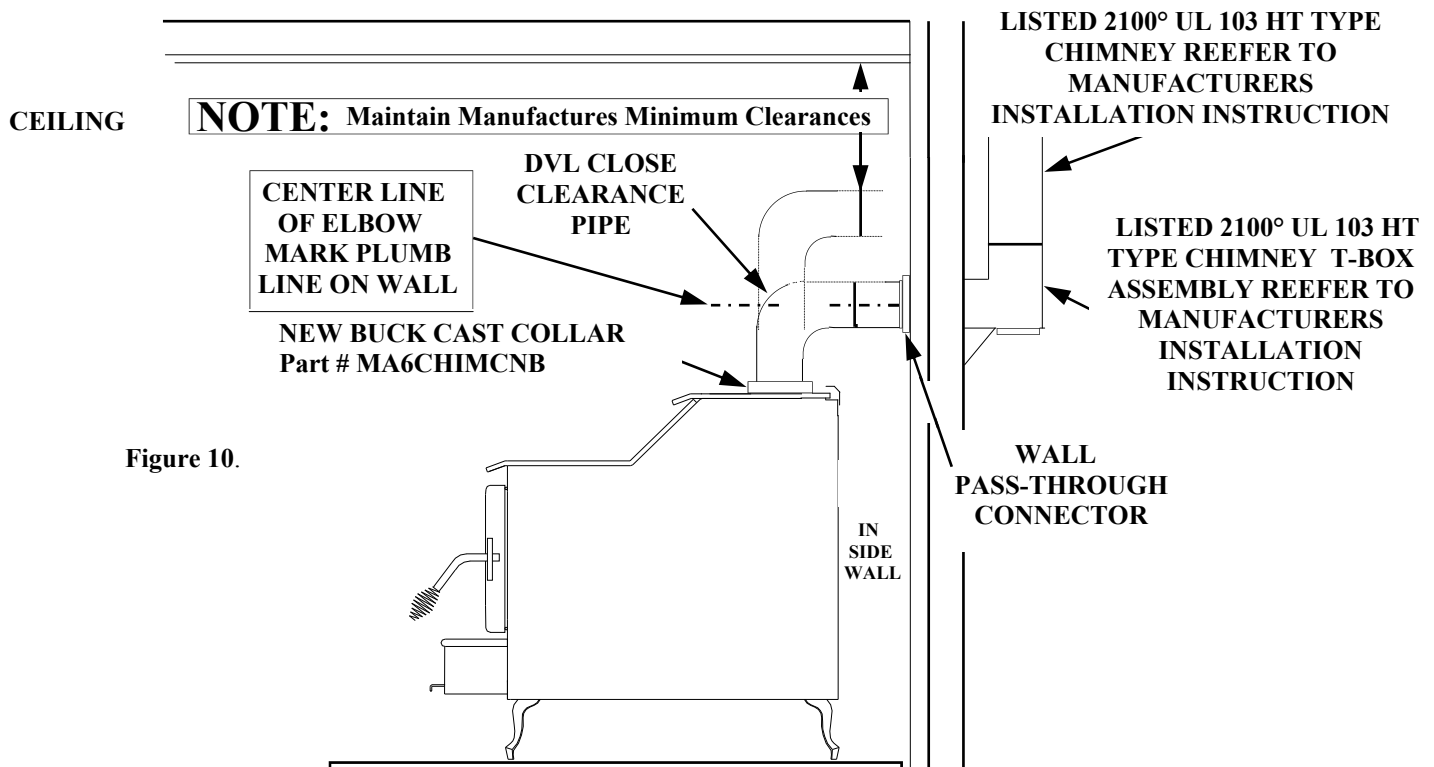

Figure 10.

HOW TO LOCATE CHIMNEY EXIT, AND INSTALL

E. Vertical exit into masonry flue using (6" Single Wall pipe minimum 24 ga. blued or black pipe with Elbow).

With standard close clearance shield and pipe shield.

NOTE: For minimum clearances (See Page 17, Figure 11).

1. Before connecting these units to a masonry chimney, determine that the masonry flue pass-through connector thimble meets the NFPA-211 Code, and local building codes, and is a **minimum of 18"** from the ceiling. If the connector thimble does not meet these codes, the pass-through connector must be modified.

NOTE: When using 24# ga. minimum blue or black steel pipe, "maintain **18" minimum clearances**" between pipe and ceiling.

Connectors may pass through walls or partitions constructed of combustible material if the connector is

- (a) Either listed for wall pass-through or is routed through a device listed for wall pass-through and is installed in accordance with the conditions of the listing.
- (b) Selected or fabricated in accordance with the conditions and clearances as stated in the **NFPA-211** Code. Any unexposed metal that is used as part of a wall pass-through system and is exposed to flue gases shall be constructed of stainless steel or other equivalent material that will resist corrosion, softening, or cracking from flue gases at temperatures up to 1800° F.

In addition, a connector to a masonry chimney shall extend through the wall to the inner face or liner but not beyond, and shall be firmly cemented to masonry.

EXCEPTION: A thimble may be used to facilitate removal of the chimney connector for cleaning, in which case the thimble shall be permanently cemented in place with high-temperature cement.

2. Once the through-the-wall thimble codes are met, simply connect the chimney collar with elbow to the wall pass-through connector using #24 ga. minimum, blue or black steel connector pipe as follows:
 - (a) Maintain 1/4" rise per foot (horizontal length) from the appliance to the chimney.
 - (b) Connect each section so the crimped end faces downward.
 - (c) Secure each section to each other using at least three (3) sheet metal screws or rivets.
 - (d) Use three (3) sheet metal screws to fasten pipe to New Buck Cast Collar onto heater. after New Buck Cast Collar Part# MA6CHIMCNB has been attached to stove.
(See Page 17 Figure 12).

**E. Vertical exit into masonry flue using (6" Single Wall pipe minimum 24 ga blued or black pipe with elbow)
With standard close clearance shield and pipe shield.
Model 261 minimum clearance to combustibles.**

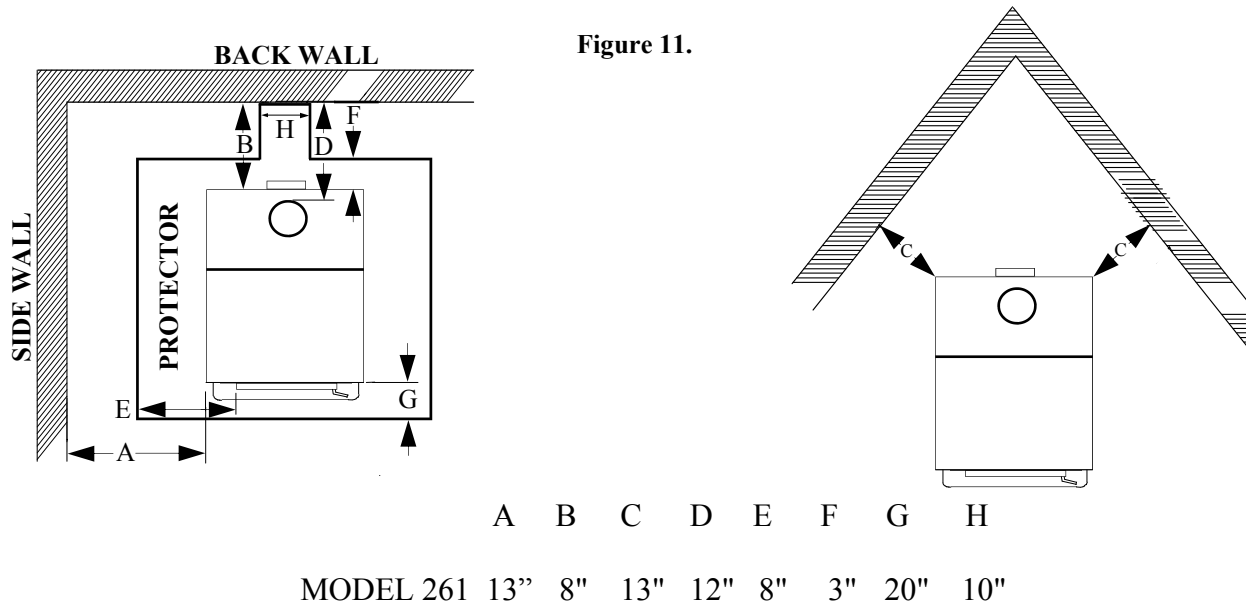

Figure 11.

NOTE: All clearances are to combustibles with all low clearance shields and single wall pipe with elbow, and minimum floor protector. **NOTE:** Floor protector must extend length of horizontal flue pipe to wall. **NOTE:** Model 261 comes standard with low clearance shields.

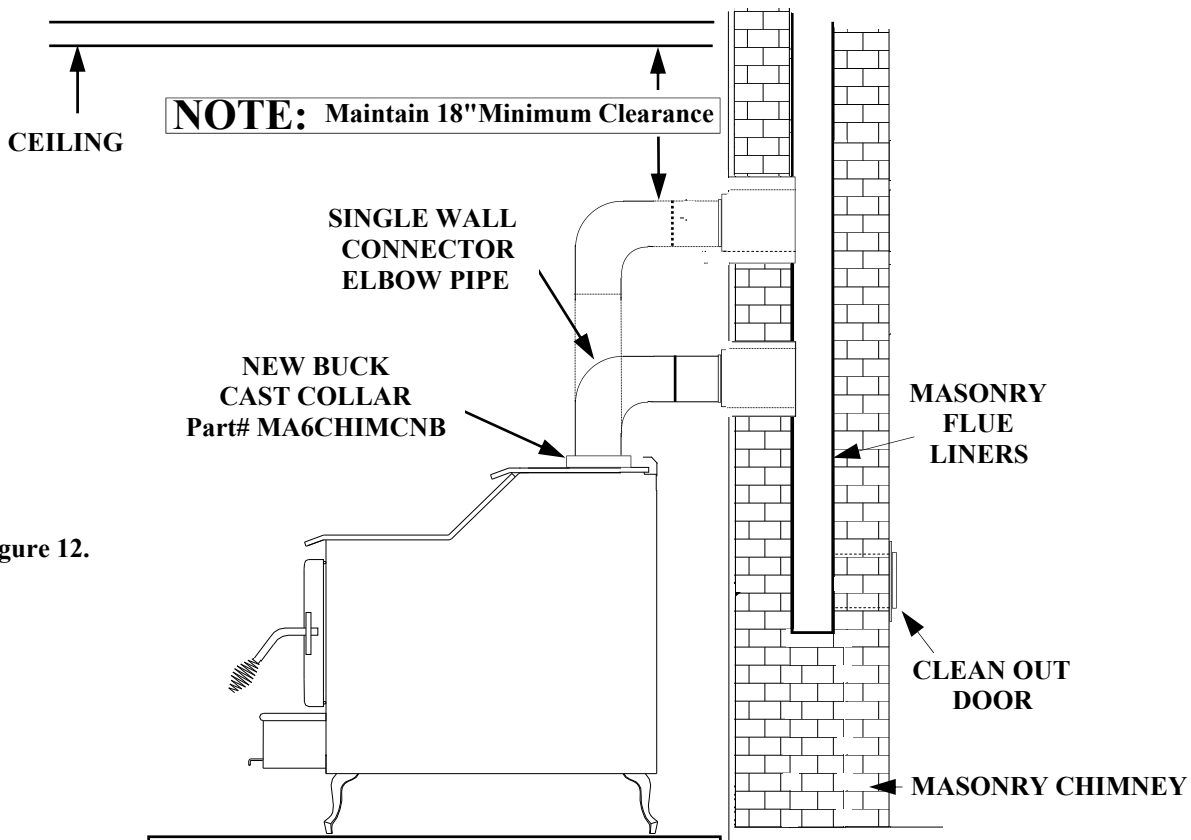

Figure 12.

HOW TO LOCATE CHIMNEY EXIT, AND INSTALL

F. Vertical exit into masonry flue using (6" DVL Close Clearance pipe with Elbow). With standard close clearance shield and pipe shield.

NOTE: For minimum clearances (See Page 19, Figure 13).

1. Before connecting these units to a masonry chimney, determine that the masonry flue pass-through connector thimble meets the NFPA-211 Code, and local building codes “**maintain manufacturers minimum clearances**” from the ceiling. If the connector thimble does not meet these codes, the pass-through connector must be modified.

Connectors may pass through walls or partitions constructed of combustible material if the connector is

- (a) Either listed for wall pass-through or is routed through a device listed for wall pass-through and is installed in accordance with the conditions of the listing.
- (b) Selected or fabricated in accordance with the conditions and clearances as stated in the **NFPA-211** Code. Any unexposed metal that is used as part of a wall pass-through system and is exposed to flue gases shall be constructed of stainless steel or other equivalent material that will resist corrosion, softening, or cracking from flue gases at temperatures up to 1800° F.

In addition, a connector to a masonry chimney shall extend through the wall to the inner face or liner but not beyond, and shall be firmly cemented to masonry.

NOTE: When using DVL Close Clearance Pipe, “**maintain manufacturers minimum clearances**” between pipe and ceiling.

EXCEPTION: A thimble may be used to facilitate removal of the chimney connector for cleaning, in which case the thimble shall be permanently cemented in place with high-temperature cement.

2. Once the through-the-wall thimble codes are met, simply connect the DVL Close Clearance pipe or Shielded Single wall Pipe with elbow to the wall pass-through connector per chimney manufacturers instruction.
 - (a) Maintain 1/4" rise per foot (horizontal length) from the appliance to the chimney.
 - (b) Connect each section so the crimped end faces downward.
 - (c) Secure each section to each other using at least three (3) sheet metal screws or rivets.
 - (d) Use three (3) sheet metal screws to fasten pipe to New Buck Cast Collar on heater. after New Buck Cast Collar Part# MA6CHIMCNB has been attached to stove. (See Page 19 Figure 14).

**F. Vertical exit using (6" DVL Close Clearance pipe with Elbow) into masonry flue.
 With standard close clearance shield and pipe shield.
 Model 261 minimum clearance to combustibles.**

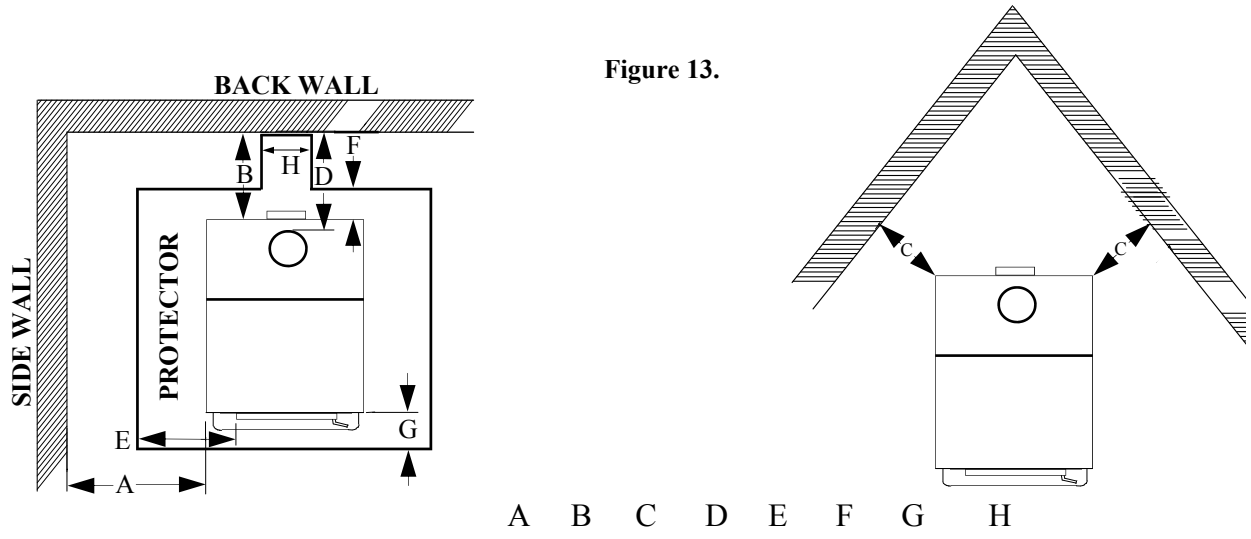

Figure 13.

| | | | | | | | | |
|-----------|-----|----|-----|----|----|----|-----|-----|
| A | B | C | D | E | F | G | H | |
| MODEL 261 | 14" | 4" | 14" | 7" | 8" | 3" | 20" | 10" |

NOTE: All clearances are to combustibles with all low clearance shields and single wall pipe with elbow, and minimum floor protector. **NOTE:** Floor protector must extend length of horizontal flue pipe to wall. **NOTE:** Model 261 comes standard with low clearance shields.

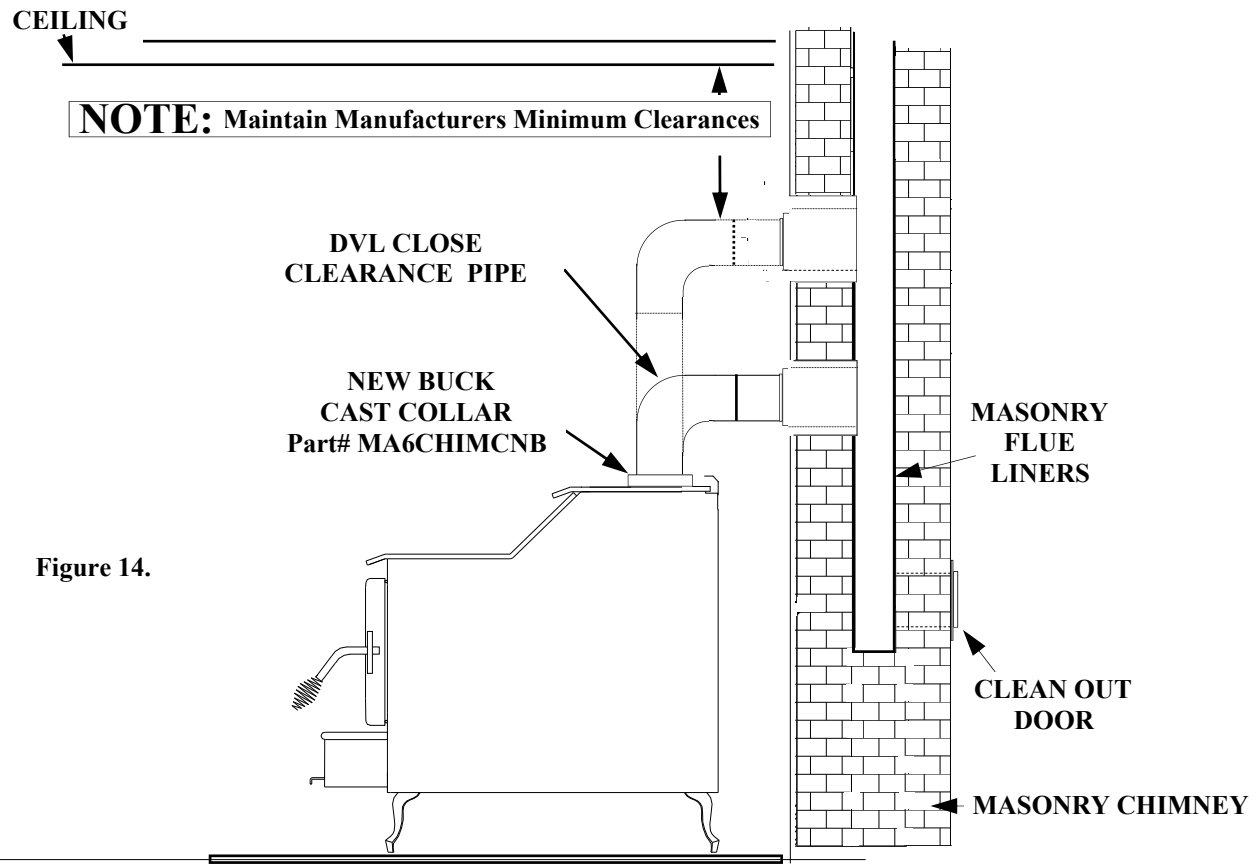

Figure 14.

SECTION III

RESIDENTIAL FREESTANDING REAR EXIT INSTALLATION

**For optional rear exit installation locations refer back to
table of contents Section III**

MINIMUM CLEARANCES TO FLOOR AND COMBUSTIBLES

See minimum floor protector measurements ,and also for minimum clearances to combustibles, (Pages, and Figures below)

- A. Rear Exit Into Masonry Flue Using Single Wall Pipe(Page23, Figure17)
- B. B. Rear Exit Into Masonry Flue Using DVL Close Clearance Pipe(Page25, Figure19)
- C. Rear Exit Vertical to Horizontal DVL Close Clearance Pipe and Elbows(Page27, Figure21)
- D. Rear Exit Into Masonry Fireplace using Single Wall Pipe(Page28, Figure23,and Page29, Figure24)

Floor Protection:

When installing freestanding heater ,a floor protector must be use. Floor protection must be 3/8” minimum thickness non-combustible material or equivalent .R=0.06

How to use alternate materials and how to calculate equivalent thickness.

An easy means of determining if a proposed alternate floor protector meets requirements listed in the appliance manual is to follow this procedure:

1. Convert specification to R-value:
 - R-value is given—no conversion is needed.
 - K- factor is given with a required thickness (T) in inches:
 - C-factor is given: $R=1/C$
2. Determine the R-value of the proposed alternate floor protector.
 - Use the formula in step (1) to convert values not expressed as “R”
 - For multiple layers, add R-values of each layer to determine the overall R-value.
3. If the overall R-value of the system is grater than the R-value of the specified floor protector, the alternate is acceptable.

Example:

The specified floor protector should be 3/4” thick material with a K-factor of 0.84.

The proposed alternate is 4” brick with a C-factor of 1.25 over 1/8” mineral board with a K-factor of 0.29.

Step (a): Use formula above to convert specification to R-value. $R= 1/K \times T = 1/0.84 \times .75 = 0.893$

Step (b): Calculate R of proposed system. 4” brick of C=1.25, therefore $R_{brick} = 1/C = 1/1.25 = 0.80$ 1/8” mineral board of K = 0.29, therefore $R_{min.bd.} = 1/0.29 \times 0.125 = 0.431$

Step (c): Compare proposed system R of 1.231 to specified R of 0.893. Since proposed system R is greater than required , the system is acceptable.

Definitions:

$$\text{Thermal conductance} = C = \frac{\text{Btu}}{(\text{hr})(\text{ft}^2)(\text{°F})} = \frac{\text{W}}{(\text{m}^2)(\text{°K})}$$

$$\text{Thermal conductance} = K = \frac{(\text{Btu})(\text{inch})}{(\text{hr})(\text{ft}^2)(\text{°f})} = \frac{\text{W}}{(\text{m})(\text{°K})} = \frac{(\text{Btu})}{(\text{hr})(\text{tf})(\text{°F})}$$

$$\text{Thermal conductance} = R = \frac{(\text{ft}^2)(\text{hr})(\text{°F})}{\text{Btu}} = \frac{(\text{m}^2)(\text{°K})}{\text{W}}$$

Select an installation location that will give the best airflow from the front of the heater to the remainder of the home.

PREPARING THE STOVE FOR INSTALLATION

1. Inspect the unit for any obvious physical damage.
2. Plug the power cord into a 115V AC outlet to test the motor and fan when optional motor is being used. "Do not run power cord under unit or in high traffic areas".
3. Check the primary air draft control to ensure that it slides freely.
4. Remove any items from within the firebox. Spread a dropcloth on the floor behind the heater. Next, tilt the heater so that the back is on the drop cloth.
5. Then obtain four legs, attach the legs to holes in bottom of unit with bolts and washers supplied with the leg kit. (See Figure 15).

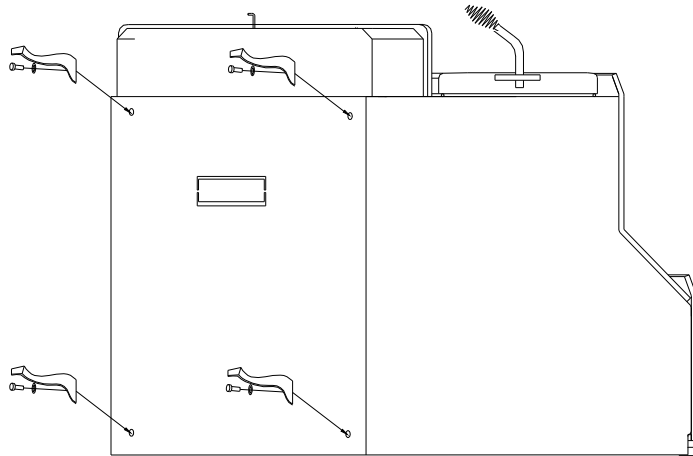

Figure 15.

6. Reposition the heater to the upright position.
7. Next fasten New Buck's Cast Collar Part number MA6CHIMNB to the flue exit of stove to be used, using the J hook's provided. Position collar with gasket towards the unit, tighten the J hook's **Firmly** secured. (See Figure 16).
8. Fasten New Buck's Flue Collar Plate to the exit not used for burning stove. **Firmly** secure the Flue Collar Plate Bracket with the nut and washer provided. (See Figure 16).

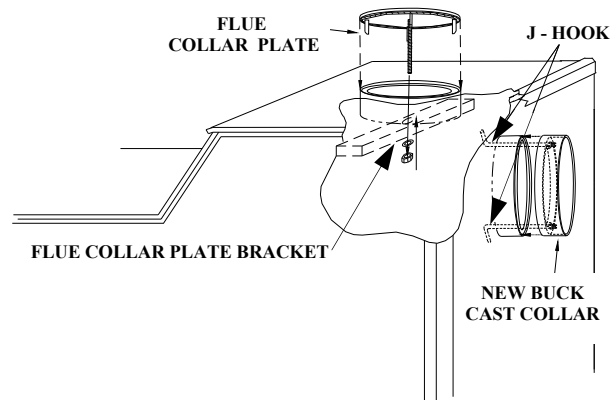

Figure 16.

9. Now the stove is ready to be positioned in the predetermined location.

PREPARING THE ROOM HEATER LOCATION

1. Select an installation location that will give the best airflow from the front of the heater to the remainder of the home.
2. Place the protective floor pad in position.
3. Place the unit on the pad making sure the minimum clearance specifications are met.
4. If connecting to an existing masonry flue, first ensure that the flue conforms to the **NFPA-211** Code and/or consult your local code for proper procedures.

This model is designed for connection to: any Listed 2100° UL 103 HT. TYPE chimney also any Listed UL DVL Close Clearance Pipe. Follow pipe manufactures instructions carefully.

CHIMNEY

This room heater must be converted to (1) a chimney complying with the requirements for Type HT chimneys in the Standard for Chimneys, Factory-Built, Residential, Type and Building Heating Appliance, UL 103, or (2) a code approved masonry chimney with a flue liner.



CAUTION: Certain installation types require the use of certain chimney types. Please follow these instructions exactly.

HOW TO LOCATE CHIMNEY EXIT, AND INSTALL

A. Rear exit Into Masonry Flue using (6" Single Wall Pipe minimum 24 ga. blued or black pipe). With standard close clearance shield and pipe shield.

NOTE: For minimum clearances (See Page 23, Figure 17).

1. Before connecting these units to a masonry chimney, determine that the masonry flue pass-through connector thimble meets the NFPA-211 Code and local building codes and is a minimum of 18" from the ceiling. If the connector thimble does not meet these codes, the pass-through connector must be modified.

Connectors may pass through walls or partitions constructed of combustible material if the connector is

- (a) Either listed for wall pass-through or is routed through a device listed for wall pass-through and is installed in accordance with the conditions of the listing.
- (b) Selected or fabricated in accordance with the conditions and clearances as stated in the **NFPA-211** Code. Any unexposed metal that is used as part of a wall pass-through system and is exposed to flue gases shall be constructed of stainless steel or other equivalent material that will resist corrosion, softening, or cracking from flue gases at temperatures up to 1800° F.

In addition, a connector to a masonry chimney shall extend through the wall to the inner face or liner but not beyond, and shall be firmly cemented to masonry.

EXCEPTION: A thimble may be used to facilitate removal of the chimney connector for cleaning, in which case the thimble shall be permanently cemented in place with high-temperature cement.

2. Once the through-the-wall thimble codes are met, simply connect the (Single Wall Pipe minimum 24 ga. blue or black pipe or DVL Close Clearance pipe) to the wall pass-through connector per chimney manufactures instruction.
 - (a) Maintain 1/4" rise per foot (horizontal length) from the appliance to the chimney.
 - (b) Connect each section so the crimped end faces towards stove.
 - (c) Secure each section to each other using at least three (3) sheet metal screws or rivets.
 - (d) Use three (3) sheet metal screws to fasten pipe to New Buck Cast Collar on heater. after New Buck Cast Collar Part# MA6CHIMCNB has been attached to stove. (See Page 23 Figure 18).

**A. Rear exit into Masonry Flue using (6" Single Wall pipe minimum 24 ga blued or black pipe).
With standard close clearance shield and pipe shield.
Model 261 minimum clearance to combustibles.**

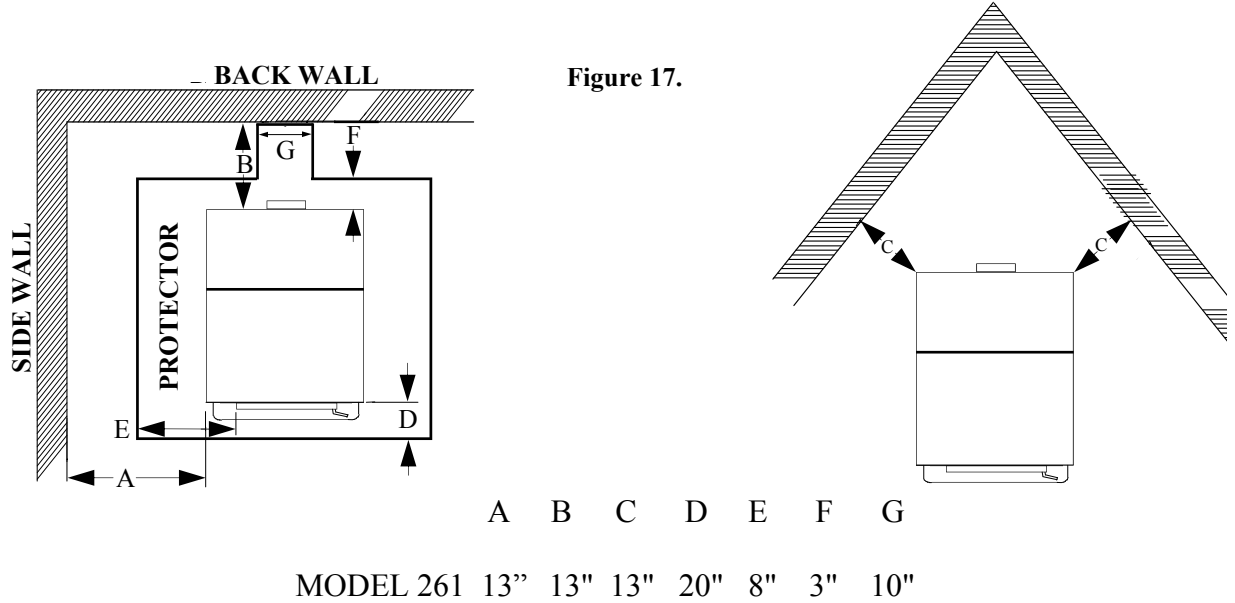

Figure 17.

NOTE: All clearances are to combustibles with all low clearance shields and single wall pipe , and minimum floor protector. **NOTE:** Floor protector must extend length of horizontal flue pipe to wall. **NOTE:** Model 261 comes standard with low clearance shields.

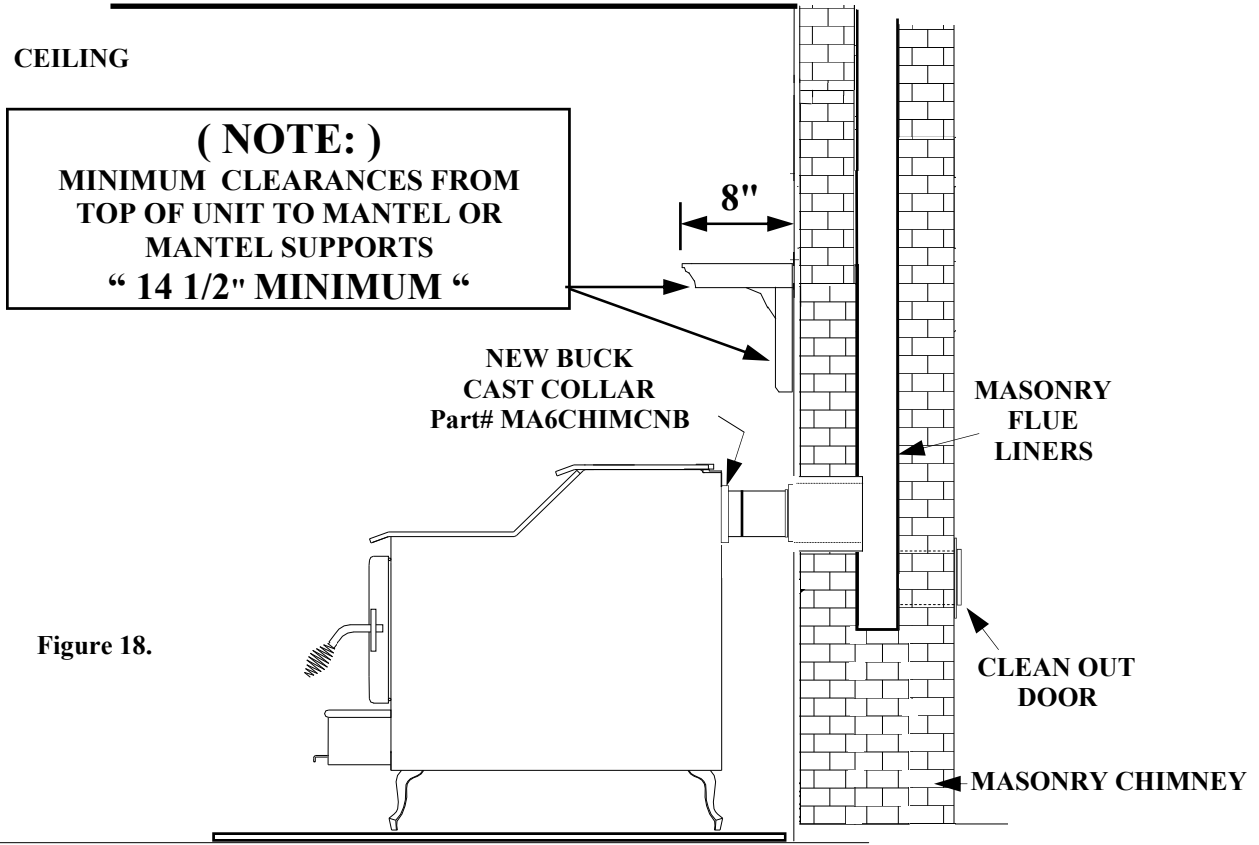

Figure 18.

HOW TO LOCATE CHIMNEY EXIT, AND INSTALL

B. Rear exit into Masonry Flue (6" Using DVL Close Clearance Pipe).

With standard close clearance shield and pipe shield.

NOTE: For minimum clearances (See Page 25, Figure 19).

1. Before connecting these units to a masonry chimney, determine that the masonry flue pass-through connector thimble meets the NFPA-211 Code and local building codes and is a minimum of 18" from the ceiling. If the connector thimble does not meet these codes, the pass-through connector must be modified.

Connectors may pass through walls or partitions constructed of combustible material if the connector is

- (a) Either listed for wall pass-through or is routed through a device listed for wall pass-through and is installed in accordance with the conditions of the listing.
- (b) Selected or fabricated in accordance with the conditions and clearances as stated in the **NFPA-211** Code. Any unexposed metal that is used as part of a wall pass-through system and is exposed to flue gases shall be constructed of stainless steel or other equivalent material that will resist corrosion, softening, or cracking from flue gases at temperatures up to 1800° F.

In addition, a connector to a masonry chimney shall extend through the wall to the inner face or liner but not beyond, and shall be firmly cemented to masonry.

EXCEPTION: A thimble may be used to facilitate removal of the chimney connector for cleaning, in which case the thimble shall be permanently cemented in place with high-temperature cement.

2. Once the through-the-wall thimble codes are met, simply connect the (Single Wall Pipe minimum 24 ga. blued or black pipe or DVL Close Clearance pipe) to the wall pass-through connector per chimney manufacturers instruction.
 - (a) Maintain 1/4" rise per foot (horizontal length) from the appliance to the chimney.
 - (b) Connect each section so the crimped end faces towards stove.
 - (c) Secure each section to each other using at least three (3) sheet metal screws or rivets.
 - (d) Use three (3) sheet metal screws to fasten pipe to New Buck Cast Collar on heater. after New Buck Cast Collar Part# MA6CHIMCNB has been attached to stove. (See Page 25 Figure 20).

**B. Rear exit into Masonry Flue using (6" DVL Close Clearance pipe).
 With standard close clearance shield and pipe shield.
 Model 261 minimum clearance to combustibles.**

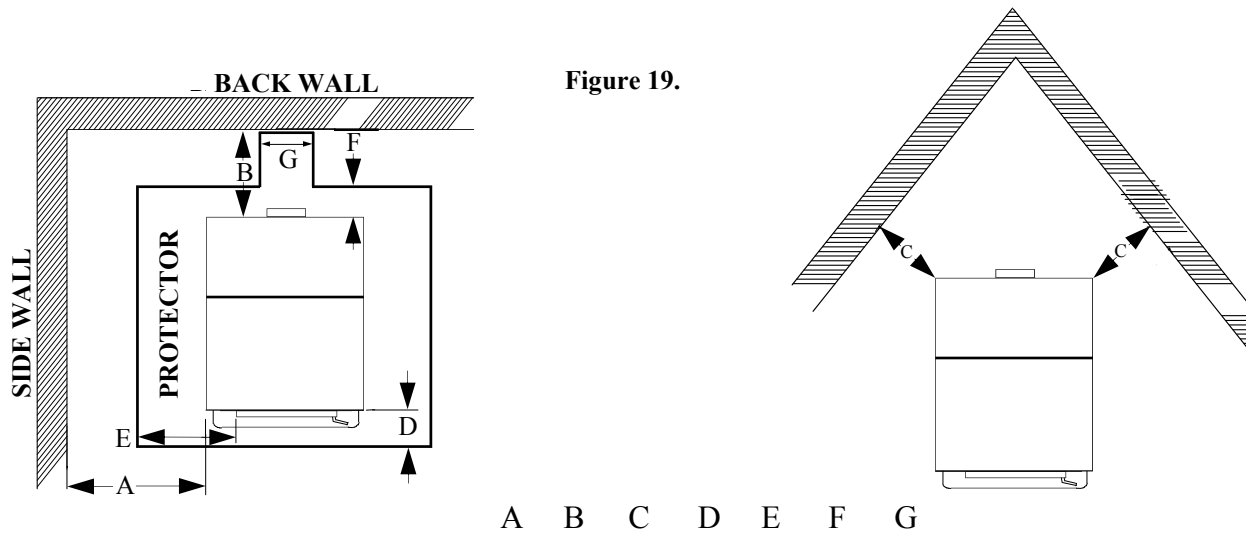

MODEL 261 13" 13" 13" 20" 8" 3" 10"

NOTE: All clearances are to combustibles with all low clearance shields and Double wall pipe , and minimum floor protector.**NOTE:** Floor protector must extend length of horizontal flue pipe to wall. **NOTE:** Model 261 comes standard with low clearance shields.

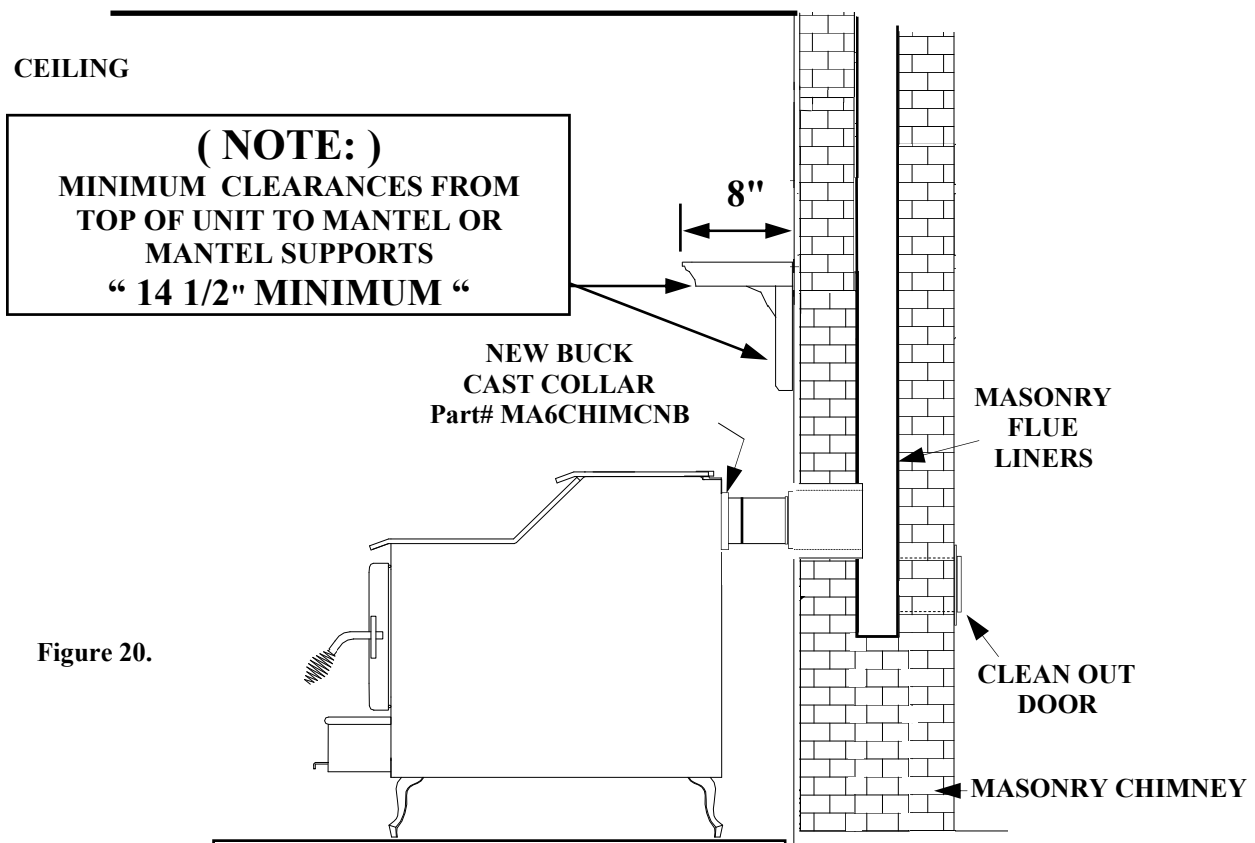

HOW TO LOCATE CHIMNEY EXIT, AND INSTALL

C. Rear Exit to Vertical then to Horizontal into Masonry Flue using (6" DVL Close Clearance pipe and Elbow's).

With standard close clearance shield and pipe shield.

NOTE: For minimum clearances (See Page 27, Figure 21).

Before connecting these units to a masonry chimney, determine that the masonry flue pass-through connector thimble meets the NFPA-211 Code, and local building codes, **"maintain manufacturers minimum clearances"** from the ceiling. If the connector thimble does not meet these codes, the pass-through connector must be modified.

Connectors may pass through walls or partitions constructed of combustible material if the connector is

- (a) Either listed for wall pass-through or is routed through a device listed for wall pass-through and is installed in accordance with the conditions of the listing.
- (b) Selected or fabricated in accordance with the conditions and clearances as stated in the **NFPA-211** Code. Any unexposed metal that is used as part of a wall pass-through system and is exposed to flue gases shall be constructed of stainless steel or other equivalent material that will resist corrosion, softening, or cracking from flue gases at temperatures up to 1800° F.

In addition, a connector to a masonry chimney shall extend through the wall to the inner face or liner but not beyond, and shall be firmly cemented to masonry.

EXCEPTION: A thimble may be used to facilitate removal of the chimney connector for cleaning, in which case the thimble shall be permanently cemented in place with high-temperature cement. Once the through-the-wall thimble codes are met,

1. Mark the plumb line on the wall directly behind the center of the heater.

(See Page 27, Figure 22.)

NOTE: When using DVL Close Clearance Pipe, **"maintain manufacturers minimum clearances"** between pipe and ceiling.

2. Place one elbow on to the New Buck Cast Collar, then vertical portion of the heater pipe and the next elbow in position and project a point onto the plumb line level with the center of the elbow.
3. Measure up so there will be at least 1/4" rise per foot of horizontal connector pipe, maintaining clearances to the ceiling as noted in Page 27, Figure 22. This will give you the center of the hole for the chimney penetration.
4. After locating the center of the penetration. The thimble shall be permanently cemented in place with high-temperature cement
5. Once the through-the-wall thimble codes are met, simply connect the DVL Close Clearance Pipe with elbows to the wall pass-through connector.
 - (a) Maintain 1/4" rise per foot (horizontal length) from the appliance to the chimney.
 - (b) Connect each section so the crimped end faces downward.
 - (c) Secure each section to each other using at least three (3) sheet metal screws or rivets.
 - (d) Use three (3) sheet metal screws to fasten DVL Close Clearance Pipe to New Buck Cast Collar on heater. after New Buck Cast Collar Part# MA6CHIMCNB has been attached to stove. (See Page 27 Figure 22).

**C. Rear exit Vertical then to Horizontal into Masonry Flue using
(6" DVL Close Clearance pipe ,and Elbows) .
With standard close clearance shield and pipe shield.
Model 261 minimum clearance to combustibles**

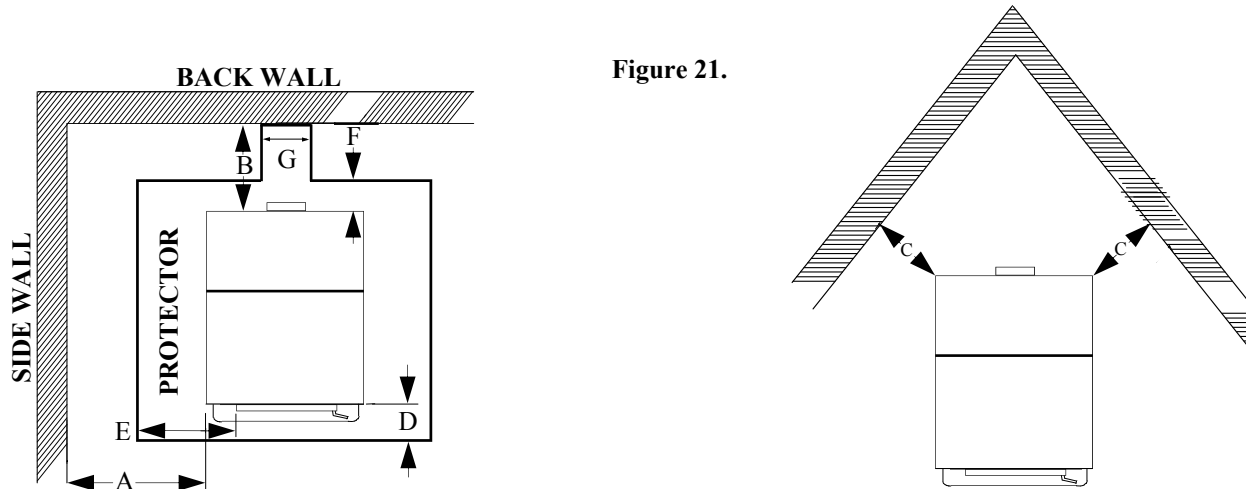

Figure 21.

A B C D E F G

MODEL 261 13" 13" 13" 20" 8" 3" 10"

NOTE: All clearances are to combustibles with all low clearance shields, and double wall pipe with elbows ,and minimum floor protector.
NOTE: Model 261 comes standard with low clearance shields.

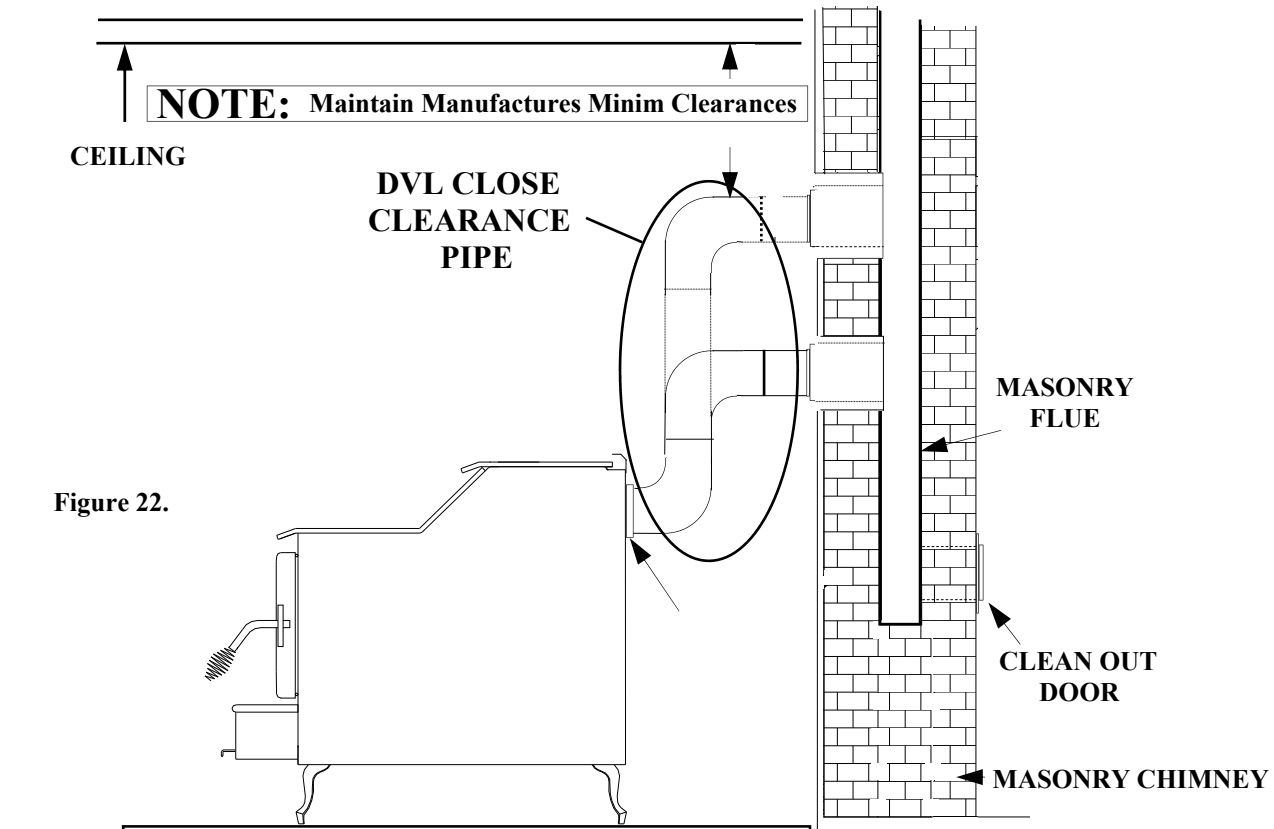

Figure 22.

D. Rear exit into Masonry Fireplace using (6" Single Wall pipe, minimum 24 ga. blued or black pipe) .

With standard close clearance shield and pipe shield

NOTE: For minimum clearances (See Figure 23).

INSTALLATION PREPARATION

1. Locate furniture and other materials away from the front of the fireplace to allow free access to the fireplace.
2. Thoroughly clean the fireplace or flue of ashes and soot.
3. Check the chimney and smoke chamber for excessive buildup of creosote or soot. Also, check for obstructions, such as bird's nests. If the chimney is excessively dirty, clean it, or have someone clean it professionally BEFORE installing or using the room heater.
4. If the fireplace has an ash dump or outside air provision, these must be sealed off with metal or tightly packed non-combustible insulation to prevent cold air from entering the fireplace chamber.
5. If top of rear flue exit with standard leg kit is above 24", **Note:**A 24" flue exit height may be achieved by using the optional 2" legs **Part# FA FS261** to bring the rear exit down to acceptable clearances
6. Remove or wire open the fire place damper.
7. A noncombustible sealing plate must be installed to close, and seal the opening of the fireplace. A hole diameter of the pipe used must be cut into the sealing plate to facilitate a place for the stove pipe to go thru into the fireplace flue.
Note, the pipe must go above the damper 2" to have proper flow. (See Page 29 Figure 24)
8. Once all codes are met, and stove is in proper location measure from back of stove to where the center of the flue is and cut pipe accordingly. Simply connect the Single Wall Pipe minimum 24 ga. blued or black pipe, per chimney manufacturers instructions.
 - (a) Maintain 1/4" rise per foot (horizontal length) from the appliance to the chimney.
 - (b) Connect each section so the crimped end faces towards stove.
 - (c) Secure each section to each other using at least three (3) sheet metal screws or rivets.
 - (d) Use three (3) sheet metal screws to fasten pipe to New Buck Cast Collar collar on heater.(See Page 21 Figure 16)

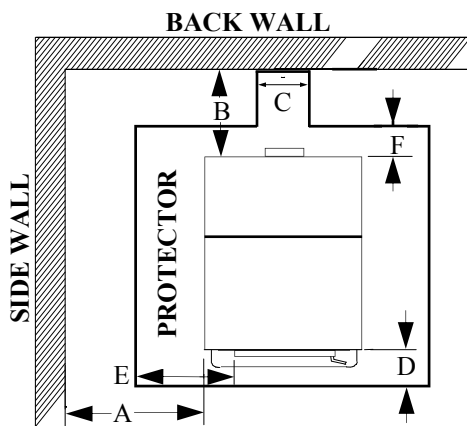

Figure 23.

NOTE: For minimum mantel height (See Page 29 Figure 24).

| | | | | | | |
|-----------|-----|-----|------|-----|----|----|
| | A | B | D | C | E | F |
| MODEL 261 | 13" | 13" | 20 " | 10" | 8" | 3" |

NOTE:All clearances are to combustibles with all low clearance shields, and single wall pipe with elbows ,and minimum floor protector.**NOTE:** Floor protector must extend length of horizontal flue pipe to wall. **NOTE:** Model 261 comes standard with low clearance shields.

**D. Rear exit in to Masonry Fireplace using
(6" single wall pipe, minimum 24 ga. blued or black) .
With standard close clearance shield and pipe shield**

NOTE: For minimum clearances (Page 29 Figure 23. also Figure 24).

NOTE: Optional 2" legs Part # FA FS261 Are available when installing Model 261 into a masonry fireplace with existing height of only 24".

WITH 2" LEGS, THE
TOP OF THE REAR
EXIT ON THE STOVE IS
BELOW 24" FROM
FLOOR OR HEARTH
ENABLING TO INSERT
PIPE INTO MOST
MASONRY FIREPLACE

Figure 24.

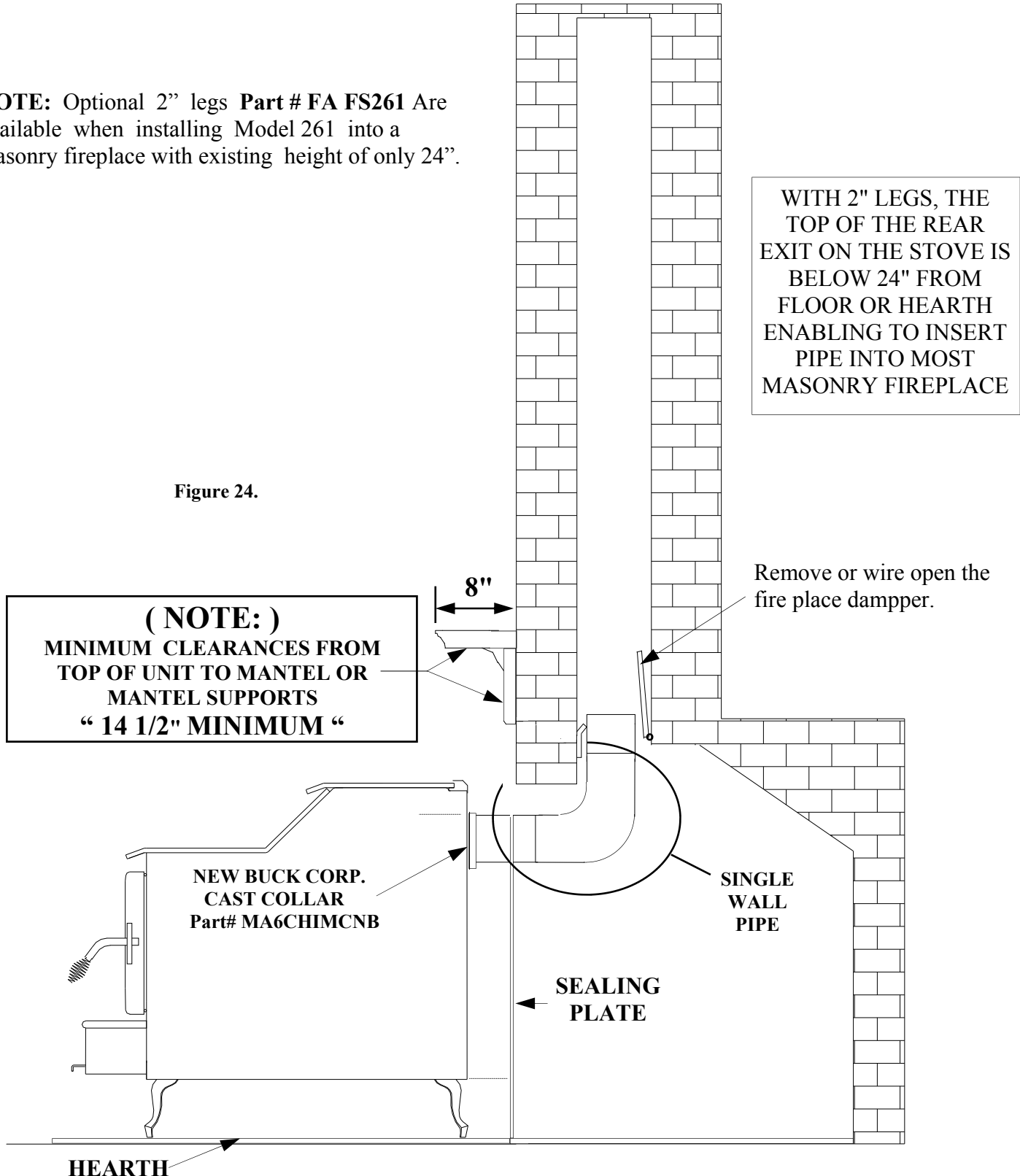

SECTION IV

Alcove Installation Vertical or Horizontal Exit

For optional Vertical exit or Horizontal exit installation locations refer back to table of contents Section IV

MINIMUM CLEARANCES TO FLOOR AND COMBUSTIBLES

See minimum floor protector measurements, and also for minimum clearances to combustibles

- A. vertical exit (Page 33, Figure 27 or Page 35, Figure 29) or
- B. rear exit (Page 37, Figure 31).

Floor Protection:

When installing freestanding heater, a floor protector must be used. Floor protection must be 3/8" minimum thickness non-combustible material or equivalent. R=0.06

How to use alternate materials and how to calculate equivalent thickness.

An easy means of determining if a proposed alternate floor protector meets requirements listed in the appliance manual is to follow this procedure:

1. Convert specification to R-value:
 - R-value is given—no conversion is needed.
 - K-factor is given with a required thickness (T) in inches:
C-factor is given: $R=1/C$
2. Determine the R-value of the proposed alternate floor protector.
 - Use the formula in step (1) to convert values not expressed as "R"
 - For multiple layers, add R-values of each layer to determine the overall R-value.
3. If the overall R-value of the system is greater than the R-value of the specified floor protector, the alternate is acceptable.

Example:

The specified floor protector should be 3/4" thick material with a K-factor of 0.84.

The proposed alternate is 4" brick with a C-factor of 1.25 over 1/8" mineral board with a K-factor of 0.29.

Step (a): Use formula above to convert specification to R-value. $R= 1/K \times T = 1/0.84 \times .75 = 0.893$

Step (b): Calculate R of proposed system. 4" brick of $C=1.25$, therefore $R_{brick} = 1/C = 1/1.25 = 0.80$ 1/8" mineral board of $K = 0.29$, therefore $R_{min.bd.} = 1/0.29 \times 0.125 = 0.431$

Step (c): Compare proposed system R of 1.231 to specified R of 0.893. Since proposed system R is greater than required, the system is acceptable.

Definitions:

$$\text{Thermal conductance} = C = \frac{\text{Btu}}{(\text{hr})(\text{ft}^2)(\text{°F})} = \frac{\text{W}}{(\text{m}^2)(\text{°K})}$$

$$\text{Thermal conductance} = K = \frac{(\text{Btu})(\text{inch})}{(\text{hr})(\text{ft}^2)(\text{°F})} = \frac{\text{W}}{(\text{m})(\text{°K})} = \frac{(\text{Btu})}{(\text{hr})(\text{ft})(\text{°F})}$$

$$\text{Thermal conductance} = R = \frac{(\text{ft}^2)(\text{hr})(\text{°F})}{\text{Btu}} = \frac{(\text{m}^2)(\text{°K})}{\text{W}}$$

Select an installation location that will give the best airflow from the front of the heater to the remainder of the home.

PREPARING THE STOVE FOR INSTALLATION

1. Inspect the unit for any obvious physical damage.
2. Plug the power cord into a 115V AC outlet to test the motor and fan when optional motor is being used. “Do not run power cord under unit or in high traffic areas”.
3. Check the primary air draft control to ensure that it slides freely.
4. Remove any items from within the firebox. Spread a dropcloth on the floor behind the heater. Next, tilt the heater so that the back is on the drop cloth.
5. Then obtain four legs, attach the legs to holes in bottom of unit with bolts and washers supplied with the leg kit. (See Figure 25).

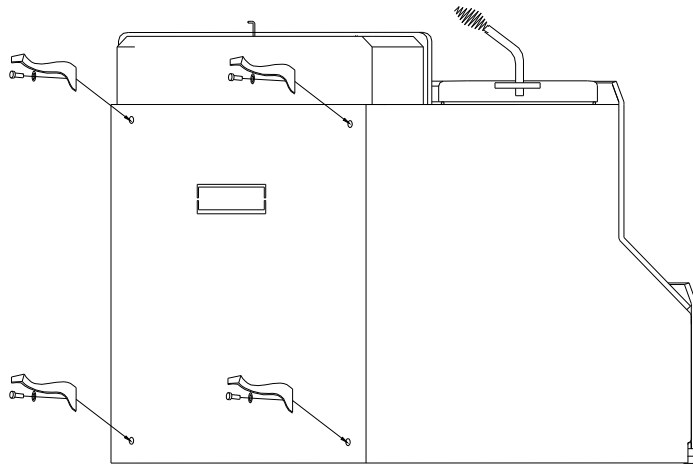

Figure 25.

6. Reposition the heater to the upright position.
7. Next fasten New Buck’s cast collar Part number MA6CHIMCNB to the flue exit of stove to be used, using the J hook’s provided. Position collar with gasket towards the unit, tighten the J hook’s **Firmly** . (See Figure 26).
8. Fasten New Buck’s Flue Collar Plate to the exit not used for burning stove. Firmly secure the Flue Collar Plate Bracket with the nut and washer provided .(See Figure 28).

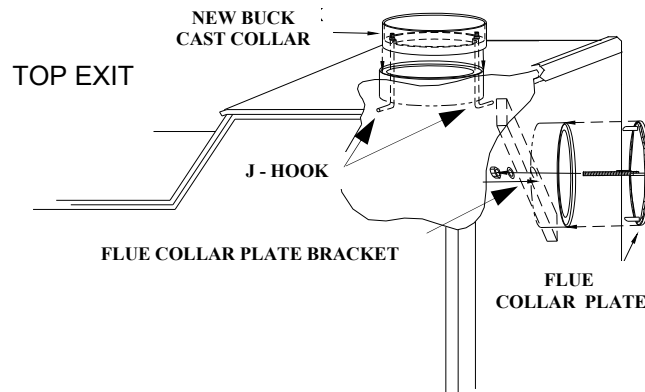

Figure 26.

9. Now the stove is ready to be positioned in the predetermined location.

A-1. Vertical Exit Installation

HOW TO LOCATE CHIMNEY EXIT, AND INSTALL

A-1. Vertical Exit using (6" DVL Close Clearance pipe, or Shielded Single wall pipe, and any Listed 2100° UL 103 HT chimney).

With standard close clearance shield and pipe shield.

NOTE: For minimum clearances (See Page 33, Figure 27).

1. Suspend a plumb bob from the ceiling above the unit so that the weight is hanging in the center of the flue exit. (A small weight on a string will serve as a plumb bob.) Mark the ceiling where the string is suspended to locate the center of the chimney hole.
2. After locating the center of the hole, install the ceiling support box, chimney or chimney connector, flashing, and rain cap per the chimney manufacturer's instructions, and local building codes for installation through combustible walls or ceilings.
3. Now connect the stove and ceiling support box using DVL close clearance pipe or Shielded Single wall pipe. Connect each section per manufacturer's instructions, and secure each section to each other using minim (3) sheet metal screws or rivets. DVL close clearance pipe or Shielded Single wall pipe is to be connected with (3) sheet metal screws or rivets to New Buck Corporation Cast Collar, after New Buck Cast Collar Connector has been attached to stove. (**See Page 33, Figure 38**).

ALCOVE INSTALLATION AND CLEARANCES

A-1. Alcove Vertical exit using (6" DVL Close Clearance pipe, and any listed 2100° UL 103 HT. TYPE Chimney).

With standard close clearance shield and pipe shield.

Model 261 minimum clearance to combustibles.

Figure 27

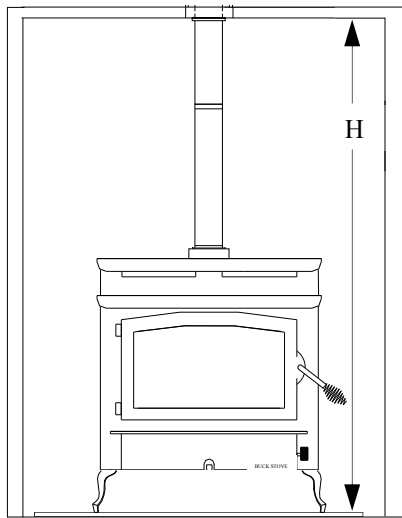
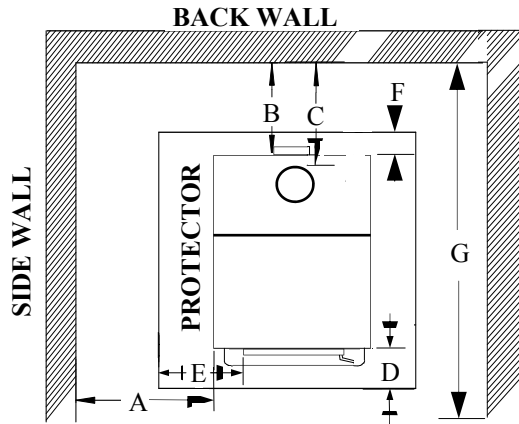

A B C D E F G H

MODEL 261 14" 4" 7" 20" 8" 3" 47" 84"

Figure 28

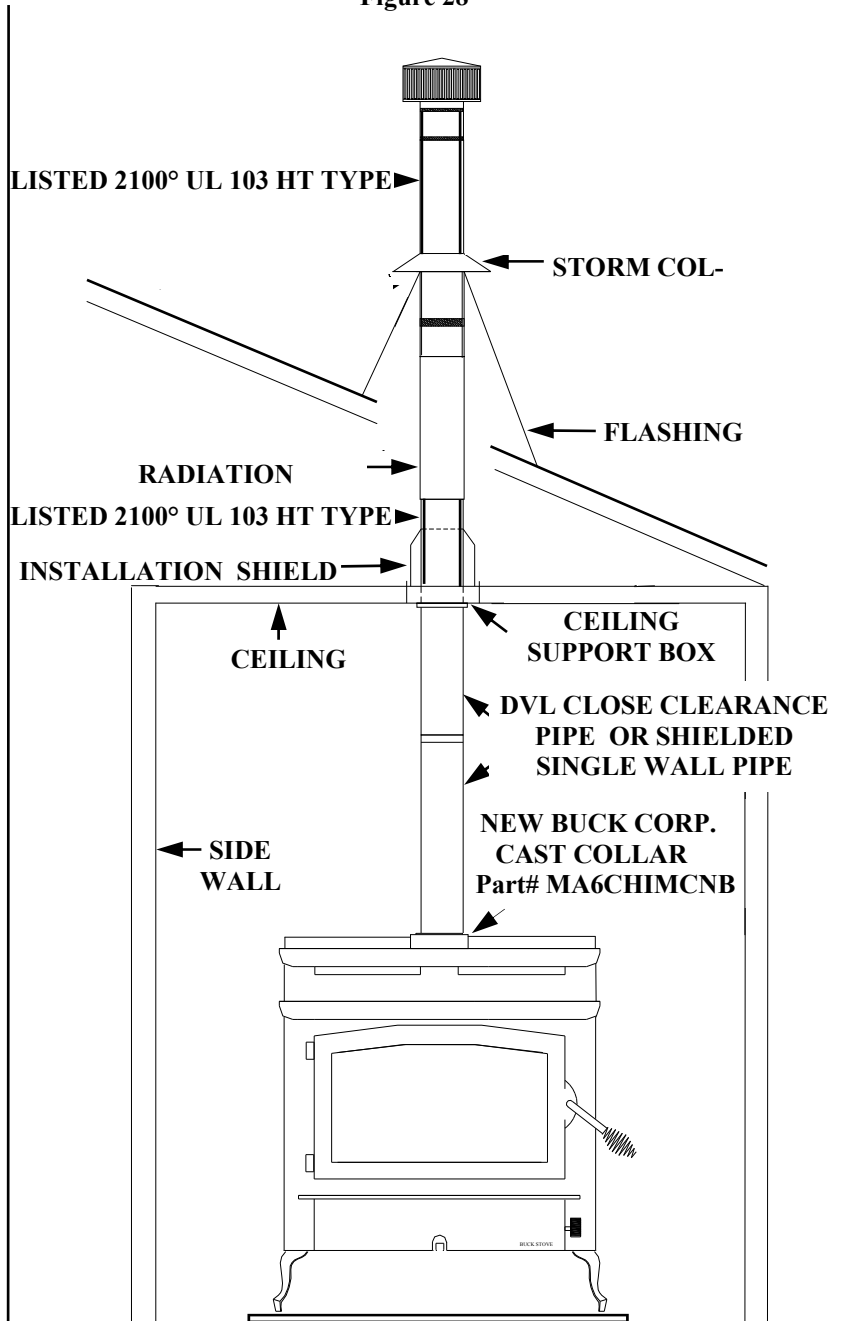

NOTE: All clearances are to combustibles with all low clearance shields and double wall pipe , and minimum floor protector.

NOTE: Model 261 comes standard with low clearance shields.

A-2. Vertical Exit Installation

HOW TO LOCATE CHIMNEY EXIT, AND INSTALL

**A-2. Vertical Wall Exit using (6" DVL Close Clearance Pipe and Elbow and any Listed 2100° UL HT chimney, and Listed 2100° UL HT T-Box assembly).
With standard close clearance shield and pipe shield**

NOTE: For minimum clearances (See Page 35, Figure 29).

1. Mark the plumb line on the wall directly behind the center of the heater.
(See Page 35, Figure 30.)

NOTE: When using DVL Close Clearance Pipe , **“maintain manufacturers minimum clearances”** between pipe and ceiling.

2. Place the vertical portion of the heater pipe and the elbow in position and project a point onto the plumb line level with the center of the elbow.
3. Measure up so there will be at least 1/4" rise per foot of horizontal connector pipe, maintaining clearances to the ceiling as noted in (Page 35, Figure 29, and Figure 30). This will give you the center of the hole for the chimney penetration.
4. After locating the center of the penetration, install the tee-box and chimney as per the chimney manufacturer's specifications.
5. Connect the DVL close clearance pipe to the tee-box per manufacturer's instructions,. DVL close clearance pipe is to be connected with (3) sheet metal screws or rivets to New Buck Corporation Cast Collar, after New Buck Cast Collar Connector has been attached to stove. (See Page 35 ,Figure 30.).

ALCOVE INSTALLATION AND CLEARANCES

**A-2. Alcove Vertical Wall exit using (6" DVL Close Clearance pipe, Elbow and any listed 2100° UL 103 HT. TYPE Chimney).
With standard close clearance shield and pipe shield.
Model 261 minimum clearance to combustibles.**

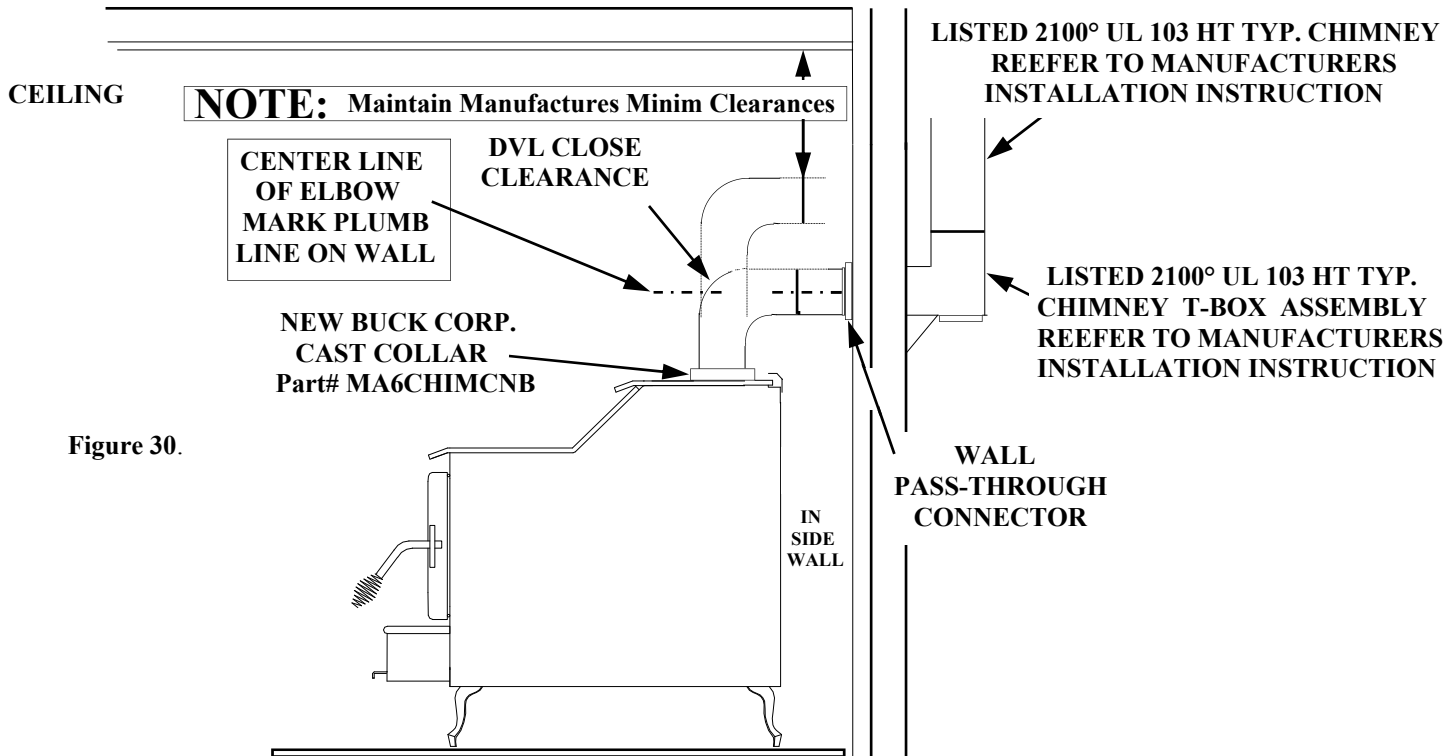
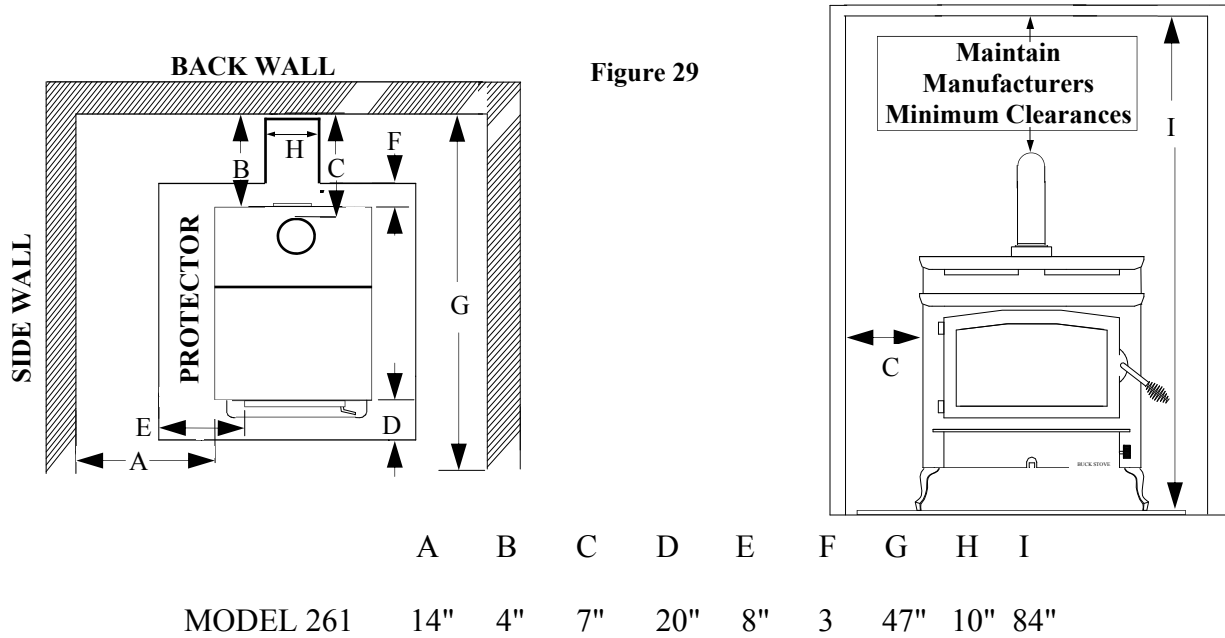

NOTE: All clearances are to combustibles with all low clearance shields and double wall pipe, and minimum floor protector. **NOTE:** Floor protector must extend length of horizontal flue pipe to wall. **NOTE:** Model 261 comes standard with low clearance shields.

B-1. Rear Exit Installation

HOW TO LOCATE CHIMNEY EXIT, AND INSTALL

**B-1. Vertical Rear Exit using (6" DVL Close Clearance Pipe and any Listed 2100° UL HT chimney, and Listed 2100° UL HT T-Box assembly).
With standard close clearance shield and pipe shield
NOTE: For minimum clearances (See Page 37, Figure 31).**

1. Measure up so there will be at least 1/4" rise per foot of horizontal connector pipe, maintaining clearances as noted in (Page 37, Figure 31). This will give you the center of the hole for the chimney penetration.
2. After locating the center of the penetration, install the tee-box and chimney as per the chimney manufacturer's specifications.
3. Connect the DVL close clearance pipe to the tee-box per manufacturer's instructions,. DVL close clearance pipe is to be connected with (3) sheet metal screws or rivets to New Buck Cast Collar, after New Buck Cast Collar has been attached to stove. (See Page 37 ,Figure 32.).

ALCOVE INSTALLATION AND CLEARANCES

B-1. Alcove Rear exit using (6" DVL Close Clearance pipe, and any listed 2100° UL 103 HT TYPE Chimney).

With standard close clearance shield and pipe shield.

Model 261 minimum clearance to combustibles.

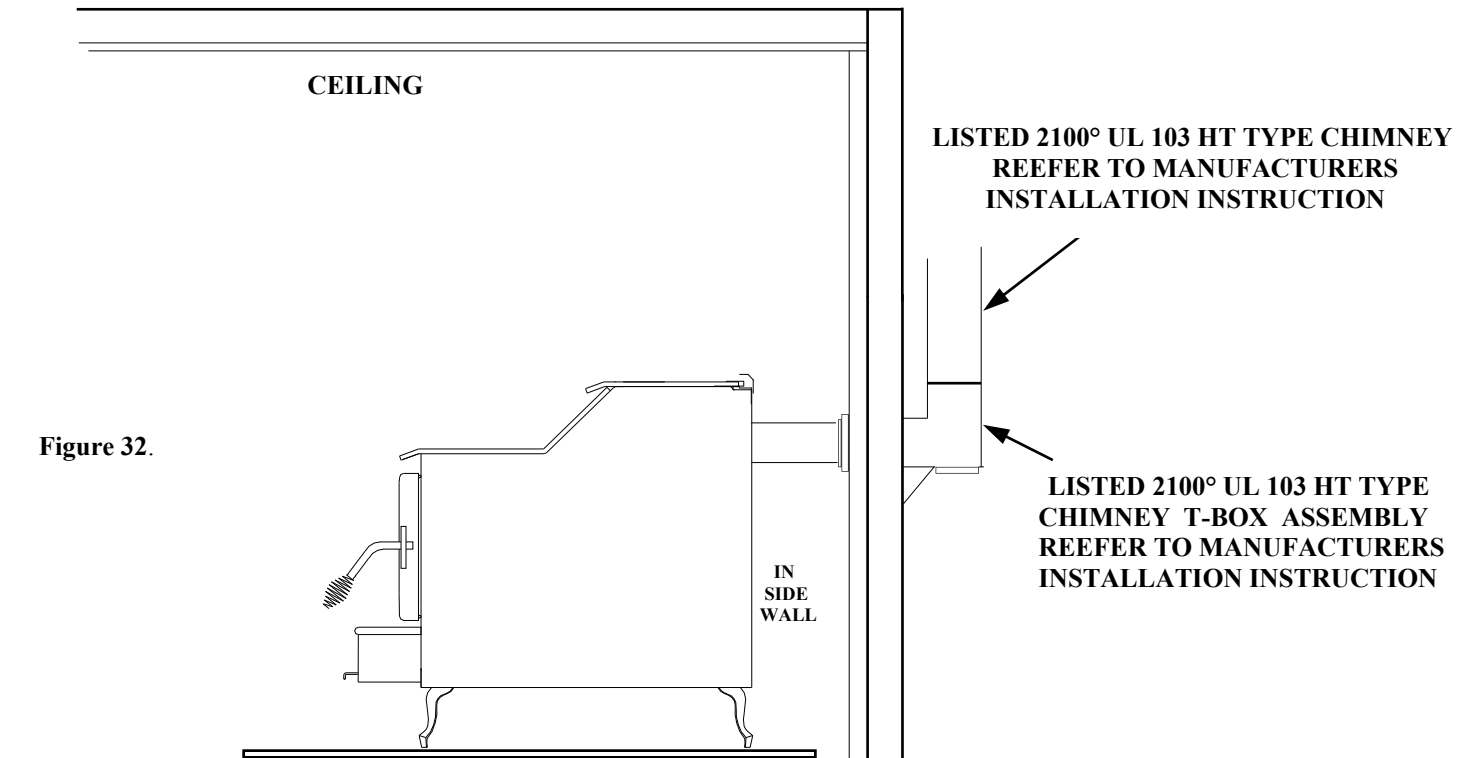
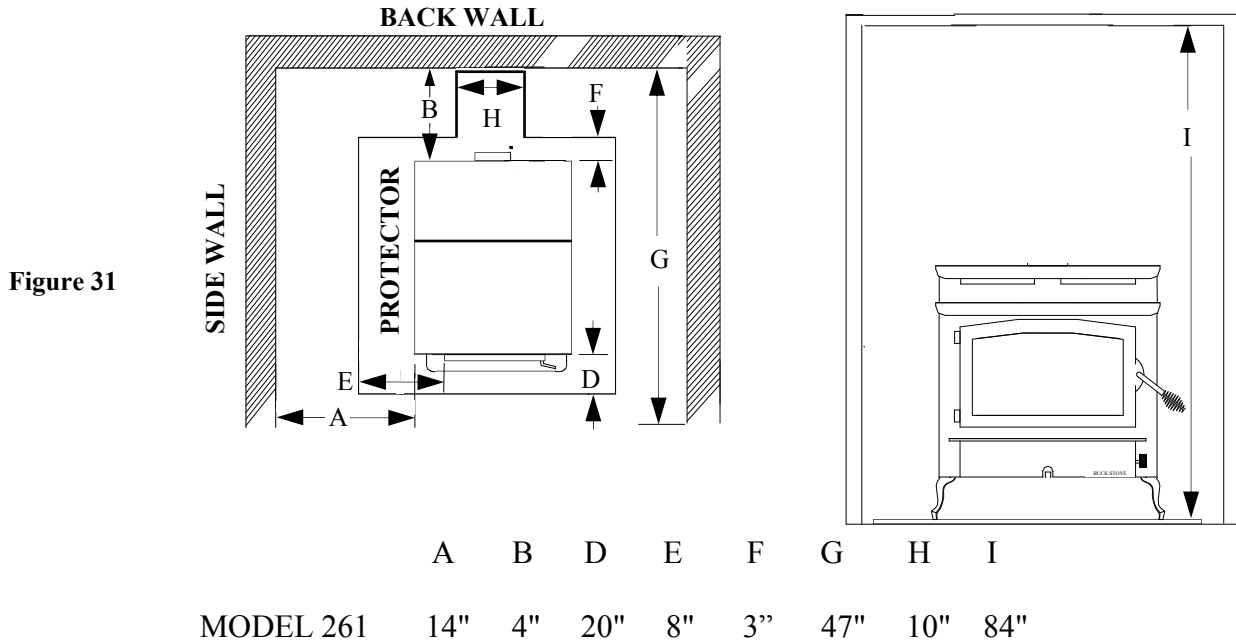

NOTE: All clearances are to combustibles with all low clearance shields and double wall pipe, and minimum floor protector. **NOTE:** Floor protector must extend length of horizontal flue pipe to wall. **NOTE:** Model 261 comes standard with low clearance shields.

FINAL CHECK

1. Recheck the specified clearances.
2. Remove all foreign material from the firebox area.
3. Open the primary air draft.
4. Plug the power cord into a 115V AC outlet when using with optional motor.
5. Place crumpled pieces of newspaper in the stove. Light it and close the doors. Ensure that the stove draws properly through the primary draft.
6. Check for smoke leaks around the door.

CAUTION

Open the doors and check for smoke escaping from the front of the stove. Smoking usually indicates a defective or poorly positioned chimney. Some chimneys with a marginal draft can be preheated by lighting newspaper and holding it near the open damper with a poker or fire tong. Once the chimney heats up, a proper draft can usually be obtained.

If a thorough review of the Troubleshooting Guide in the rear of the manual does not reveal the problem, contact your dealer for assistance.

CAUTION

The unit is painted with a specially formulated high temperature paint that cures during the first two or three firings. You may notice a slight smoking effect and an odor of burning paint when you build the first fires. This is normal and is not a cause for alarm. In some cases, these fumes will activate a smoke alarm. Opening a window near the unit will allow these fumes to escape. DO NOT build a large, roaring fire until this curing is complete or the heater finish may be damaged.

SECTION V

FREESTANDING MOBILE HOME INSTALLATION

MINIMUM CLEARANCES TO FLOOR AND COMBUSTIBLES

See minimum floor protector measurements, and also for minimum clearances to combustibles (See Page 42, Figure 35).

Floor Protection:

When installing freestanding heater, a floor protector must be use. Floor protection must be 3/8” minimum thickness non-combustible material or equivalent.

How to use alternate materials and how to calculate equivalent thickness.

An easy means of determining if a proposed alternate floor protector meets requirements listed in the appliance manual is to follow this procedure:

1. Convert specification to R-value:
 - R-value is given—no conversion is needed.
 - K- factor is given with a required thickness (T) in inches:
 - C-factor is given: $R=1/C$
2. Determine the R-value of the proposed alternate floor protector.
 - Use the formula in step (1) to convert values not expressed as “R”
 - For multiple layers, add R-values of each layer to determine the overall R-value.
3. If the overall R-value of the system is grater than the R-value of the specified floor protector, the alternate is acceptable.

Example:

The specified floor protector should be 3/4” thick material with a K-factor of 0.84.

The proposed alternate is 4” brick with a C-factor of 1.25 over 1/8” mineral board with a K-factor of 0.29.

Step (a): Use formula above to convert specification to R-value. $R= 1/K \times T = 1/0.84 \times .75 = 0.893$

Step (b): Calculate R of proposed system. 4” brick of $C=1.25$, therefore $R_{brick} = 1/C = 1/1.25 = 0.80$ 1/8” mineral board of $K = 0.29$, therefore $R_{min.bd.} = 1/0.29 \times 0.125 = 0.431$

Step (c): Compare proposed system R of 1.231 to specified R of 0.893. Since proposed system R is greater than required , the system is acceptable.

Definitions:

$$\text{Thermal conductance} = C = \frac{\text{Btu}}{(\text{hr})(\text{ft}^2)(\text{°F})} = \frac{\text{W}}{(\text{m}^2)(\text{°K})}$$

$$\text{Thermal conductance} = K = \frac{(\text{Btu})(\text{inch})}{(\text{hr})(\text{ft}^2)(\text{°f})} = \frac{\text{W}}{(\text{m})(\text{°K})} = \frac{(\text{Btu})}{(\text{hr})(\text{tf})(\text{°F})}$$

$$\text{Thermal conductance} = R = \frac{(\text{ft}^2)(\text{hr})(\text{°F})}{\text{Btu}} = \frac{(\text{m}^2)(\text{°K})}{\text{W}}$$

Select an installation location that will give the best airflow from the front of the heater to the remainder of the home.

PREPARING THE STOVE FOR INSTALLATION

1. Inspect the unit for any obvious physical damage.
2. Plug the power cord into a 115V AC outlet to test the motor and fan when optional motor is being used. "Do not run power cord under unit or in high traffic areas".
3. Check the primary air draft control to ensure that it slides freely.
4. Remove any items from within the firebox. Spread a dropcloth on the floor behind the heater. Next, tilt the heater so that the back is on the drop cloth.
5. Then obtain four legs, attach the legs to holes in bottom of unit with bolts and washers supplied with the leg kit. (See Figure 35).

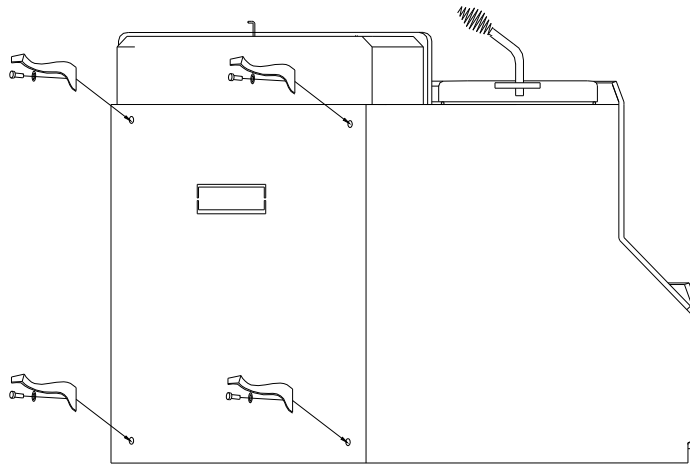

Figure 33.

6. Reposition the heater to the upright position.
7. Next fasten New Buck's Cast Collar Part number MA6CHIMCNB to the flue exit of stove to be used, using the J hook's provided. Position collar with gasket towards the unit, tighten the J hook's **Firmly** secured. (See Figure 36).
8. Fasten New Buck's Flue Collar Plate to the exit not used for burning stove. Firmly secure the Flue Collar Plate Bracket with the nut and washer provided. (See Figure 36).

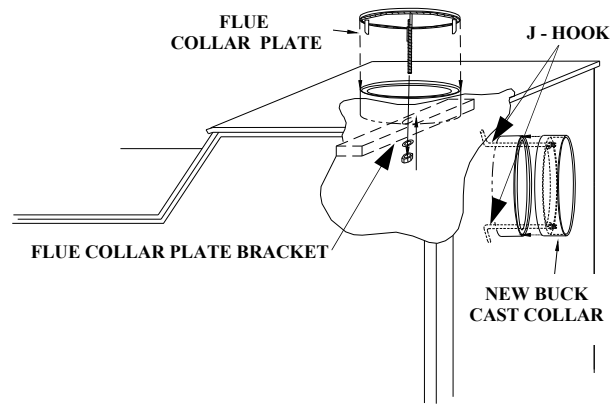

Figure 34.

9. Now the stove is ready to be positioned in the predetermined location.

FREESTANDING MOBILE HOME INSTALLATION

PREPARING THE ROOM HEATER LOCATION

1. Select an installation location that will give the best airflow from the front of the heater to the remainder of the home. (See Page 42 Figure 35 minimum clearances to combustibles).

CAUTION

THE STRUCTURAL INTEGRITY OF THE MOBILE HOME FLOOR MUST BE MAINTAINED. (MOVE OPENING AND/OR REPOSITION HEATER LOCATION IF NECESSARY).

When installing model 261 into mobile home, heater must be secure to the structure of mobile home.

Install in accordance with 24CFR, Part 3280 (HUD).

2. Place the protective floor pad in position. (See Page 42, Figure 35 For Clearances.)
3. Place the unit on the pad making sure the minimum clearance specifications are met.

This model is designed for connection to: any Listed 6" 2100° UL 103 HT. TYPE chimney also any Listed 6" UL DVL Close Clearance Pipe. Follow pipe manufacturers instructions carefully.

This room heater must be converted to (1) a chimney complying with the requirements for Type HT chimneys in the Standard for Chimneys, Factory-Built, Residential, Type and Building Heating Appliance, UL 103, or (2) a code approved masonry chimney with a flue liner.



CAUTION: Certain installation types require the use of certain chimney types. Please follow these instructions exactly.

4. Lightly mark with a pencil, the location of the legs on the protective pad.
NOTE: Position heater out of the way of the installation area. Lay the heater on it side. The following must be done. Locate optional air inlet plate opening on outer bottom of unit. With pliers or screwdriver, pry ,or twist out tab till it breaks loose. This is where your outside air enters unit after installation is complete. (see Page 43 Figure 36).
5. Obtain the outside air duct from the box, Part# MA 70075-01 Measure from center of front feet back to center of air inlet, and from center of side legs to center of air inlet, Use these measurements to center and mark the placement of the out side air duct. Pre-drill (4) 1/8" holes into the bottom of the heater to attach outside air duct to the heater with screws provided, attach, test fit, and temporarily leave the outside air duct on the bottom of the heater.
6. Measure the location of the outside air duct that's temporarily attached to heater using the legs feet for reference measuring points to find the center of out side air duct. Use these measurements to mark the center location of the out side air duct onto the protective pad. (see Page 43 Figure 37). **Note:** Be sure to measure one more time for floor joist , and or obstacles beneath floor where hole is to be cut.
7. Now mark the outside air duct opening, on to the pad. Cut a 4-1/4" diameter hole in the pad and continue through the floor.
8. Remove outside air duct from the heater. Slide the outside air duct through the hole in the pad, and floor.

9. Now, reposition the heater on the pad being sure to line the feet up with the reference marks.
 10. Slide the outside air duct up to the bottom of the heater and attach it with the screws supplied with the kit, using a wrench or ratchet. (See Page 43 Figure 38)
- Note:** If the mobile home is underpinned you must provide extra pipe (NOT INCLUDED IN PACKAGE) to extend outside air ducting through underpinning or foundation of mobile home. The inlet of the outside air duct must be in the same atmospheric as pressure the exhaust. (See Page 43 Figure 38).

**Vertical exit using (6" DVL Close Clearance pipe, and any listed 2100° UL 103 HT. TYPE Chimney).
With standard close clearance shield and pipe shield.
Model 261 minimum clearance to combustibles.**

FREESTANDING MOBILE HOME INSTALLATION

Figure 35.

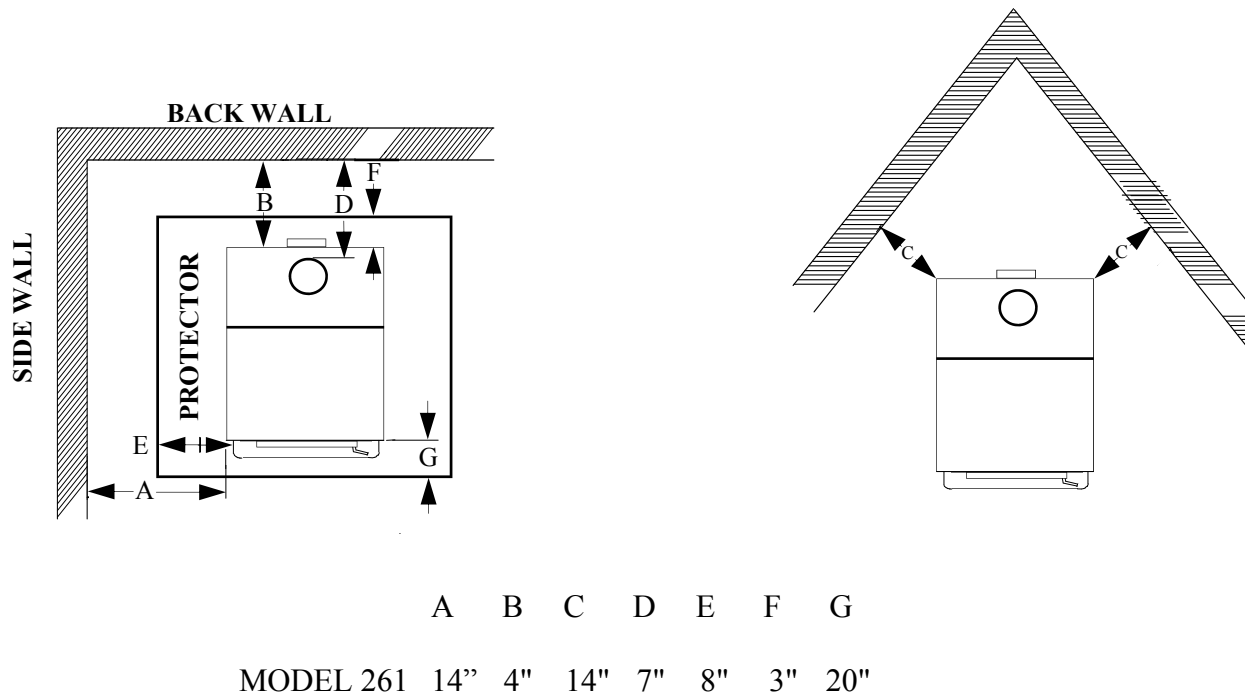

NOTE: All clearances are to combustibles with all low clearance shields and double wall pipe or shielded single wall pipe and minimum floor protector.

NOTE: Model 261 comes standard with low clearance shields.

Optional air inlet plate opening on outer bottom of unit.

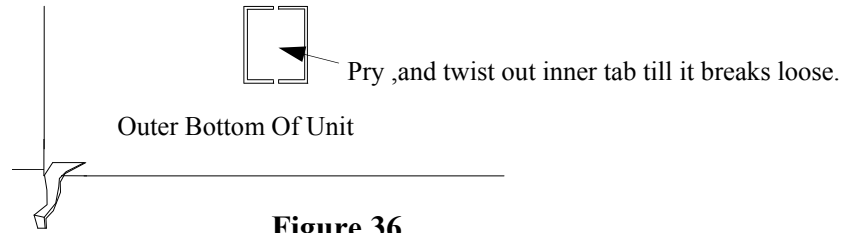

Figure 36

Take measurements from bottom of heater, and use them to locate the opening for the out side air duct, place them onto protective pad.

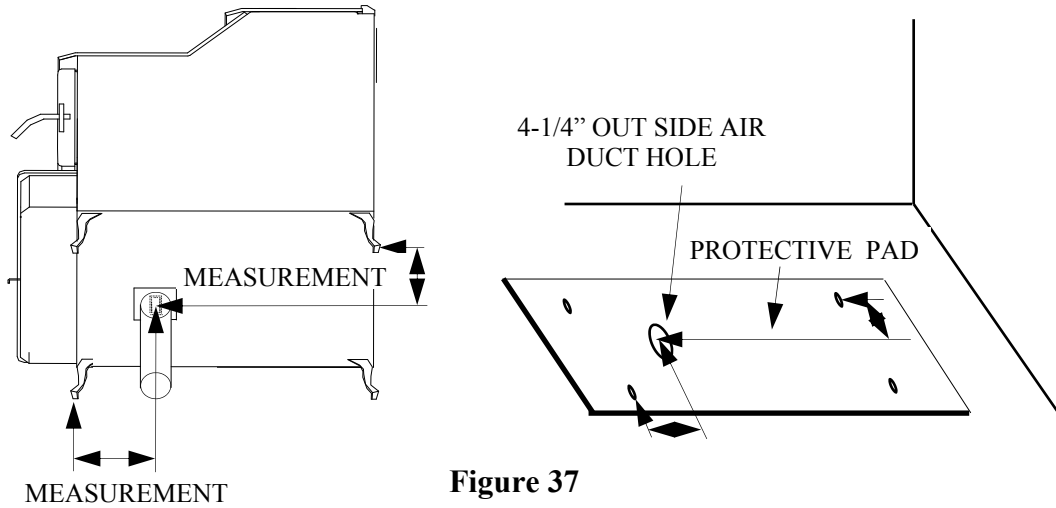

Figure 37

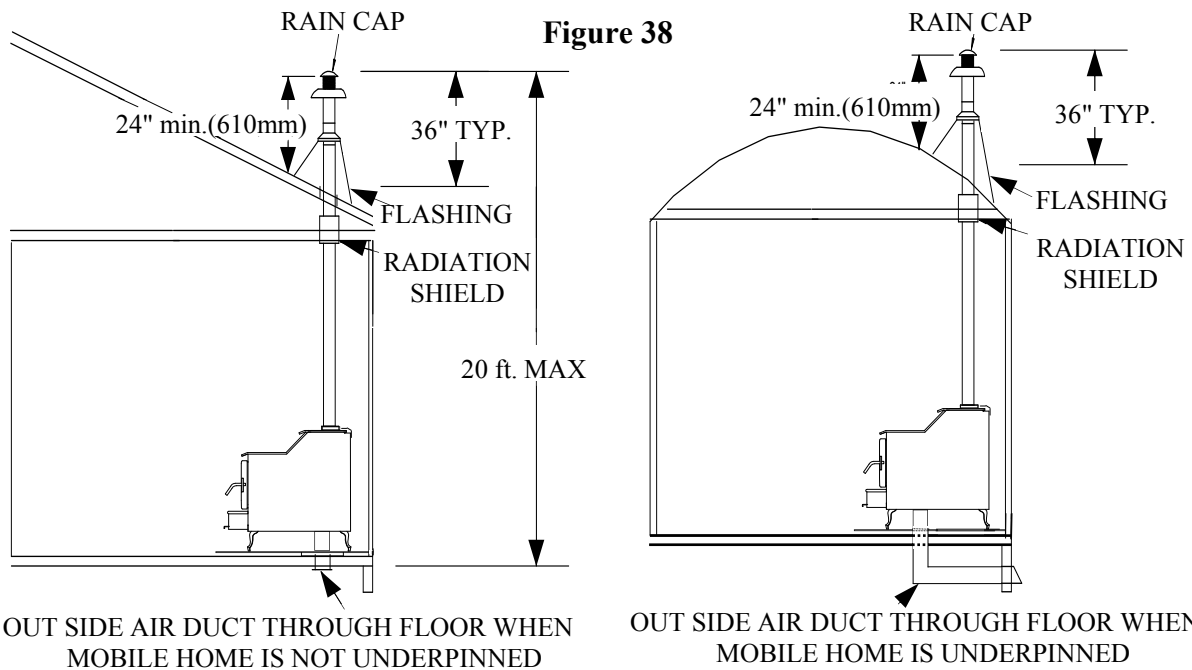

Figure 38

OUT SIDE AIR DUCT THROUGH FLOOR WHEN MOBILE HOME IS NOT UNDERPINNED

OUT SIDE AIR DUCT THROUGH FLOOR WHEN MOBILE HOME IS UNDERPINNED

HOW TO LOCATE CHIMNEY EXIT, AND INSTALL Ceiling Exit (Using Close Clearance listed chimney)

1. Suspend a plumb bob from the ceiling above the unit so that the weight is hanging in the center of the flue exit. (A small weight on a string will serve as a plumb bob.) Mark the ceiling where the string is suspended to locate the center of the chimney hole.

2. After locating the center of the hole install the ceiling support box, chimney, flashing and rain cap using listed chimney only. Only use pipe listed in this manual.

CAUTION

REFER TO CHIMNEY MANUFACTURER'S INSTRUCTIONS FOR ASSEMBLY AND DISASSEMBLY OF CHIMNEY PARTS. BE SURE TO FOLLOW CHIMNEY INSTRUCTIONS FOR PROPER CLEARANCES TO COMBUSTIBLE AND PROPER AIR SPACING REQUIRED.

3. Add additional pipe until both of the following are met:
 - (a) Chimney pipe is 3 feet higher than roof at the point where it penetrates the roof.
 - (b) Chimney pipe height is at least 2 feet higher than any part of the roof within 10 feet of the chimney. (See Page 43 Figure 38.)
4. Next, install a New Buck Cast Collar Part # MA6CHIMCNB to the flue of the heater. (See Page 40 Figure 34).
5. Using double wall chimney connector, connect the heater to the chimney by following manufacturer's installation instructions exactly. (See Figure 39.)

Figure 39.

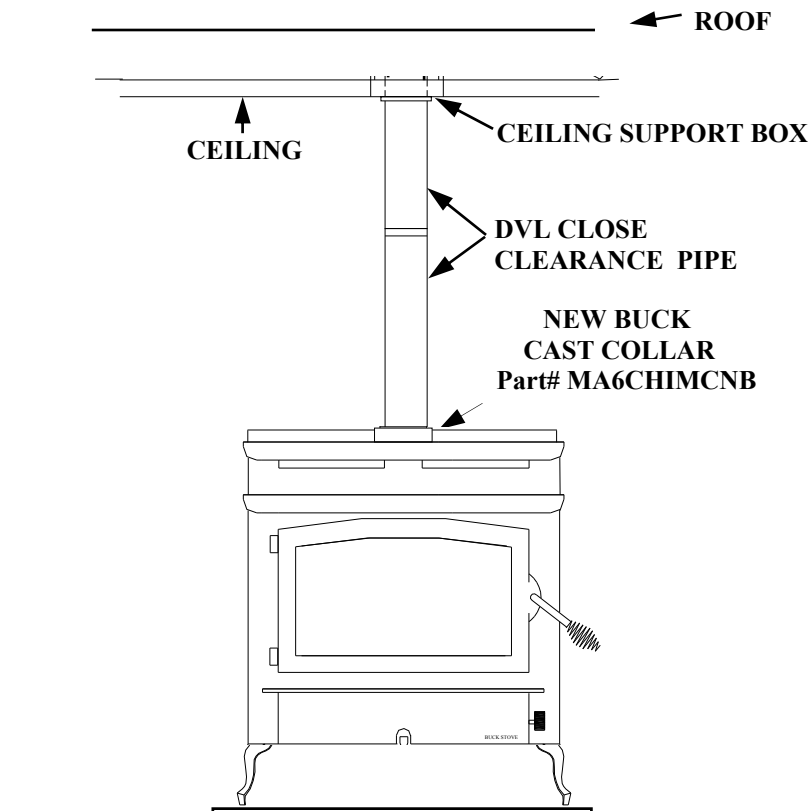

FINAL CHECK

1. Recheck the specified clearances.
2. Remove all foreign material from the firebox area.
3. Open the primary air draft.
4. Plug the power cord into a 115V AC outlet when using with optional motor.
5. Place crumpled pieces of newspaper in the stove. Light it and close the doors. Ensure that the stove draws properly through the primary draft.
6. Check for smoke leaks around the doors.
7. Open the doors and check for smoke escaping from the front of the stove. Smoking usually indicates a defective or poorly positioned chimney. Some chimneys with a marginal draft can be preheated by lighting newspaper and holding it near the open damper with a poker or fire tong. Once the chimney heats up, a proper draft can usually be obtained.

If a thorough review of the Troubleshooting Guide in the rear of the manual does not reveal the problem, contact your dealer for assistance.

CAUTION

THE UNIT IS PAINTED WITH A SPECIALLY FORMULATED HIGH TEMPERATURE PAINT THAT CURES DURING THE FIRST TWO OR THREE FIRINGS. YOU MAY NOTICE A SLIGHT SMOKING EFFECT AND AN ODOR OF BURNING PAINT WHEN YOU BUILD THE FIRST FIRES. THIS IS NORMAL AND IS NOT A CAUSE FOR ALARM. IN SOME CASES, THESE FUMES WILL ACTIVATE A SMOKE ALARM. OPENING A WINDOW NEAR THE UNIT WILL ALLOW THESE FUMES TO ESCAPE. DO NOT BUILD A LARGE ROARING FIRE UNTIL THIS CURING PROCESS IS COMPLETE OR THE HEATER FINISH MAY BE DAMAGED.

SECTION VI

WOOD HEATER SAFETY

Certain safety hazards are inherent in any wood heater installation. You should be aware of these so that a safe and proper installation can be made.

1. **FAULTY CHIMNEY:** An older masonry chimney should be thoroughly checked to be sure there are no holes or weak spots which could allow sparks or hot gases to escape.
2. **HEAT CONDUCTION:** Placing combustible materials too close to a heater or chimney can be a fire hazard.

By keeping these particular hazards in mind as you install and use your room heater you can ensure a safe, reliable installation.

The chimney and chimney connector should be inspected once every two months. Any build-up of soot should be removed to prevent the risk of a chimney fire. To remove chimney or chimney connector: Remove screws or fasteners. Remove pipe and clean with steel brush. Replace chimney or chimney connector, and replace screws and/or fasteners.

CAUTION

NEVER USE GASOLINE, GASOLINE TYPE LANTERN FUEL, KEROSENE, CHARCOAL LIGHTER FLUID OR SIMILAR LIQUIDS TO START OR "FRESHEN UP" A FIRE IN THE HEATER. KEEP ALL SUCH LIQUIDS WELL AWAY FROM THE STOVE WHEN IT IS IN USE. ALL FLUIDS OF THIS TYPE GIVE OFF VOLATILE FUMES AND CAN AND WILL EXPLODE!! DON'T TAKE A CHANCE WITH THE SAFETY OF YOUR HOME AND FAMILY.

DISPOSAL OF ASHES: Ashes should be placed in a metal container with a tight fitting lid. The closed container of ashes should be placed on a non-combustible floor or on the ground, well away from all combustible materials pending final disposal. If the ashes are disposed of by burial in soil or otherwise locally dispersed, they should be retained in the closed container until all cinders have thoroughly cooled.

CREOSOTE-FORMATION AND NEED FOR REMOVAL: When wood is burned slowly, it produces tar and other organic vapors, which combine with expelled moisture to form creosote. The creosote vapors condense in the relatively cool chimney flue of a slow-burning fire. As a result, creosote residue accumulates on the flue lining. When ignited this creosote makes an extremely hot fire.

SECTION VII OPERATION

This section of the manual is to help you get the maximum efficiency and maximum smoke (particulate) reduction from your heater. If you should experience any difficulty or have any questions concerning your heater, contact your dealer for assistance. **NOTE: The manufacturer recommends that for maximum performance burn natural seasoned hard wood.**

Build a fire for maximum efficiency. These models burn wood and extract heat so efficiently, a large fire is not necessary. A large fire not only wastes energy, it usually results in the home being too warm for comfort.

The following steps will serve as a guide for operating your stove.

BUILDING A FIRE

1. Open the door.
2. Open the primary air control under hearth, push in. To close pull all the way out.
3. Twist two pieces of non-colored newspaper into a roll and place them on the floor of the firebox.

NOTE: “ Do not use grate or elevate fire. Build wood fire directly on hearth.”

4. These models are not designed for the use of grates, andirons or other methods of supporting the fuel.
5. Lay several pieces of dry kindling on top of the newspaper.
6. Place three or four small pieces of firewood, 2-3" in diameter, on top of the kindling.
7. Light the newspaper in the front. Close and latch the door. Don't leave the fire unattended at this point. The draft system of the heater should start quickly. It may be necessary to preheat the chimney to get the draft started. To do this, open the door and add newspaper to the top rear of the wood. Light or let this paper ignite and allow to burn while holding the door slightly cracked. Once the draft has started, close and lock the door. You are over heating the unit if the chimney and or connector glows red.

8. **NOTE: After embers and a coal bed have been established, load the heater with seasoned natural hard wood, placing it length way front to rear.**

NOTE: THE FUELING DOOR MUST REMAIN CLOSED DURING OPERATION.

NOTE: If the optional blower is being used on the Model 261 Non-CatYour stove is Equipped with a automatic thermostat. When the stove gets hot enough, the thermostat will activate the room air blower. Set fan speed according to desired heat output.

NOTE: When refueling or removing ashes turn “OFF” room air blower. Be sure to turn room air blower back on when finished.

NOTE: Do not run power cord underneath heater, or in walk way or heavy traffic areas.

SECTION VIII TROUBLESHOOTING

PROBLEM

1. Sluggish Heater

POSSIBLE CAUSE

1. Obstruction in Chimney
2. Improperly sealed trim kit or direct connect kit
3. Manual damper in chimney is closed
4. Wet or unseasoned wood being burned
5. Poor chimney draft

SOLUTION

1. Check for and remove obstruction
2. (a) Check trim kit gasketing seal to fireplace and gasket as necessary to seal unit. Gasket under front bottom of stove if needed. (b) Check seal if using direct connect and correct.
3. Open manual damper and wire shut with stainless steel wire or remove damper
4. Burn dry seasoned wood
5. Improper chimney height or wrong size flue is being used. Cooler temperatures caused by external chimney.

| PROBLEM | POSSIBLE CAUSE | SOLUTION |
|---|--|---|
| 2. High fuel consumption | 1. Improper regulation of draft or inlet air | 1. (a) Close inlet air control as much as possible to maintain desired heat output. (b) Check gaskets, reinstall fiberglass gasketing round doors and glass as necessary |
| | 2. Improper door fitting | 2. Check door gasket, check adjustment of door latch |
| 3. Backpuffing | 1. Gusts of Wind | 1. (a) Smoke shelf in chimney is filled with creosote & ash (b) Chimney may need wind diverter. Raise chimney for better draft. |
| 4. Smoke rollout when heater door is opened | 1. Wind gusts blowing down the chimney | 1. (a) Smoke shelf in chimney is filled with creosote & ash (b) Chimney may need wind diverter. Raise chimney for better draft. |
| | 2. Opening heater door too fast | 2. Crack door for 15 seconds before fully opening door. |

NEW BUCK CORPORATION (NBC)
"LIMITED WARRANTY" FOR THE BUCK STOVE
PLEASE READ THIS WARRANTY CAREFULLY

PRODUCTS COVERED

This warranty covers the New Buck Stove heating unit, so long as it is owned by the original purchaser, including optional and standard accessories purchased at the same time, subject to terms, limitations, and conditions herein set out.

PRODUCTS NOT COVERED

This warranty does not cover the following:

- Glass;
- Refractory material such as refractory cement or firebrick;
- Gaskets.

This Warranty will also not cover any damage and/or failure caused by abuse or improper installation of the products covered.

WARRANTY TIME PERIODS

(A) Period I

For one year from the date of purchase, NBC will replace or repair, at its option, any part defective in materials or workmanship. The costs of parts only are included. The customer pays any labor or transportation charges required.

Thereafter

B) Period II

For the period after the first year from the date of purchase and extending for 5 years as long as the Buck Stove is owned by the original purchaser, NBC will repair or replace, at its option, any part defective in materials or workmanship, with the exception of: electrical motors, wiring, switches, and components: optional and standard accessories; and all parts not permanently attached to the heating unit. Parts not permanently attached to the heating unit are defined as those items designed to be removed from the stove, including those removable with common hand tools. The costs of parts only are included. The customer pays any labor or transportation charges required.

PROCEDURE

Should you feel that your BUCK STOVE is defective, you should contact any Buck Stove dealer for the name of your nearest authorized Buck Stove service representative, who will instruct you on the proper procedure, depending on which Warranty Time Period (Period I or Period II) applies.

If for any reason you are dissatisfied with the suggested procedures, you may contact us in writing at:

New Buck Corporation
Customer Service Department
P. O. Box 69
Spruce Pine, NC 28777

CONDITIONS AND EXCLUSIONS

- A. Replacement of parts may be in the form of new or fully reconditioned parts, at NBC's option.
- B. There is no other express warranty. All implied warranties of Merchantability and Fitness for Use are limited to the duration of the Express Warranty.
- C. New Buck Corporation is not liable for indirect, incidental, or consequential damages in connection with the use of the product including any cost or expense of providing substitute equipment or service during periods of malfunction or non-use.
Some states do not allow the exclusion of incidental or consequential damages, so the above exclusion may not apply to you.
- D. All warranty repairs under this warranty must be performed by an authorized Buck Stove service representative. Repairs or attempted repairs by anyone other than an authorized service representative are not covered under this warranty. In addition, these unauthorized repairs may result in additional malfunctions, the correction of which is not covered by warranty.

OTHER RIGHTS

This warranty gives you specific legal rights, and you may also have other rights, which vary from state to state.

OWNER REGISTRATION CARD

The attached Owner Registration Card must be completed in entirety and mailed within 30 days from the date of purchase or from the date of installation, if installed by a factory certified installer, to New Buck Corporation in order for warranty coverage to begin.

PLEASE NOTE: The Owner Registration Card must contain the Authorized Buck Stove Dealer Code Number and the Certified Installer's number (if applicable) for warranty coverage to begin.

To be completed by selling distributor or dealer for customer:

Warranty Card Not Available On Web & Replacement Versions