

MODEL 21 NON-CATALYTIC UNIT

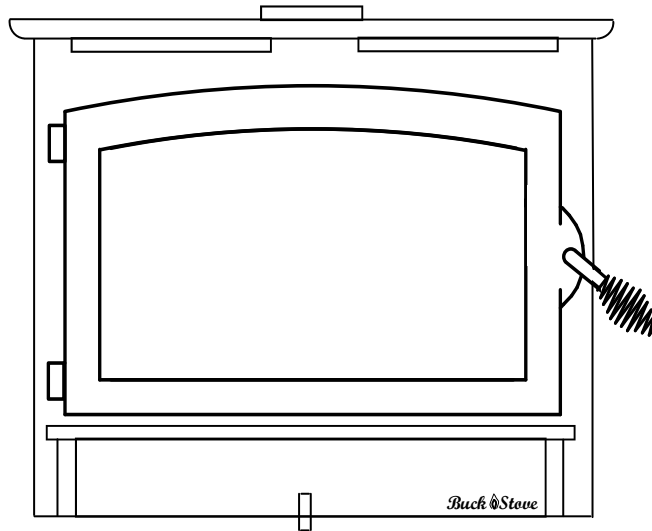

FIREPLACE INSERT & FREESTANDING

FEATURES

PREPARATIONS
OPERATION

INSTALLATION
MAINTENANCE

SAFETY

SAFETY NOTICE

IF THIS HEATER IS NOT PROPERLY INSTALLED, A HOUSE FIRE MAY RESULT. FOR YOUR SAFETY, FOLLOW THE INSTALLATION INSTRUCTIONS. CONTACT THE AUTHORITY HAVING JURISDICTION (SUCH AS MUNICIPAL BUILDING DEPARTMENT, FIRE DEPARTMENT, FIRE PREVENTION BUREAU, etc.) CONSULT BEFORE INSTALLATION TO DETERMINE THE NEED TO OBTAIN A PERMIT. KEEP THESE INSTRUCTIONS FOR FUTURE USE.

TESTED AND LISTED BY:  ITS/WARNOCK HERSEY, MIDDLETON, WI

MANUFACTURED BY NEW BUCK CORPORATION
200 ETHAN ALLEN DRIVE
P.O. BOX 69
SPRUCE PINE, N.C. 28777
www.buckstove.com

Revised July 2010

TABLE OF CONTENTS

Important Instructions	2
SECTION I: Introduction	3
SECTION II: Masonry Insert Installation	4
Floor Protection	5
Masonry Insert Installation options	6
Mounting the Trim Panels	8
SECTION III: Pre-Fab Insert Installation.....	11
SECTION IV: Residential Freestanding Installation.....	12
Out Side Air Installation	12
Floor Protection	14
A. Vertical Exit Using Single Wall Pipe /Listed 2100° UL 103 HT chimney w/out Close Clearance/Pipe Shield.....	15
B. Vertical Wall Exit Using Single Wall Pipe and Elbow /Listed 2100° UL 103 HT Chimney and T-BOX assembly w/out Close Clearance/Pipe Shields	17
Residential and Mobile Home Freestanding Installation (See Page 12) For Out Side Air Installation.	
C. Vertical Exit Using DVL Close Clearance Pipe /Listed 2100° UL 103 HT chimney w/out Close Clearance/Pipe Shields	19
D. Vertical Wall Exit Using DVL Close Clearance Pipe ,and Elbow /Listed 2100° UL 103 HT Chimney and T-BOX assembly w/out Close Clearance/Pipe Shields.....	21
E. Vertical Exit Using DVL Close Clearance Pipe /Listed 2100° UL 103 HT chimney with Close Clearance/Pipe Shields	23
F. Vertical Wall Exit Using DVL Close Clearance Pipe ,and Elbow /Listed 2100° UL 103 HT Chimney and T-BOX assembly with Close Clearance/Pipe Shields.....	25
SECTION V: Alcove Installation	29
Floor Protection	30
Alcove Installation Clearances	31
Installation of Close Clearance Shields	33
SECTION VI: Wood Heater Safety.....	35
SECTION VII: Operation	36
SECTION VIII: Troubleshooting	37
LIMITED WARRANTY	39

INSTALLATION, OPERATION, AND MAINTENANCE INSTRUCTIONS MODEL 21

READ THIS FIRST

IMPORTANT INSTRUCTIONS

WARNING

THIS UNIT GENERATES A LOT OF HEAT, SO TREAT THE UNIT WITH CARE. **HOT WHILE IN OPERATION!** KEEP CHILDREN, CLOTHING AND FURNITURE AWAY. CONTACT MAY CAUSE SKIN BURNS.”DO NOT USE CHEMICALS OR FLUIDS TO START THE FIRE.” “DO NOT BURN GARBAGE OR FLAMMABLE FLUIDS.” DO NOT CONNECT TO ANY DISTRIBUTION DUCT OR SYSTEM. READ ALL INSTRUCTIONS BEFORE INSTALLING AND USING THE APPLIANCE. FAILURE TO FOLLOW INSTRUCTIONS MAY RESULT IN PROPERTY DAMAGE, BODILY INJURY OR EVEN DEATH. SAVE THESE INSTRUCTIONS FOR FUTURE REFERENCES.

- The New Buck Corp. non-catalytic systems have been tested by ITS, Warnock Hersey to ANSI/UL Standards: UL 1482-2000: UL 1482 (2010).
- Install and operate your units according to instructions provided in this manual. Local building codes may apply; therefore, contact your local building inspector or fire marshal for necessary installation requirements and permits which may go beyond these instructions. The authority having jurisdiction should be consulted before installation to determine the need to obtain a permit.
- **If appliance is installed in mobile homes:
“DO NOT INSTALL IN SLEEPING ROOMS.”**
- **NOTE: When burning any unit or appliance that combust fuel for heat, such as coal, oil, wood or natural and (L.P.) liquid petroleum gas. We highly recommend the use of smoke and carbon monoxide detectors in your home.**
- The Model 21 is approved for use in specified Pre-Fabricated fireplaces (ZCF’s). Use the list on Page 11 or contact your dealer for additional units.
- Examine the masonry fireplace and chimney prior to installation of the fireplace accessory to determine that the construction meets the minimum fireplace construction requirements illustrated in the instructions, that it is free from cracks, loose mortar, creosote deposits and other blockage, or other signs of deterioration.

CAUTION

DO NOT USE MORE THAN ONE STOVE TO A CHIMNEY. DO NOT USE A FLUE INTENDED FOR A GAS APPLIANCE.

CAUTION

YOUR CHIMNEY OR FLUE MUST BE CORRECTLY SIZED. A CHIMNEY OR FLUE THAT IS TOO SMALL OR LARGE IN DIAMETER OR TOO SHORT, CAN CAUSE YOUR STOVE TO SPILL SMOKE WHEN THE DOOR IS OPENED.

SECTION I

INTRODUCTION

Your new MODEL 21 is a non-catalytic unit designed to meet the most stringent emissions standards without the use of a catalytic combustor. This effect is achieved through the use of secondary air which is mixed with primary air in the unit's firebox.

For peak performance, we suggest the use of hard seasoned natural wood, loading wood length way from front to rear.

NOTE: Soft woods such as pine, create more creosote, clogging of chimney and produce a less efficient burn performance.

You should not burn trash or garbage, artificial or paper logs, gift wrapping, treated or painted wood or any type of coal.

“DO NOT USE CHEMICALS OR FLUIDS TO START THE FIRE.”

“DO NOT BURN GARBAGE OR FLAMMABLE FLUIDS.”

The primary air, which is controlled by the user, burns the wood. Secondary air is admitted into the firebox through the secondary air tubes at the top of the firebox. This secondary air burns the impurities in the smoke released from the initial wood burning. The temperature necessary for this combustion is maintained through the firebrick refractory. If any more technical information is necessary, contact your local dealer.

A factory-built prefabricated chimney may be used for your unit when installed in compliance with the manufacturer's specification and uniform building code.

These units may also be used with optional room air blower. To order the optional motor assemblies you must specify the stove model number and give one of the following part number:

*Model 21 Motor Assembly—MA 210715

For operation and use of these electrical assemblies, see instructions provided with the motor assembly kits.

SECTION II

MASONRY INSERT INSTALLATION

The Model 21 may be installed using an all masonry fireplace built in accordance with the Uniform Building Code and National Fire Protection Association (NFPA). The first step in this type of installation is to determine the acceptability of the fireplace and chimney for use with a woodstove. Both the construction and condition of the fireplace are important considerations when installing a woodstove. The chimney should extend at least 3' above the roof and at least 2' above any point of the roof within 10'.

CAUTION

REMEMBER TO HAVE YOUR CHIMNEY INSPECTED FOR LEAKS AND BLOCKAGE **BEFORE** YOU INSTALL YOUR STOVE. "DO NOT CONNECT THIS UNIT TO A CHIMNEY FLUE SERVING ANOTHER APPLIANCE."

MINIMUM CLEARANCES TO FLOOR AND COMBUSTIBLES

MINIMUM CLEARANCE MASONRY INSERT

MODEL 21

A. Side Wall Combustible	25"
B. Front Floor Protector	16"
C. Side Floor Protector	8"
D. Side Wood Trim	17"
E. Top Wood Trim	17"
F. Mantel or Brackets	25"

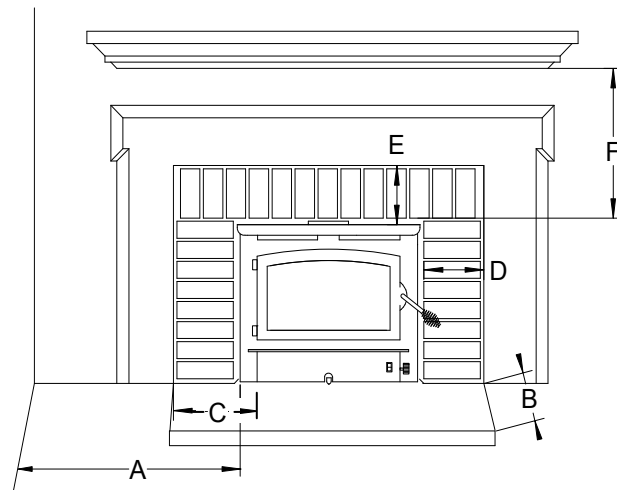

Figure 1

1. The hearth must be of masonry construction and must extend a minimum of 16" in front of the firebox opening and a minimum of 8" to either side of the firebox opening. (See Figure 1).
2. If there is not minimum hearth protection from the front of the firebox opening and the front of the masonry hearth, a floor protector must be used in front of the hearth to protect combustible materials. The floor protector must be 3/8" minimum thickness non-combustible material or equivalent.(See Page 5).

Floor Protection:

When installing freestanding heater, a floor protector must be use. Floor protection must be 3/8” minimum thickness non-combustible material or equivalent.

How to use alternate materials and how to calculate equivalent thickness

An easy means of determining if a proposed alternate floor protector meets requirements listed in the appliance manual is to follow this procedure:

1. Convert specification to R-value:
 - R-value is given—no conversion is needed.
 - K-factor is given with a required thickness (T) in inches:
C-factor is given: $R=1/C$
2. Determine the R-value of the proposed alternate floor protector.
 - Use the formula in step (1) to convert values not expressed as “R”
 - For multiple layers, add R-values of each layer to determine the overall R-value.
3. If the overall R-value of the system is grater than the R-value of the specified floor protector, the alternate is acceptable.

Example:

The specified floor protector should be 3/4” thick material with a K-factor of 0.84.

The proposed alternate is 4” brick with a C-factor of 1.25 over 1/8” mineral board with a K-factor of 0.29.

Step (a): Use formula above to convert specification to R-value. $R= 1/K \times T = 1/0.84 \times .75 = 0.893$

Step (b): Calculate R of proposed system. 4” brick of $C=1.25$, therefore $R_{brick} = 1/C = 1/1.25 = 0.80$ 1/8” mineral board of $K = 0.29$, therefore $R_{min.bd.} = 1/0.29 \times 0.125 = 0.431$

Step (c): Compare proposed system R of 1.231 to specified R of 0.893. Since proposed system R is greater than required , the system is acceptable.

Definitions:

$$\text{Thermal conductance} = C = \frac{\text{Btu}}{(\text{hr})(\text{ft}^2)(\text{°F})} = \frac{\text{W}}{(\text{m}^2)(\text{°K})}$$

$$\text{Thermal conductance} = K = \frac{(\text{Btu})(\text{inch})}{(\text{hr})(\text{ft}^2)(\text{°F})} = \frac{\text{W}}{(\text{m})(\text{°K})} = \frac{(\text{Btu})}{(\text{hr})(\text{ft})(\text{°F})}$$

$$\text{Thermal conductance} = R = \frac{(\text{ft}^2)(\text{hr})(\text{°F})}{\text{Btu}} = \frac{(\text{m}^2)(\text{°K})}{\text{W}}$$

POSSIBLE TOOLS NEEDED FOR INSTALLATION

If you decide to install your own stove, there are several hand tools you may need to do the job. If you do not already have them, they are readily available at most hardware stores.

Caulking gun

Large adjustable wrench (may not be needed)

Drop cloths or newspapers

Vacuum cleaner or whisk broom

Flashlight

1 tube of RTV silicone (Code 103 or 106, or high temperature rubber cement rated between 450° F- 600° F)

7/32" drill bit and drill

Socket/Ratchet Set

INSTALLATION PREPARATION

1. Locate furniture and other materials away from the front of the fireplace to allow free access to the fireplace.
2. Cover the hearth and adjacent floor areas with a drop cloths to protect from soiling or marring the surface.
3. Remove the existing fireplace damper plate.
4. Thoroughly clean the fireplace of ashes and soot.
5. Check the chimney and smoke chamber for excessive buildup of creosote or soot. Also, check for obstructions, such as bird's nests. If the chimney is excessively dirty, clean it, or have someone clean it professionally BEFORE installing or using the room heater.
6. If the fireplace has an ash dump or outside air provision, these must be sealed off with metal or tightly packed non-combustible insulation to prevent cold air from entering the fireplace chamber.

MASONRY INSERT INSTALLATION OPTIONS

This unit (appliance) may be installed into an all masonry fireplace, built in accordance with the Uniform Building Code and the National Fire Protection Association (*NFPA 211*).

NOTE: *Check with local building officials for any permits required for installation of this unit and notify your insurance company before proceeding with installation*

In some cases such as improperly drawing fireplaces , oversize flue liners, or to meet codes in certain areas it is recommended that one of the following procedures be followed:

- A. A **Chimney Connector** be installed from the appliance flue exit through the damper and an air-tight face seal. See option (A) (page 7).
- B. A listed **Direct Connect** be installed from the appliance flue exit through the damper into the first section of the flue liner with air-tight seal. See option (B) (page 7).
- C. A **Positive Connect** be installed from the appliance flue exit continuing up through the entire chimney and exiting at the top of the chimney. See option (C) (page 7).

⚠ SAFETY NOTICE:

If this appliance is not properly installed, a house fire may result. For your safety, follow the installation directions. Contact local building or fire officials about restrictions and installation inspection requirements in your area.

OPTION (A)

SEAL TRIM PANELS AND UNDER FRONT OF STOVE UNIT WITH INSULATION OR HIGH TEMPERATURE CAULK

STARTER PIPE

AIRTIGHT INSULATED CLEAN-OUT

REMOVE DAMPER OR WIRE IT OPEN

NOTE: New Buck Corporation grants no warranty, implied or stated, for the installation or maintenance of your appliance, and assumes no responsibility of any consequential damage

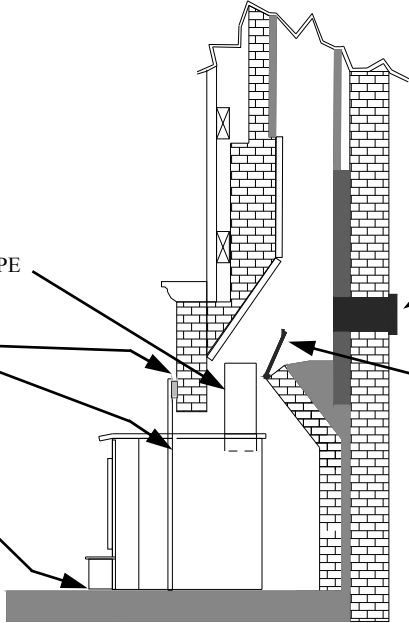

OPTION (B)

NOTE: Follow installation instruction with Direct Connection Kit. (Kit sold separately)

SEAL TRIM PANELS WITH INSULATION OR HIGH TEMPERATURE CAULK

STAINLESS STEEL CHIMNEY CONNECTOR MUST EXTEND 1' PAST THE BLOCK-OFF PLATE OR TO THE FLUE LINER

AIRTIGHT INSULATED CLEAN-OUT

REMOVE DAMPER OR WIRE IT OPEN

BLOCK-OFF PLATE OR DAMPER ADAPTER

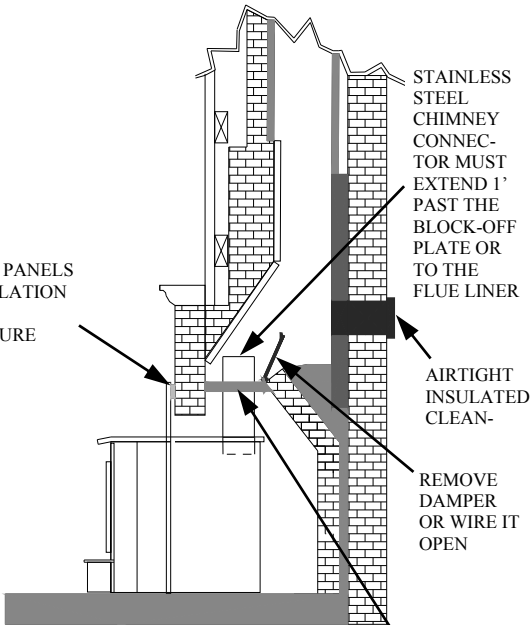

OPTION (C)

NOTE: Follow installation instruction with Positive Connection Kit. (Kit sold separately)

INSTALL A NON-COMBUSTIBLE COVER PLATE TO PREVENT WATER FROM ENTERING THE CHIMNEY

CAP PREVENTS WATER FROM ENTERING)

FLUE LINER

THE LINER MUST BE STAINLESS STEEL CONNECTOR OR FLEXIBLE VENT. FOLLOW THE LINER MANUFACTURER'S INSTRUCTIONS FOR INSTALLATION AND SUPPORT.

AIRTIGHT INSULATED CLEAN-OUT

TRIM PANELS

REMOVE DAMPER OR WIRE IT OPEN

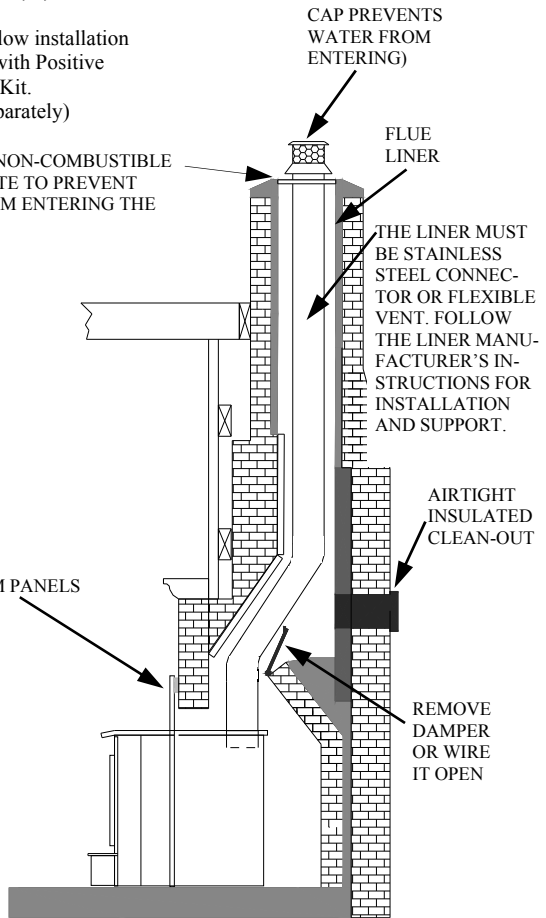

INSTALLATION PROCEDURE (Use a Listed Direct or Positive Connect)

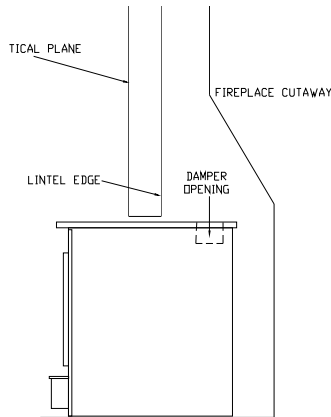

FIGURE 2 POSITIONING

POSITIONING THE HEATER

NOTE: If the three suggested installations have been chosen, certain steps must be followed when installing the heater into a masonry fireplace.

When positioning the heater, the following conditions **MUST** be met! (See Figure 2).

1. The front of the damper opening must be positioned **BEHIND** the rear edge of the lintel to ensure proper draft. (See Figure 2).
2. Center the heater in the fireplace opening.

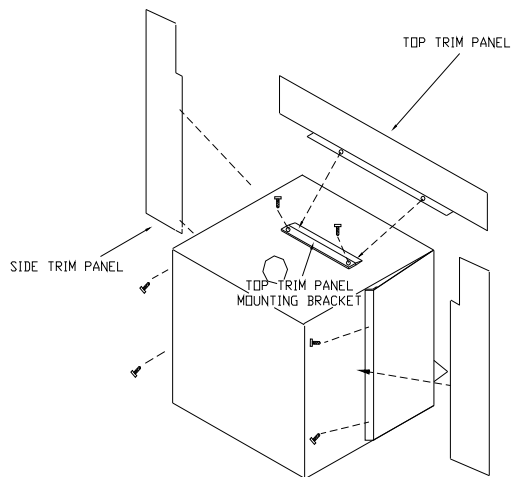

FIGURE 3 MOUNTING TRIM PANELS

MOUNTING THE TRIM PANELS

After the unit is positioned as shown in (Figure 2), mark the mounting position of the trim panels as follows:

1. Place the top long trim panel in place on top of the unit. The panel should be flat against the outside face of the fireplace, and standing vertically. Mark along the lower edge of the trim panel with a pencil to make a reference line for mounting.
2. Place the side trim panels in place behind and against the intake covers, again, flat against the face of the fireplace. Mark down the edge of the trim panel to make a vertical reference line.

3. Slide the unit out of the fireplace far enough to work behind the trim panel reference lines.
4. Mount the side trim panels. (See Figure 3).
 - a. Position the trim panel on the reference line.
 - b. Drill mounting holes in center of trim panels mounting brackets to allow for adjustment in and out if necessary.
 - c. Mount the trim panel using the self-tapping screws provided.
5. Place top panel back on reference mark. Take top trim panel mounting bracket supplied with unit. Position bracket so it overlaps rear lip of top trim panel. Drill mounting holes in top of stove using holes in bracket as guide. Tighten down screws.
6. Now, follow the installation procedures in the listed direct connect or positive connect kit you are using and install the heater and connect kit in the fireplace.
7. Slide the unit back into the fireplace. Check to be sure that the trim panels are properly positioned and lie flat against the front of the fireplace. If one or more of the panels is out of position, slide the unit out and reset by loosening the mounting screws and repositioning in the slot.
8. Reinstall the top trim panel by sliding the rear lip of the top trim panel underneath the front lip of the mounting bracket already secured to top of unit.

NOTE: Mount the top trim panel so that it sits in front of the top of the side trim panels.
9. Obtain the brass trim kit provided with unit and slip over the top and sides of trim panels. (Top ends of brass may need to be trimmed to fit).

10. If direct connect or positive connect kit is not used, follow instructions in (mounting trim panels, steps 1-4c) on (Page 8).
11. Mount top trim panel by drilling mounting holes in center of trim panel mounting brackets, with top end side of top panel overlapping side panel.
12. Using insulation provided, peel and stick to back of panels overlapping fireplace dimensions by 1" on each side and top. (See Page 8, Figure 3).
13. Next using high heat silicone or furnace cement run heavy bead of caulking around where panels meet the stove. (See Figure 4).
14. Slide the unit back into the fireplace. Check to be sure that the trim panels (and brass) are properly positioned and lie flat against the front of the fireplace. If panels are out of position, slide the unit out and reset by loosening the mounting screws and repositioning in the slot. With bar, lift stove in front. Place insulation across front and the surface of hearth or bottom of fireplace, to make complete seal.
15. To check seal of panels, use candle flame and go around the entire area sealed by silicone and insulation. If flame leans toward inside of fireplace, add additional insulation. This ensures an airtight seal.

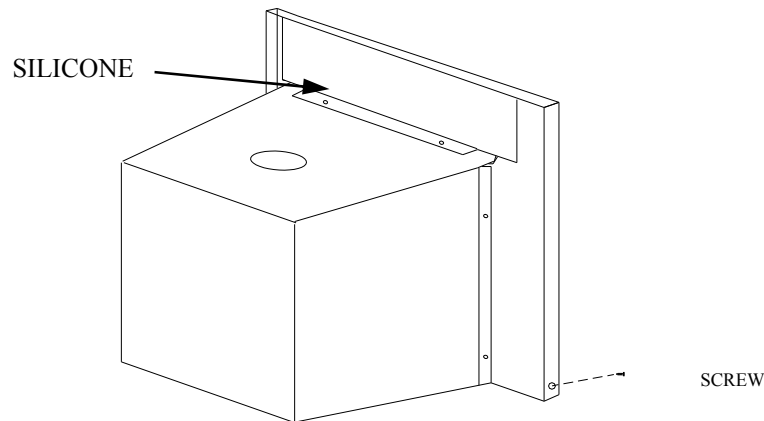

FIGURE 4

FINAL CHECK

1. Recheck the specified clearances.
2. Remove all foreign material from the firebox area.
3. Open the primary air draft.
4. Plug the power cord into a 115V AC outlet if optional motor is being used. Do not run power cord under unit or in high traffic areas.
5. Place crumpled pieces of newspaper in the stove. Light it and close the doors. Ensure that the stove draws properly through the primary draft.
6. Check for smoke leaks around the doors.
7. Open the door and check for smoke escaping from the front of the stove. Smoking usually indicates a defective or poorly positioned chimney. Some chimneys with a marginal draft can be preheated by lighting newspaper and holding it near the open damper with a poker or fire tong. Once the chimney heats up, a proper draft can usually be obtained.

If a thorough review of the Troubleshooting Guide in the rear of the manual does not reveal the problem, contact your dealer for assistance.

CAUTION

THE UNIT IS PAINTED WITH A SPECIALLY FORMULATED HIGH TEMPERATURE PAINT THAT CURES DURING THE FIRST TWO OR THREE FIRINGS. YOU MAY NOTICE A SLIGHT SMOKING EFFECT AND AN ODOR OF BURNING PAINT WHEN YOU BUILD THE FIRST FIRES. THIS IS NORMAL AND IS NOT A CAUSE FOR ALARM. IN SOME CASES, THESE FUMES WILL ACTIVATE A SMOKE ALARM. OPENING A WINDOW NEAR THE UNIT WILL ALLOW THESE FUMES TO ESCAPE. DO NOT BUILD A LARGE, ROARING FIRE UNTIL THIS CURING IS COMPLETE OR THE HEATER FINISH MAY BE DAMAGED.

The connector and/or chimney should be inspected at least once a month during the heating season to determine if a creosote buildup has occurred.

CAUTION

NEVER USE GASOLINE, GASOLINE-TYPE LANTERN FUEL, KEROSENE, CHARCOAL LIGHTER FLUID OR SIMILAR LIQUIDS TO START OR "FRESHEN UP" A FIRE IN THE HEATER. KEEP ALL SUCH LIQUIDS WELL AWAY FROM THE STOVE WHEN IT IS IN USE. ALL FLUIDS OF THIS TYPE GIVE OFF VOLATILE FUMES AND CAN AND WILL EXPLODE!! DON'T TAKE A CHANCE WITH THE SAFETY OF YOUR HOME AND FAMILY.

SECTION III

PRE-FAB INSERT INSTALLATION

The Model 21 has been tested with the following:

Heatilator	Security
Tempco	Preway
Marco	FMI
Woodside	Majestic

NOTE: The Model 21 may be installed in any of the pre-fabricated fireplaces listed above if they are big enough to accept the heater.

NOTE: A FULL CHIMNEY LINER IS REQUIRED IN A ZERO CLEARANCE OR PRE -FABRICATED FIREPLACE.

NOTE: The ash lip, smoke baffle and smoke shelf may be removed if necessary to provide room for these models. **Any other alteration to the unit will void ALL NEW BUCK CORPORATION, responsibility and liability.** The warning label below must be attached to the pre- fabricated fireplace before unit is installed.

Except for the “NOTES” above, please follow the instructions for Masonry Insert Installation including Minimum Clearances for stove and floor protector in Section II.

NOTE: When installing trim panels “DO NOT COVER ANY EXITING LOUVERS OR AIR OPENING IN PRE-FABRICATED FIREPLACE .”

WARNING: This fireplace must be restored to its original condition for safe use, if the fireplace insert is removed.

SECTION IV

RESIDENTIAL FREESTANDING INSTALLATION

TOOLS FOR INSTALLATION

Drop cloth, 3/32" Metal drill bit, 5/16" magnetic socket chuck adapter, 5/16" wrench (box or socket) or adjustable wrench, Jigsaw with masonry, metal and wood blades

WARNING: DO NOT INSTALL IN A SLEEPING ROOM

PREPARING THE STOVE FOR INSTALLATION

1. Remove the protective plastic wrapping from the unit, inspect the unit for any obvious physical damage.
2. Plug the power cord into a 115V AC outlet to test the motor and fan when optional motor is being used. "Do not run power cord under unit or in high traffic areas".
3. Check the primary air draft control to ensure that it slides freely.(See Figure 5).
4. Remove any items from within the firebox. Spread a dropcloth on the floor behind the heater. Next, tilt the heater so that the back is on the drop cloth.
5. **(Leg Kit):** If legs are to be used, obtain four legs, attach the legs to holes in bottom of unit with bolts and washers supplied with the leg kit. (See Figure 5).
6. **(Pedestal Kit):** If pedestal kit is being used (**and outside air is required see below, Outside Air Installation**). Open freestanding kit and obtain the stand. Place the stand against bottom of the heater (angle side to heater). Center stand front to rear and also center stand left and Right. Mark screw locations on bottom of stove through outer holes of stand mounting angles. Set stand aside and drill four 7/32" holes in heater bottom. Before attaching heater to the stand, take a large flat screwdriver or pliers and remove the 2" x 2" knockout on bottom of unit.
(See Figure 5A). Then mount stand to bottom of heater with screws provided. (See Figure 5A).
7. Obtain four (4) 3/16" self-tapping screws and secure the stand to the heater.
8. Reposition the heater to the upright position.

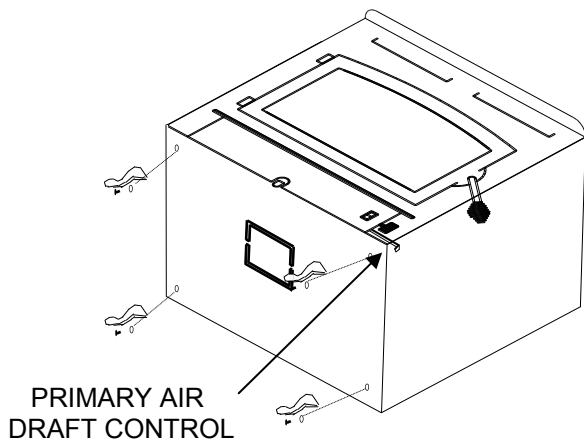

Figure 5

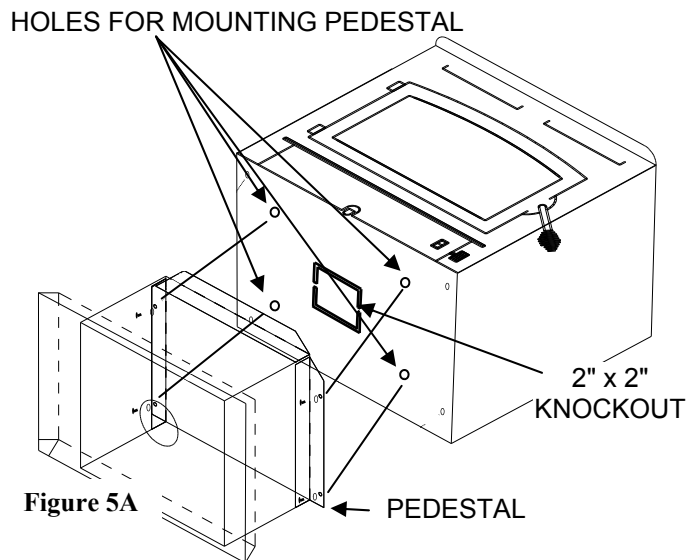

Figure 5A

Out Side Air Installation

CAUTION

THE STRUCTURAL INTEGRITY OF THE MOBILE HOME FLOOR MUST BE MAINTAINED. (MOVE OPENING AND/OR REPOSITION HEATER LOCATION IF NECESSARY).

1. Select an installation location that gives the best airflow from the front of the heater to the remainder of the home.
2. Place the protective floor pad in position. For minim floor protection (See Page 14).

3. Place the unit on the pad making sure the minimum clearance specifications are met.
4. Lightly mark with a pencil the location of the pedestal on the protective pad.
5. Next, remove the four (4) screws holding the heater to the stand. Position heater out of the way of the installation area.
6. Check that the pedestal stand is still aligned with the marks on the protective pad, now mark the outside air opening in bottom of pedestal stand on to the pad.
7. Mark the center line of the outside air opening. Set stand aside for now.
8. Cut a 4 1/4" diameter hole in the pad and continue through the floor.
CAUTION!! The structural integrity of the mobile home floor must be maintained (Move opening and/or reposition heater location if necessary).
9. Now, reposition the pedestal stand and set on the pad being sure to line the stand up with the reference marks.
10. Using an electric drill and 3/8" masonry bit, drill four (4) holes in the protective pad using the holes in the bottom of the pedestal stand as a guide. Be careful to drill only through the pad and not into the floor. Change the bit to a 1/4" metal bit and drill through the floor.
11. Using the four (4) 3/8" x 1-1/2" lag bolts provided, secure the pedestal stand and pad to the floor of the mobile home.

CAUTION

IF A THICK FLOOR PROTECTOR IS USED, YOU MAY HAVE TO USE LONGER LAG BOLTS.

12. Obtain the outside air duct from the box in the pedestal kit marked FA P21B.
13. Slip the duct down through the 4-1/4" hole until the face of the outside air duct with screen wire, contacts the bottom of pedestal.
14. Secure the outside air duct to the inside bottom of pedestal using the four (4) #10x1 screws provided. (See Figure 6).
15. Set the heater back onto the stand and resecure using the screws.
16. NOTE: If home is underpinned, you must duct through underpin as shown. (See Figure 6A).

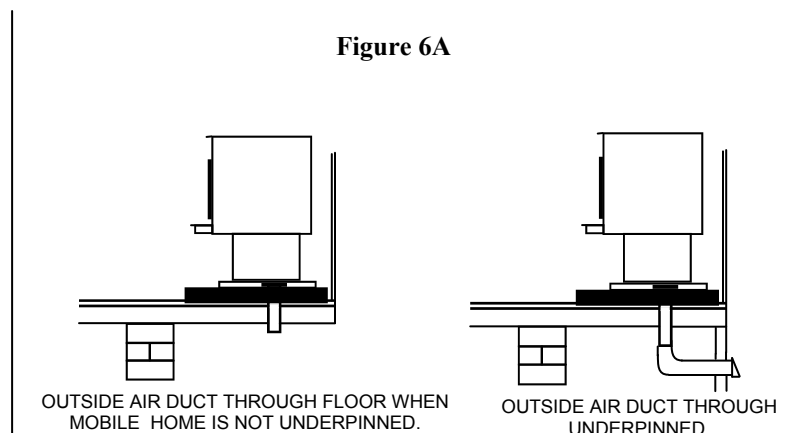
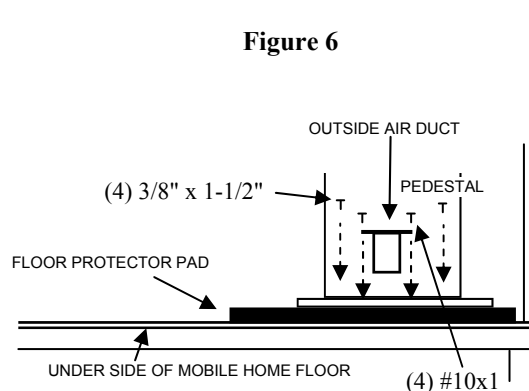

Floor Protection:

Floor protection must be 3/8" minimum thickness non-combustible material or equivalent.

How to use alternate materials and how to calculate equivalent thickness

An easy means of determining if a proposed alternate floor protector meets requirements listed in the appliance manual is to follow this procedure:

1. Convert specification to R-value:
 - R-value is given—no conversion is needed.
 - K-factor is given with a required thickness (T) in inches:
 - C-factor is given: $R=1/C$
2. Determine the R-value of the proposed alternate floor protector.
 - Use the formula in step (1) to convert values not expressed as "R"
 - For multiple layers, add R-values of each layer to determine the overall R-value.
3. If the overall R-value of the system is greater than the R-value of the specified floor protector, the alternate is acceptable.

Example:

The specified floor protector should be 3/4" thick material with a K-factor of 0.84.

The proposed alternate is 4" brick with a C-factor of 1.25 over 1/8" mineral board with a K-factor of 0.29.

Step (a): Use formula above to convert specification to R-value. $R= 1/K \times T = 1/0.84 \times .75 = 0.893$

Step (b): Calculate R of proposed system. 4" brick of $C=1.25$, therefore $R_{brick} = 1/C = 1/1.25 = 0.80$ 1/8" mineral board of $K = 0.29$, therefore $R_{min.bd.} = 1/0.29 \times 0.125 = 0.431$

Step (c): Compare proposed system R of 1.231 to specified R of 0.893. Since proposed system R is greater than required, the system is acceptable.

Definitions:

$$\text{Thermal conductance} = C = \frac{\text{Btu}}{(\text{hr})(\text{ft}^2)(\text{°F})} = \frac{\text{W}}{(\text{m}^2)(\text{°K})}$$

$$\text{Thermal conductance} = K = \frac{(\text{Btu})(\text{inch})}{(\text{hr})(\text{ft}^2)(\text{°F})} = \frac{\text{W}}{(\text{m})(\text{°K})} = \frac{(\text{Btu})}{(\text{hr})(\text{ft})(\text{°F})}$$

$$\text{Thermal conductance} = R = \frac{(\text{ft}^2)(\text{hr})(\text{°F})}{\text{Btu}} = \frac{(\text{m}^2)(\text{°K})}{\text{W}}$$

Install in accordance with 24 CFR, Part 3280 (HUD).

Chimney

This model is designed for connection to any listed 2100° UL103 HT chimneys and parts. Follow chimney manufacturer's instructions carefully.

This room heater must be converted to (1) a chimney complying with the requirements for Type HT chimneys in the Standard for chimneys, Factory-Built, Residential, Type and Building Heating Appliance, UL 103 or (2) a code approved masonry chimney with a flue liner.

PREPARING THE ROOM HEATER LOCATION

1. Select an installation location that will give the best airflow from the front of the heater to the remainder of the home.
2. Place the protective floor pad in position.
3. Place the unit on the pad making sure the minimum clearance specifications are met.
4. If connecting to an existing masonry flue, first ensure that the flue conforms to the **NFPA-211** Code and/or consult your local code for proper procedures.

NOTE: This model is designed for connection to: any Listed 2100° UL 103 HT. TYP chimney also any Listed UL DVL Close Clearance Pipe or Single wall minimum 24 ga. Blued or Black Pipe. Follow pipe manufacturer's instructions carefully.

CHIMNEY

This room heater must be converted to (1) a chimney complying with the requirements for Type HT chimneys in the Standard for Chimneys, Factory-Built, Residential, Type and Building Heating Appliance, UL 103, or (2) a code approved masonry chimney with flue liner.



CAUTION: Certain installation types require the use of certain chimney types. Please follow these instructions exactly.

HOW TO LOCATE CHIMNEY EXIT AND INSTALL

Residential Installation

A. Vertical Exit using (6" Single Wall minimum 24 ga. blued or black pipe and any Listed 2100° UL 103 HT. chimney).

Without optional close clearance shield, and pipe shield.

NOTE: For minimum clearances (See Page 16, Figure 7).

1. Suspend a plumb bob from the ceiling above the unit so that the weight is hanging in the center of the flue exit. (A small weight on a string will serve as a plumb bob). Mark the ceiling where the string is suspended to locate the center of the chimney.
2. After locating the center of the hole, install the ceiling support box, chimney or chimney connector, flashing, and rain cap per the chimney manufacturer's instructions, and local building codes for installation through combustible walls or ceilings.
3. Now connect the stove and ceiling support box using 6" Single Wall minimum 24 ga. blued or black pipe (DO NOT USE GALVANIZED PIPE). Connect each section so the crimped end faces downward, and secure each section to each other using at least three (3) sheet metal screws or rivets. Single wall pipe is to be connected with (3) sheet metal screws or rivets to connector collar on heater.(See Page 16, Figure 8).

**A. Vertical exit using (6" Single Wall minimum 24 ga. blued or black pipe and any listed 2100° UL 103 HT. TYPE Chimney).
Without optional close clearance shield and pipe shield.
Model 21 minimum clearance to combustibles.**

Figure 7

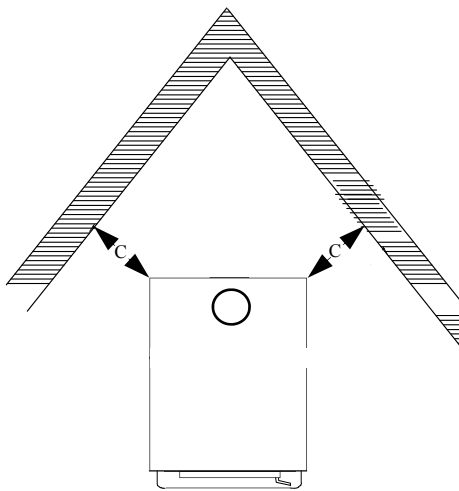
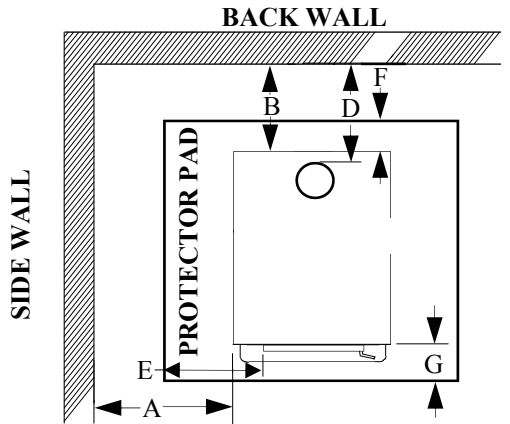

A B C D E F G

MODEL 21 25" 13" 13" 15.5" 8" 6" 16"

Figure 8

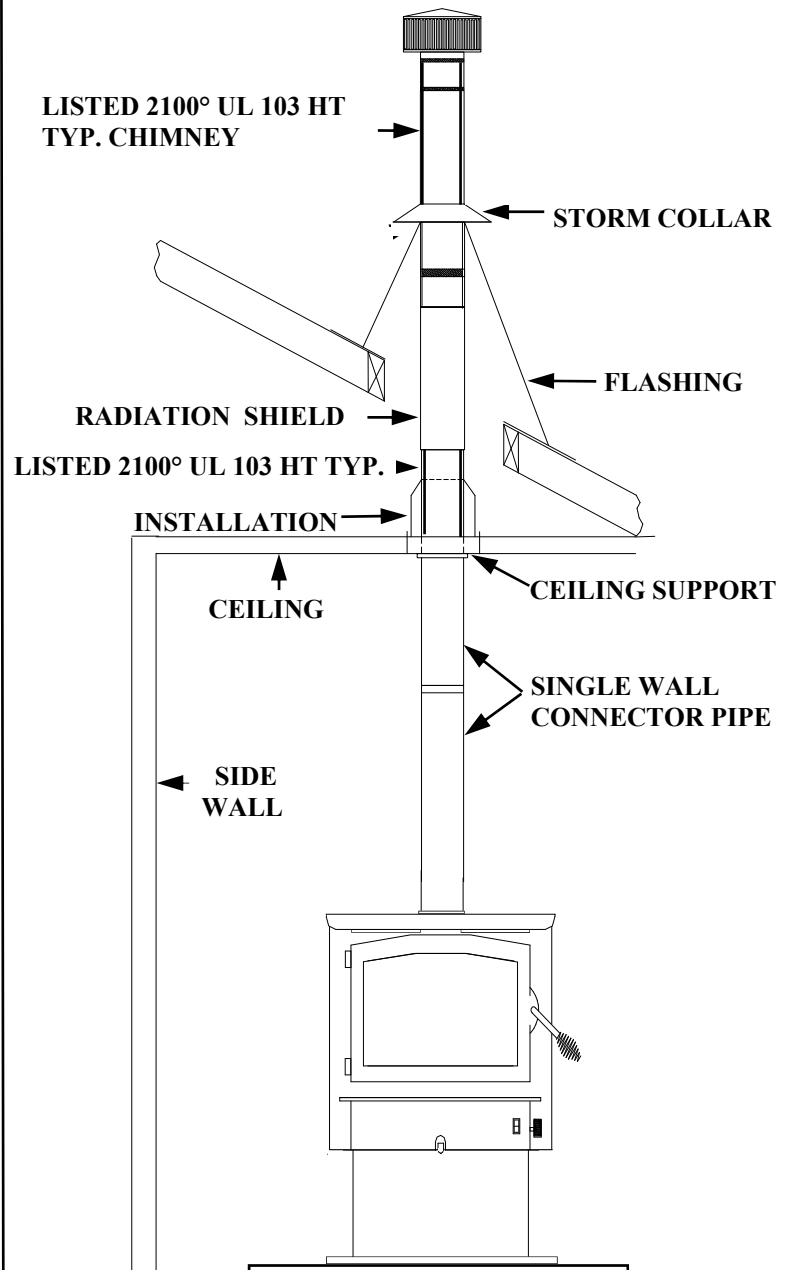

NOTE: All clearances are to combustibles without close clearance shields, and pipe shield, using 6" Single Wall minimum 24 ga. blued or black pipe, and minimum floor protector. The clearances above may be reduced. Follow NFPA-211 codes if available or follow instructions on (Pages 19, 20 or Pages 23, 24).

HOW TO LOCATE CHIMNEY EXIT AND INSTALL

Residential Installation

- B. Vertical Wall Exit using (6" Single Wall minimum 24 ga. blued or black pipe with elbow and any Listed 2100° UL HT chimney and Listed 2100° UL HT. T-Box assembly). Without optional close clearance shields and pipe shield**

NOTE: For minimum clearances (See Page 18, Figure 9).

1. Mark the plumb line on the wall directly behind the center of the heater.
(See Page 18, Figure 10).
NOTE: When using 6" Single Wall minimum 24ga. blued or black pipe, "maintain 18" minimum clearances" between pipe and ceiling".
2. Place the vertical portion of the heater pipe and the elbow in position and project a point onto the plumb line level with the center of the elbow.
3. Measure up so there will be at least 1/4" rise per foot of horizontal connector pipe, maintaining clearances to the ceiling as noted in (Page 18, Figure 10). This will give you the center of the hole for the chimney penetration.
4. After locating the center of the penetration, install the tee-box and chimney as per the chimney manufacturer's specifications.
5. Connect the chimney collar to the tee-box using 6" Single Wall minimum 24 ga. blued or black pipe. (DO NOT USE GALVANIZED PIPE). Connect each section so the crimped end faces downward, and secure each section to each other using three (3) sheet metal screws or rivets. Single wall pipe is to be connected with three (3) sheet metal screws rivets to connector collar on heater. (See Page 18, Figure 10).

B. Vertical wall exit using (6" Single Wall minimum 24 ga. blued or black pipe with elbow and any listed 2100° UL 103 HT. TYPE Chimney and Listed 2100° UL HT. T-Box assembly). Without optional close clearance shield and pipe shield. Model 21 minimum clearance to combustibles.

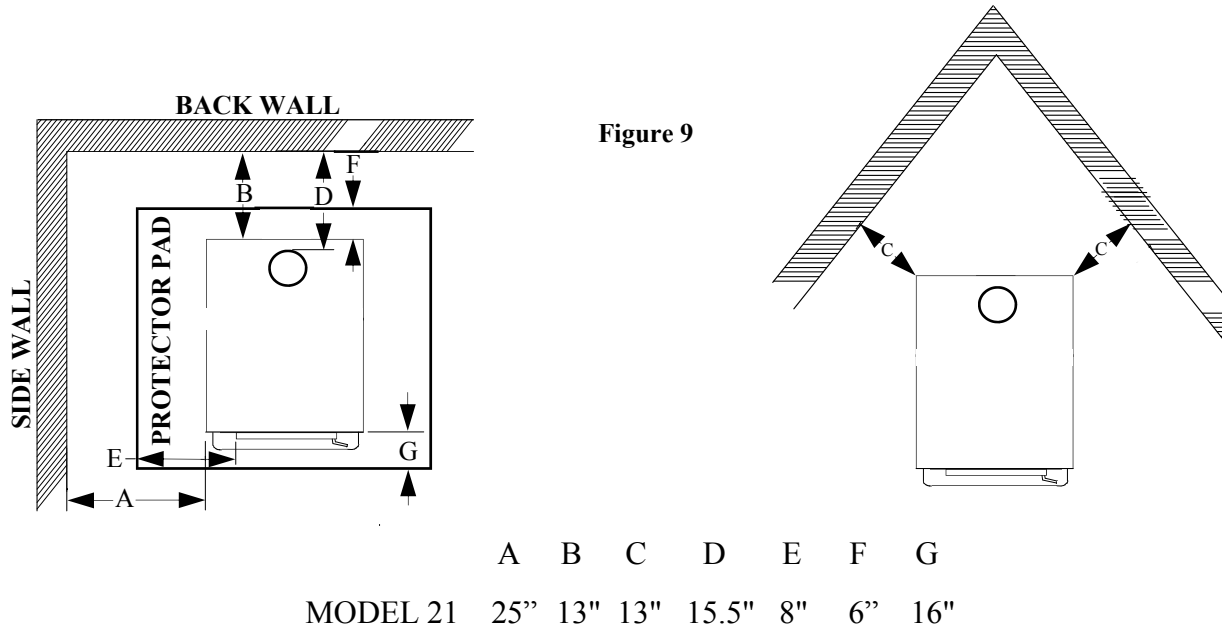

NOTE: All clearances are to combustibles without close clearance shields and pipe shield, 6" Single Wall minimum 24 ga. blued or black pipe with elbow, and minimum floor protector. Clearances above may be reduced. Follow **NFPA-211** codes if available or follow instructions on (Pages 21,22 or Pages 25, 26).

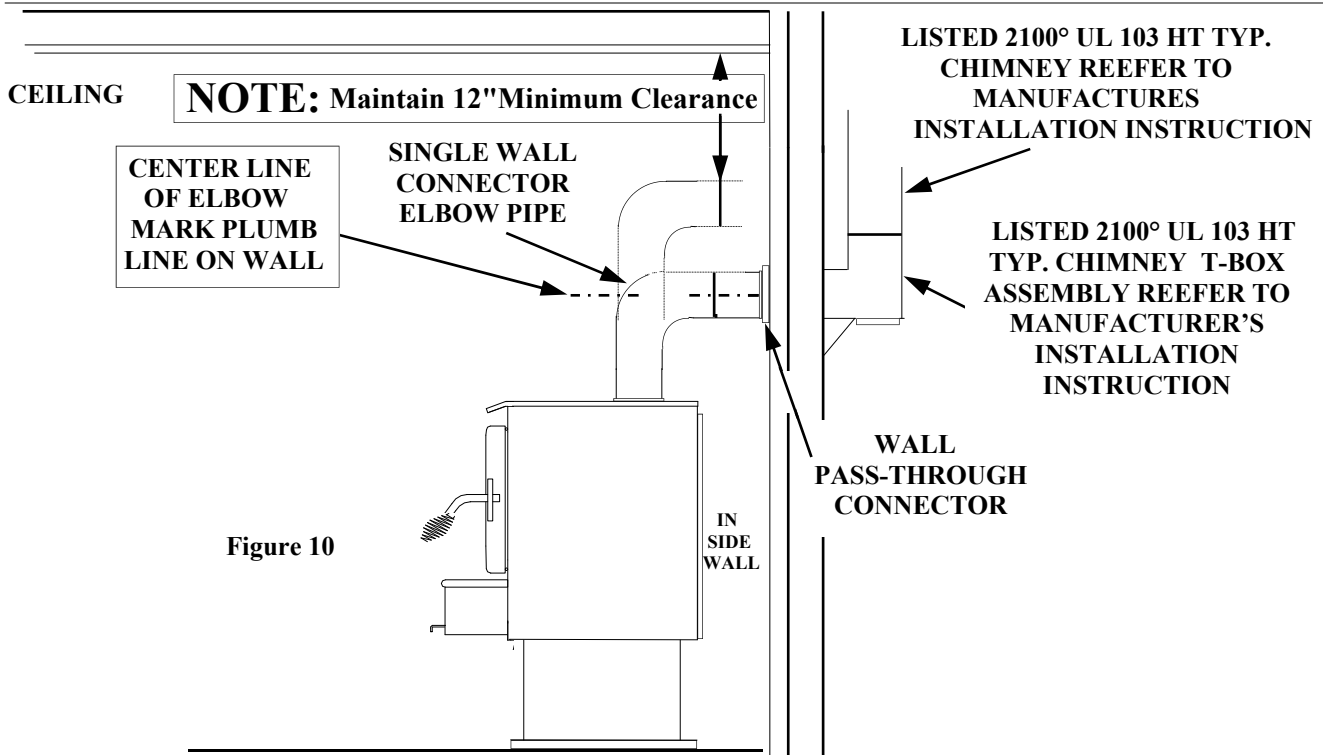

HOW TO LOCATE CHIMNEY EXIT AND INSTALL

Residential and Mobile Home Installation

C. Vertical Exit using (6" DVL Close Clearance pipe and any Listed 2100° UL 103 HT chimney).

Without close clearance shield and pipe shield.

NOTE: For minimum clearances (See Page 20, Figure 11).

1. Suspend a plumb bob from the ceiling above the unit so that the weight is hanging in the center of the flue exit. (A small weight on a string will serve as a plumb bob). Mark the ceiling where the string is suspended to locate the center of the chimney.
2. After locating the center of the hole, install the ceiling support box, chimney or chimney connector, flashing, and rain cap per the chimney manufacturer's instructions, and local building codes for installation through combustible walls or ceilings.
3. Now connect the stove and ceiling support box using DVL close clearance pipe. Connect each section per manufacturer's instructions. Secure each section to each other using minimum (3) sheet metal screws or rivets. DVL close clearance is to be connected with (3) sheet metal screws or rivets to connector collar on heater (See Page 20, Figure 12).

C. Vertical exit using (6" DVL Close Clearance pipe and any listed 2100° UL 103 HT. TYPE Chimney). Without optional close clearance shield and pipe shield. Model 21 minimum clearance to combustibles.

Figure 11

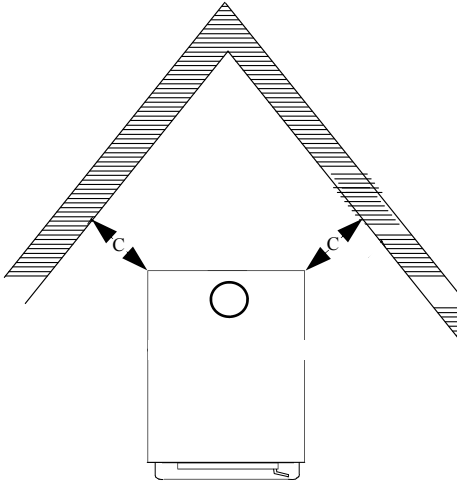
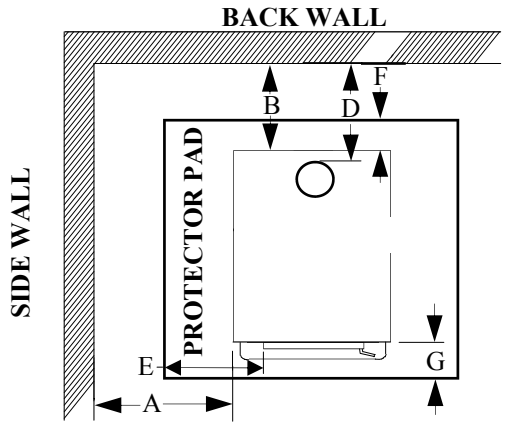

A B C D E F G

MODEL 21 23" 9" 9" 10.5" 8" 6" 16"

Figure 12

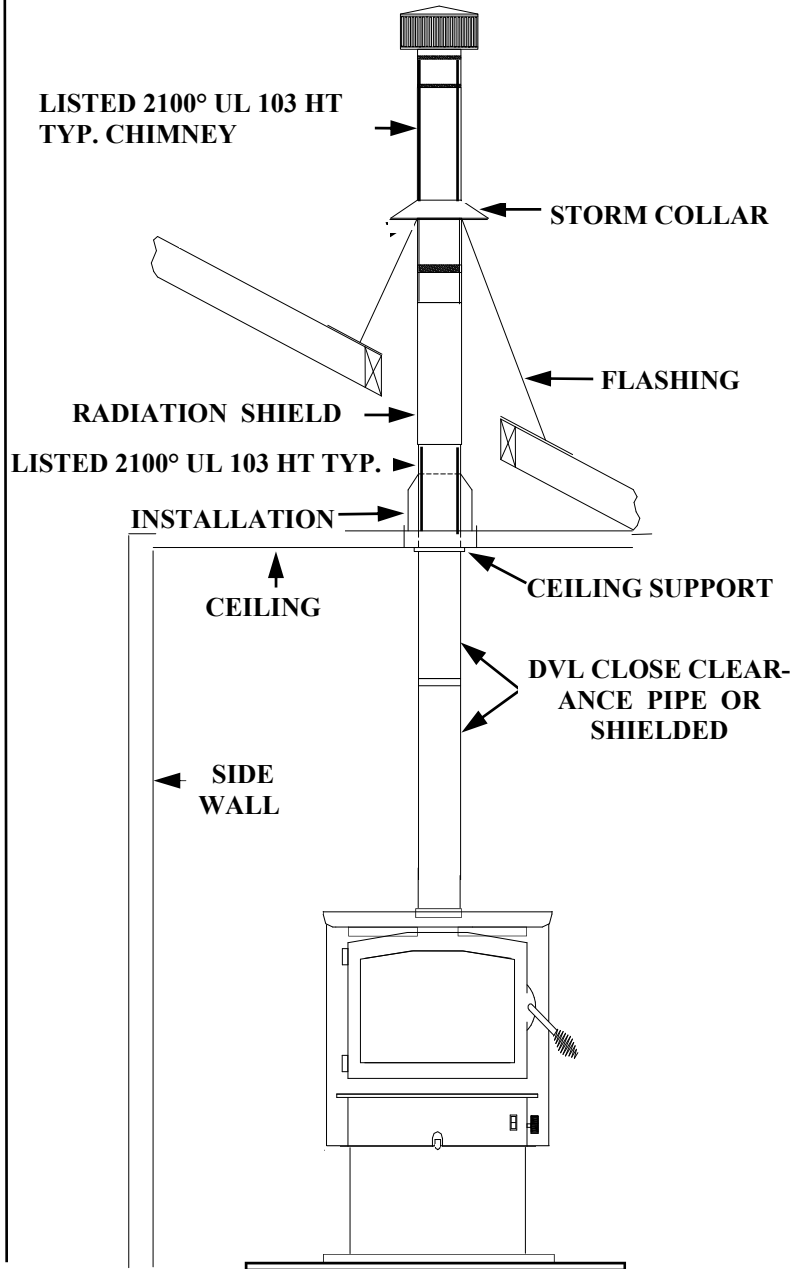

NOTE: All clearances are to combustibles without close clearance shields, and pipe shield, using DVL Close Clearance pipe , and minimum floor protector. protector . The clearances above may be reduced. Follow NFPA-211 codes if available or follow instructions on (Pages 23 and 24).

HOW TO LOCATE CHIMNEY EXIT AND INSTALL

Residential and Mobile Home Installation

D. Vertical Wall Exit using (6" DVL Close Clearance Pipe and Elbow and any Listed 2100° UL HT chimney and Listed 2100° UL HT T-Box assembly).

Without optional close clearance shield and pipe shield.

NOTE: For minimum clearances (See Page 22, Figure 13).

1. Mark the plumb line on the wall directly behind the center of the heater.
(See Page 22, Figure 14).

NOTE: When using DVL Close Clearance Pipe , “maintain manufacturer’s minimum clearances” between pipe and ceiling.

2. Place the vertical portion of the heater pipe and the elbow in position and project a point onto the plumb line level with the center of the elbow.
3. Measure up so there will be at least 1/4" rise per foot of horizontal connector pipe, maintaining clearances to the ceiling as noted in (Page 21, Figure 14). This will give you the center of the hole for the chimney penetration.
4. After locating the center of the penetration, install the tee-box and chimney as per the chimney manufacturer's specifications.
5. Connect the DVL close clearance pipe to the tee-box per manufacturer’s instructions, DVL close clearance pipe is to be connected with (3) sheet metal screws or rivets to connector collar on heater (See Page 22, Figure 14).

D. Vertical wall exit using (6" DVL Close Clearance pipe with elbow) and any listed 2100° UL 103 HT. TYPE Chimney and Listed 2100° UL HT T-Box assembly). Without optional close clearance shield and pipe shield. Model 21 minimum clearance to combustibles.

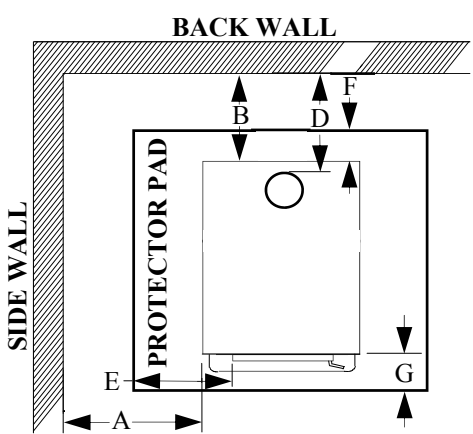
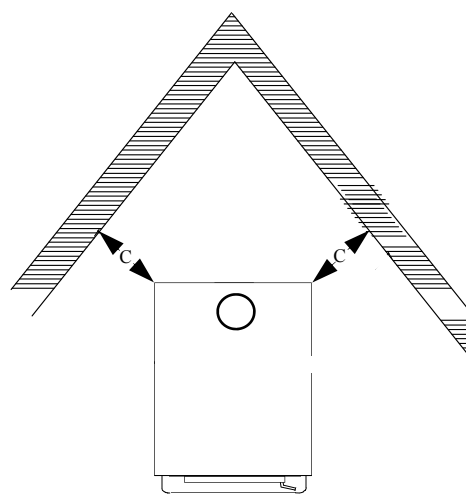

Figure 13



	A	B	C	D	E	F	G
MODEL 21	23"	9"	9"	10.5"	8"	6"	16"

NOTE: All clearances are to combustibles without close clearance shields and pipe shield, DVL Close Clearance pipe with elbow, and minimum floor protector. The clearances above may be reduced. Follow NFPA-211 codes if available or follow instructions on (Pages 25 and 26).

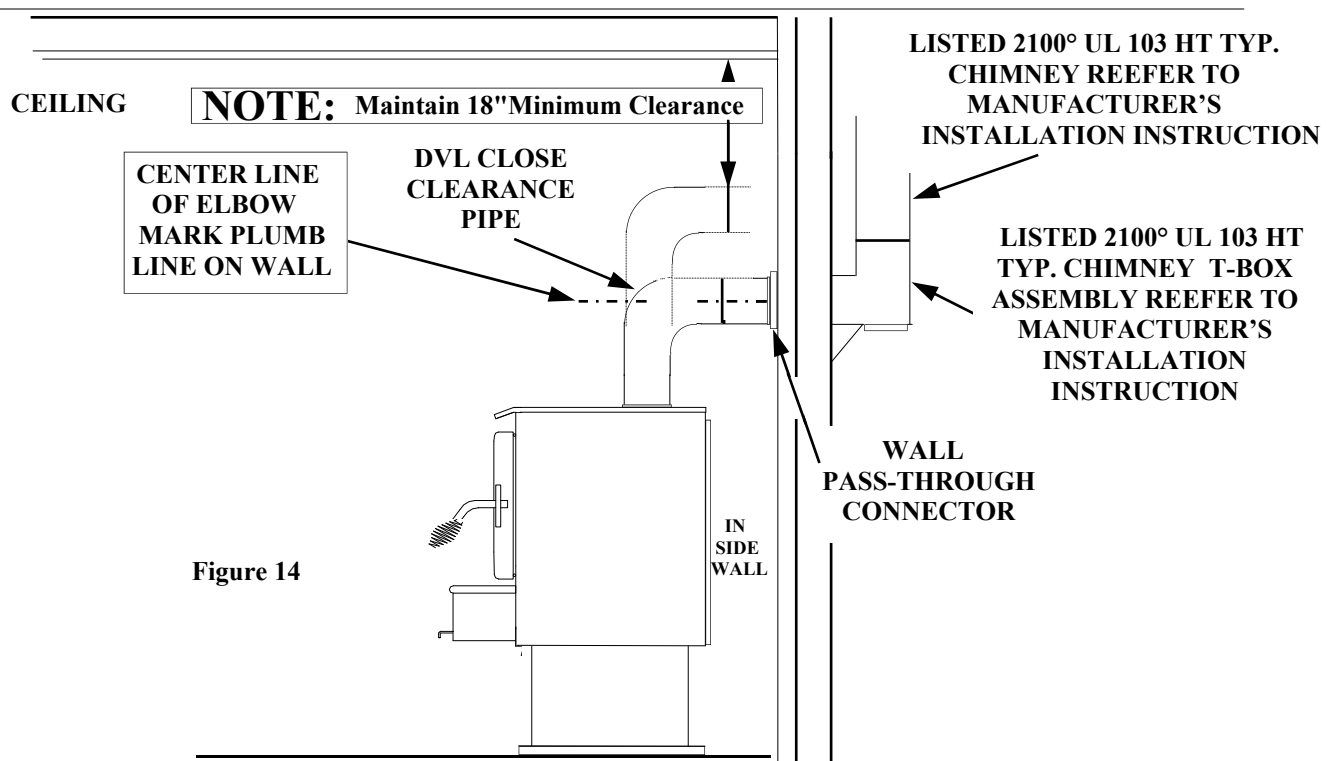

Figure 14

HOW TO LOCATE CHIMNEY EXIT AND INSTALL

Residential and Mobile Home Installation

E. Vertical Exit using (6" DVL Close Clearance pipe and any Listed 2100° UL 103 HT chimney).

With optional close clearance shield and pipe shield. NOTE: For installation of optional close clearance shields and pipe shield (See Page 33).

NOTE: For minimum clearances (See Page 24, Figure 15).

If pedestal kit is being used and out side air is required (See Page 13).

1. Suspend a plumb bob from the ceiling above the unit so that the weight is hanging in the center of the flue exit. (A small weight on a string will serve as a plumb bob). Mark the ceiling where the string is suspended to locate the center of the chimney.
2. After locating the center of the hole, install the ceiling support box, chimney or chimney connector, flashing, and rain cap per the chimney manufacturer's instructions, and local building codes for installation through combustible walls or ceilings.
3. Now connect the stove and ceiling support box using DVL close clearance pipe. Connect each section per manufacturer's instructions. Secure each section to each other using minimum (3) sheet metal screws or rivets. DVL close clearance is to be connected with (3) sheet metal screws or rivets to connector collar on heater (See Page 24, Figure 16).

**E. Vertical exit using (6" DVL Close Clearance pipe and any listed 2100° UL 103 HT. TYPE Chimney).
With optional close clearance shield and pipe shield.
Model 21 minimum clearance to combustibles.**

Figure 15

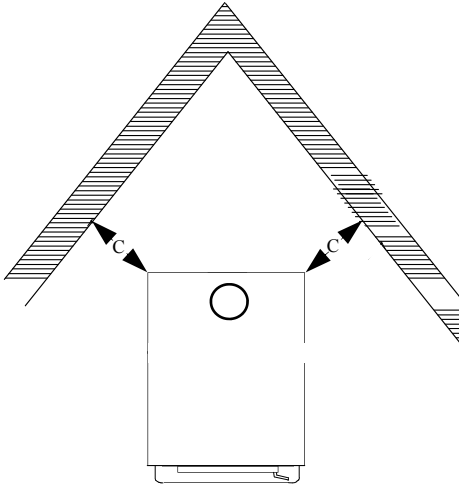
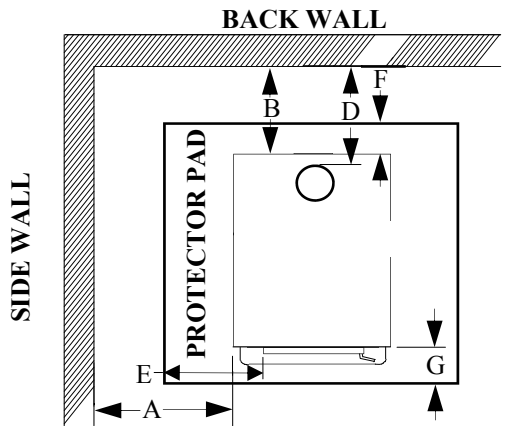

A B C D E F G

MODEL 21 19" 7" 7" 8.5" 8" 6" 16"

Figure 16

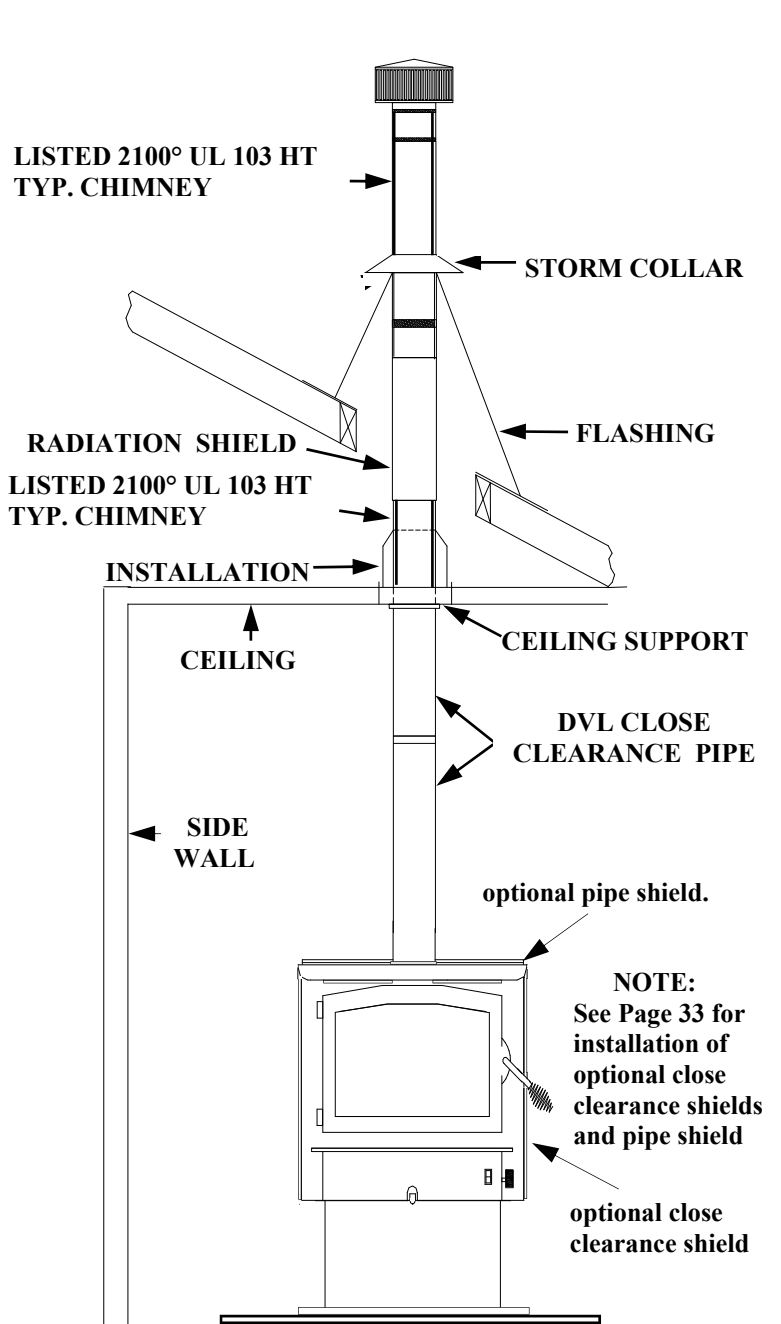

NOTE:
See Page 33 for
installation of
optional close
clearance shields
and pipe shield

optional pipe shield.
optional close
clearance shield

NOTE: All clearances are to combustibles with optional close clearance shields, and pipe shield, using DVL Close Clearance pipe, and minimum floor protector.

HOW TO LOCATE CHIMNEY EXIT AND INSTALL

Residential and Mobile Home Installation

F. Vertical Wall Exit using (6" DVL Close Clearance Pipe and Elbow and any Listed 2100° UL HT chimney and Listed 2100° UL HT T-Box assembly).

With optional close clearance shield and pipe shield **NOTE: For installation of optional close clearance shields and pipe shield (See Page 33).**

NOTE: For minimum clearances (See Page 26, Figure 17).

If pedestal kit is being used and out side air is required (See Page 13).

1. Mark the plumb line on the wall directly behind the center of the heater.
(See Page 26, Figure 18).
NOTE: When using DVL Close Clearance Pipe , “maintain manufacturer’s minimum clearances” between pipe and ceiling.
2. Place the vertical portion of the heater pipe and the elbow in position and project a point onto the plumb line level with the center of the elbow.
3. Measure up so there will be at least 1/4" rise per foot of horizontal connector pipe, maintaining clearances to the ceiling as noted in (Page 26, Figure 18). This will give you the center of the hole for the chimney penetration.
4. After locating the center of the penetration, install the tee-box and chimney as per the chimney manufacturer's specifications.
5. Connect the DVL close clearance pipe to the tee-box per manufacturer’s instructions. DVL close clearance pipe is to be connected with (3) sheet metal screws or rivets to connector collar on heater.(See Page 26, Figure 18).

**F. Vertical wall exit using (6" DVL Close Clearance pipe with elbow and any listed 2100° UL 103 HT. TYPE Chimney and Listed 2100° UL HT T-Box assembly).
With optional close clearance shield and pipe shield.
Model 21 minimum clearance to combustibles.**

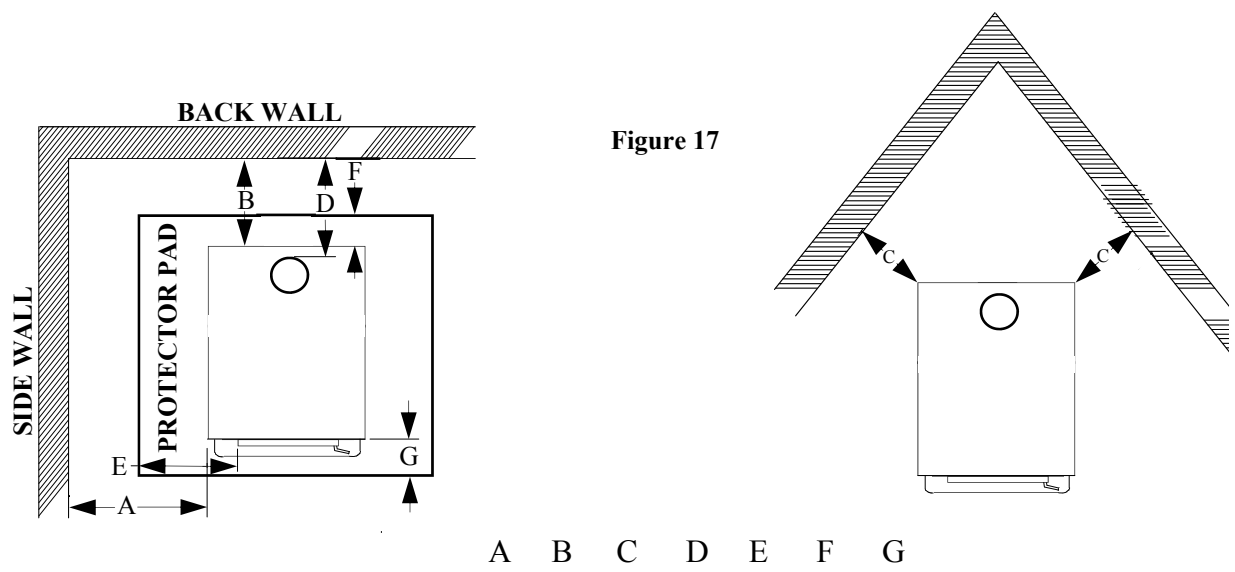

Figure 17

	A	B	C	D	E	F	G
MODEL 21	19"	7"	7"	8.5"	8"	6"	16"

NOTE: All clearances are to combustibles with close clearance shields and pipe shield, DVL Close Clearance pipe with elbow, and minimum floor protector.

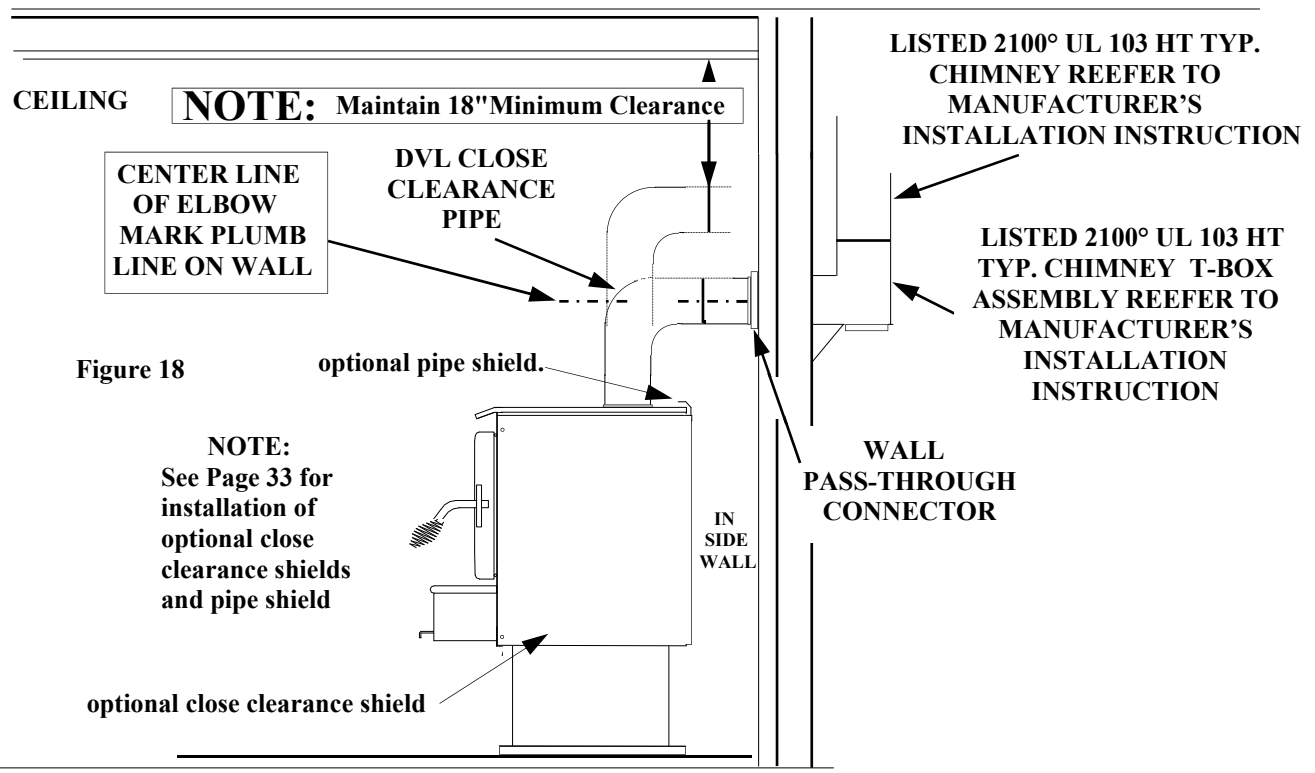

Figure 18

NOTE: Maintain 18" Minimum Clearance

CENTER LINE OF ELBOW MARK PLUMB LINE ON WALL

DVL CLOSE CLEARANCE PIPE

optional pipe shield.

NOTE: See Page 33 for installation of optional close clearance shields and pipe shield

optional close clearance shield

IN SIDE WALL

WALL PASS-THROUGH CONNECTOR

LISTED 2100° UL 103 HT TYP. CHIMNEY REEFER TO MANUFACTURER'S INSTALLATION INSTRUCTION

LISTED 2100° UL 103 HT TYP. CHIMNEY T-BOX ASSEMBLY REEFER TO MANUFACTURER'S INSTALLATION INSTRUCTION

Ceiling Exit (Using Close Clearance listed chimney)

1. Suspend a plumb bob from the ceiling above the unit so that the weight is hanging in the center of the flue exit. (A small weight on a string will serve as a plumb bob). Mark the ceiling where the string is suspended to locate the center of the chimney hole.
2. After locating the center of the hole install the ceiling support box, chimney flashing and rain cap. Only use 2100° UL 103 HT chimney and parts listed in this manual per the chimney manufacturer's instruction.

CAUTION

REFER TO CHIMNEY MANUFACTURER'S INSTRUCTIONS FOR ASSEMBLY AND DISASSEMBLY OF CHIMNEY PARTS. BE SURE TO FOLLOW CHIMNEY INSTRUCTIONS FOR PROPER CLEARANCES TO COMBUSTIBLE AND PROPER AIR SPACING REQUIRED.

3. Add additional pipe until both of the following are met:
 - (a) Chimney pipe is 3 feet higher than roof at the point where it penetrates the roof.
 - (b) Chimney pipe height is at least 2 feet higher than any part of the roof within 10 feet of the chimney.
 (See Figure 19A).

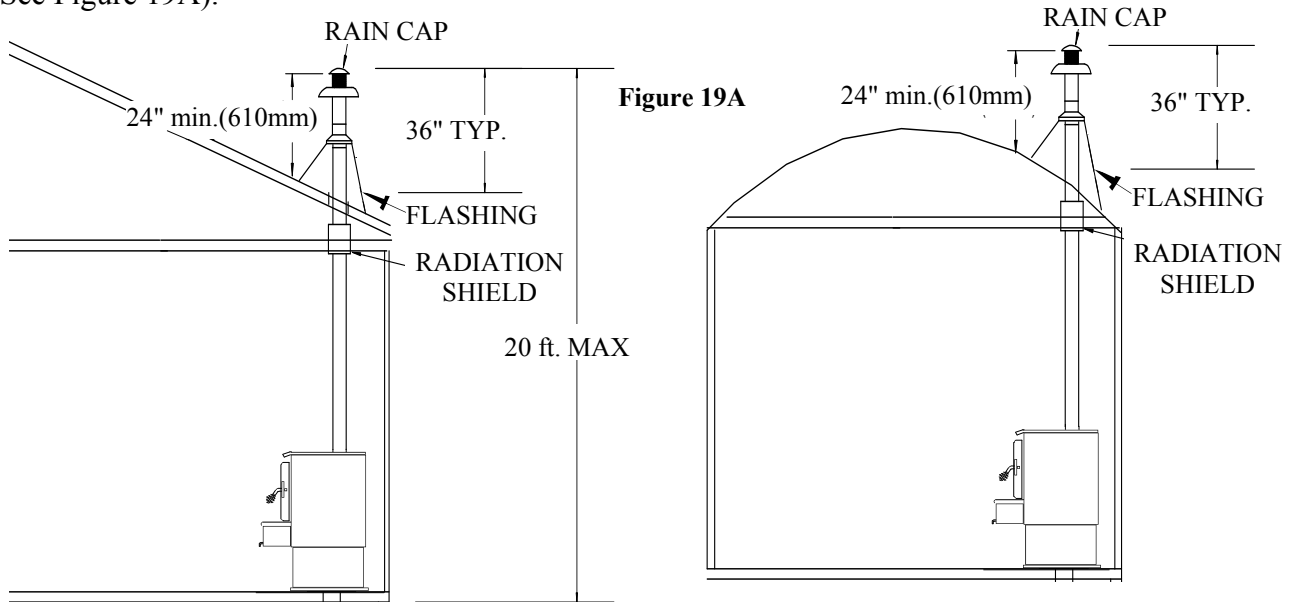

4. Using only double wall chimney connector listed in this manual (See Page 11), connect the heater to the chimney by following chimney manufacturer's installation instructions exactly. (See Figure 19B).

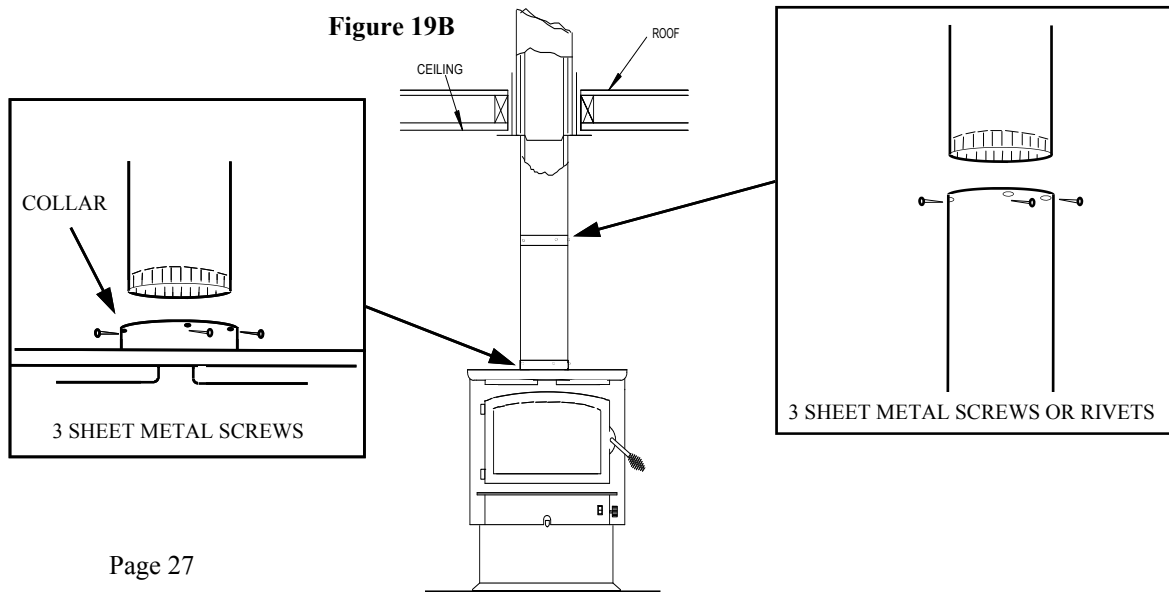

FINAL CHECK

1. Recheck the specified clearances.
2. Remove all foreign material from the firebox area.
3. Open the primary air draft.
4. Plug the power cord into a 115V AC outlet when using with optional motor. “Do not run power cord under unit or in high traffic areas”.
5. Place crumpled pieces of newspaper in the stove. Light it and close the doors. Ensure that the stove draws properly through the primary draft.
6. Check for smoke leaks around the door.

CAUTION

Open the doors and check for smoke escaping from the front of the stove. Smoking usually indicates a defective or poorly positioned chimney. Some chimneys with a marginal draft can be preheated by lighting newspaper and holding it near the open damper with a poker or fire tong. Once the chimney heats up, a proper draft can usually be obtained.

If a thorough review of the Troubleshooting Guide in the rear of the manual does not reveal the problem, contact your dealer for assistance.

CAUTION

The unit is painted with a specially formulated high temperature paint that cures during the first two or three firings. You may notice a slight smoking effect and an odor of burning paint when you build the first fires. This is normal and is not a cause for alarm. In some cases, these fumes will activate a smoke alarm. Opening a window near the unit will allow these fumes to escape. DO NOT build a large, roaring fire until this curing is complete or the heater finish may be damaged.

SECTION V

ALCOVE INSTALLATION AND CLEARANCES

Select an installation location that will give the best airflow from the front of the heater to the remainder of the home

PREPARING THE STOVE FOR INSTALLATION

1. Inspect the unit for any obvious physical damage.
2. Plug the power cord into a 115V AC outlet to test the motor and fan when optional motor is being used. "Do not run power cord under unit or in high traffic areas".
3. Check the primary air draft control to ensure that it slides freely.(See Figure 20).
4. Remove any items from within the firebox. Spread a dropcloth on the floor behind the heater. Next, tilt the heater so that the back is on the drop cloth.
5. If leg kit is to be used follow steps 1-6.
6. Then obtain four legs, attach the legs to holes in bottom of unit with bolts and washers supplied with the leg kit. (See Figure 20).
7. Open freestanding kit and obtain the stand. Place the stand against bottom of heater (angle side to heater).Center stand front to rear and also center stand left and right. Mark screw locations on bottom of the stove through outer holes of stand mounting angles. Set stand aside and drill four 7/32" holes in heater bottom.Then mount stand to bottom of heater with screws provided. (See Figure 21).
8. Obtain four (4) 3/16" self-tapping screws and secure the stand to the heater.
9. Reposition the heater to the upright position.

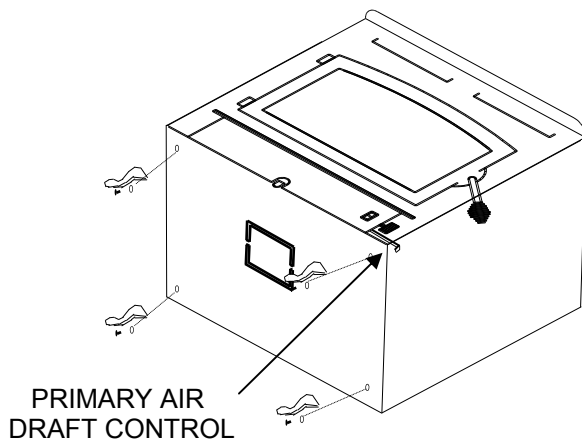

Figure 20

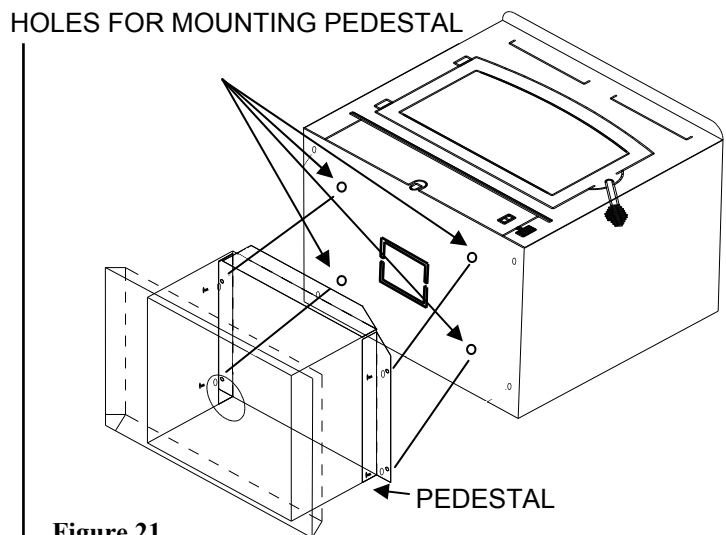

Figure 21

Chimney

This model is designed for connection to any listed 2100° UL103 HT chimneys and parts. Follow chimneys manufacturer's instructions carefully.

This room heater must be converted to (1) a chimney complying with the requirements for Type HT chimneys in the Standard for chimneys, Factory-Built, Residential, Type and Building Heating Appliance, UL 103, or (2) a code approved masonry chimney with a flue liner.

Floor Protection:

Floor protection must be 3/8” minimum thickness non-combustible material or equivalent.

How to use alternate materials and how to calculate equivalent thickness

An easy means of determining if a proposed alternate floor protector meets requirements listed in the appliance manual is to follow this procedure:

1. Convert specification to R-value:
 - R-value is given—no conversion is needed.
 - K-factor is given with a required thickness (T) in inches:
 - C-factor is given: $R=1/C$
2. Determine the R-value of the proposed alternate floor protector.
 - Use the formula in step (1) to convert values not expressed as “R”
 - For multiple layers, add R-values of each layer to determine the overall R-value.
3. If the overall R-value of the system is greater than the R-value of the specified floor protector, the alternate is acceptable.

Example:

The specified floor protector should be 3/4” thick material with a K-factor of 0.84.

The proposed alternate is 4” brick with a C-factor of 1.25 over 1/8” mineral board with a K-factor of 0.29.

Step (a): Use formula above to convert specification to R-value. $R= 1/K \times T = 1/0.84 \times .75 = 0.893$

Step (b): Calculate R of proposed system. 4” brick of $C=1.25$, therefore $R_{brick} = 1/C = 1/1.25 = 0.80$ 1/8” mineral board of $K = 0.29$, therefore $R_{min.bd.} = 1/0.29 \times 0.125 = 0.431$

Step (c): Compare proposed system R of 1.231 to specified R of 0.893. Since proposed system R is greater than required, the system is acceptable.

Definitions:

$$\text{Thermal conductance} = C = \frac{\text{Btu}}{(\text{hr})(\text{ft}^2)(\text{°F})} = \frac{\text{W}}{(\text{m}^2)(\text{°K})}$$

$$\text{Thermal conductance} = K = \frac{(\text{Btu})(\text{inch})}{(\text{hr})(\text{ft}^2)(\text{°F})} = \frac{\text{W}}{(\text{m})(\text{°K})} = \frac{(\text{Btu})}{(\text{hr})(\text{ft})(\text{°F})}$$

$$\text{Thermal conductance} = R = \frac{(\text{ft}^2)(\text{hr})(\text{°F})}{\text{Btu}} = \frac{(\text{m}^2)(\text{°K})}{\text{W}}$$

Install in accordance with 24 CFR, Part 3280 (HUD).

HOW TO LOCATE CHIMNEY EXIT, AND INSTALL

Alcove Installation

Vertical Exit using (6" DVL Close Clearance pipe and any Listed 2100° UL 103 HT chimney).

With optional close clearance shield and pipe shield. NOTE: For installation of optional close clearance shields and pipe shield (See Page 33).

NOTE: For minimum clearances (See Page 32, Figure 22).

1. Suspend a plumb bob from the ceiling above the unit so that the weight is hanging in the center of the flue exit. (A small weight on a string will serve as a plumb bob). Mark the ceiling where the string is suspended to locate the center of the chimney.
2. After locating the center of the hole, install the ceiling support box, chimney or chimney connector, flashing, and rain cap per the chimney manufacturer's instructions, and local building codes for installation through combustible walls or ceilings.
3. Now connect the stove and ceiling support box using DVL close clearance pipe. Connect each section per manufacturer's instructions. Secure each section to each other using minimum (3) sheet metal screws or rivets. DVL close clearance is to be connected with (3) sheet metal screws or rivets to connector collar on heater.(See Page 27,Figure 19B).

ALCOVE INSTALLATION AND CLEARANCES

**Vertical exit using (6" DVL Close Clearance pipe and
any listed 2100° UL 103 HT. TYPE Chimney).
With optional close clearance shield and pipe shield.
Model 21 minimum clearance to combustibles.**

Figure 22

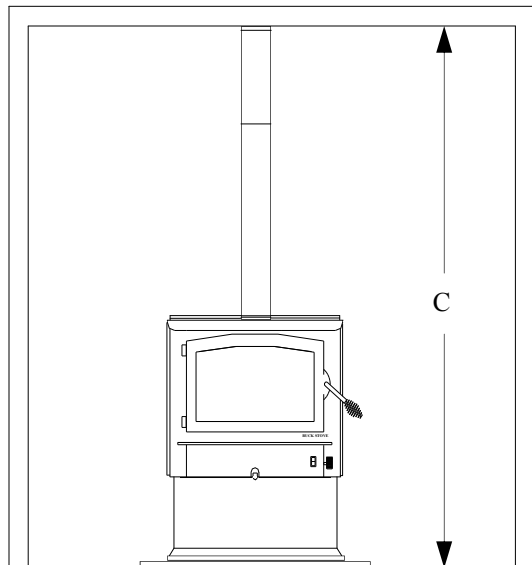
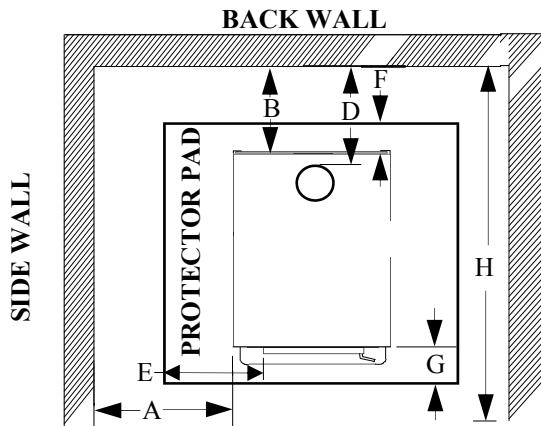

A B C D E F G H

MODEL 21 19" 7" 84" 8.5" 8" 6" 16" 48"

Figure 23

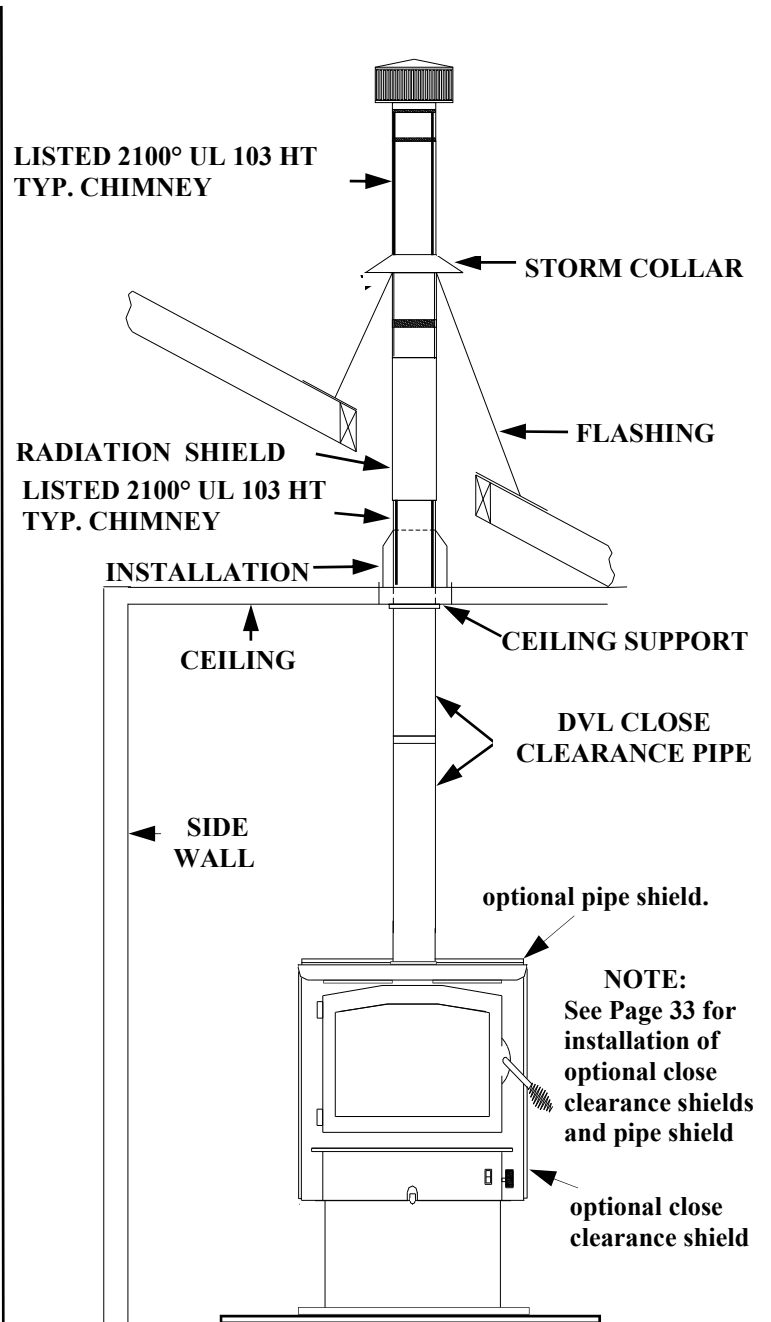

NOTE: All clearances are to combustibles with optional close clearance shields, and pipe shield, using DVL Close Clearance pipe, and minimum floor protector.

Installation of (Optional) Close Clearance Shields and Pipe Shield

1. Taking close clearance side shields, hold up to side of stove leaving 1/4" gap between shield and top of stove.
2. Make reference mark in center of pre-punched hole in top & bottom of shield. Drill two (2) 3/32" holes in back of unit on each side. Insert self tapping screws in through shield into stove.(SEE PICTURE BELOW)
3. Drill two (2) 3/16" holes in the sides of the stove where the shield meets the front side. Insert two (2) 3/8" self-tapping screws. (SEE PICTURE BELOW)
4. Next loosen two (2) top screws holding side shield at rear top. Insert pipe shield where back shield and top rear side shield meets. Leave a 1" gap from the top of stove to the pipe shield, tighten screws.(SEE PICTURE BELOW)

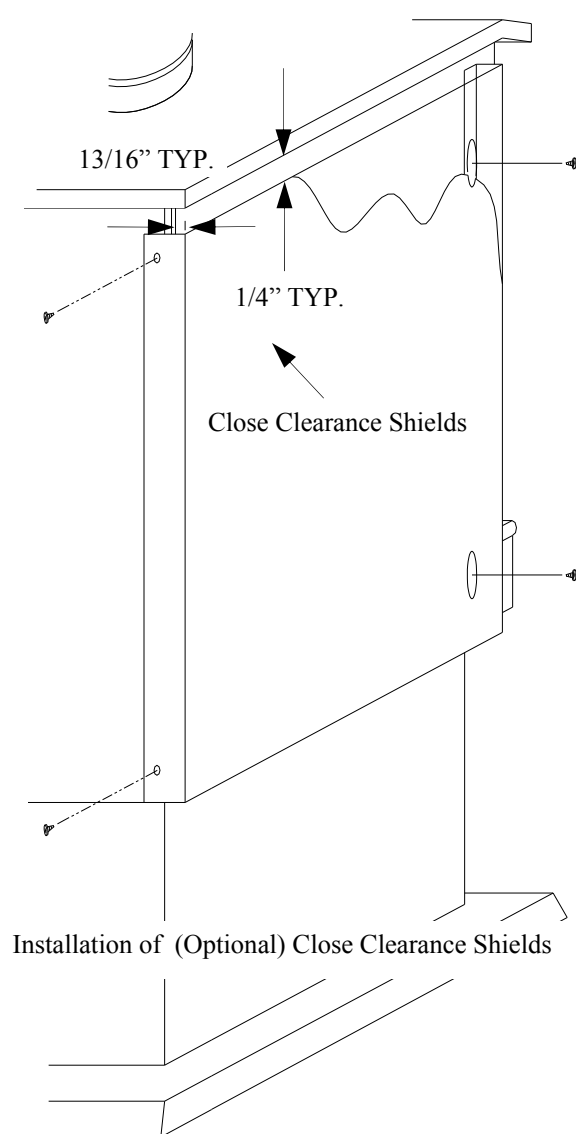
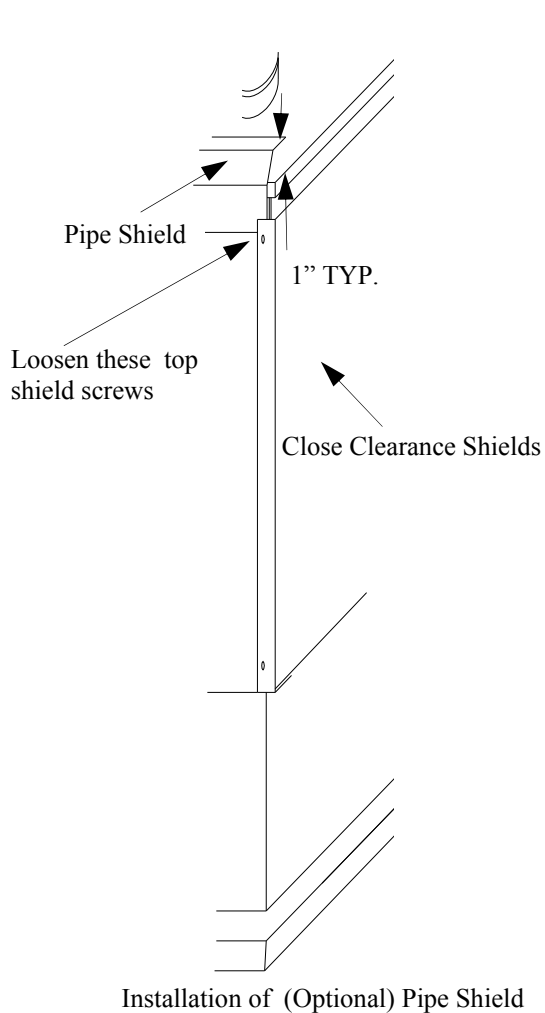

FINAL CHECK

1. Recheck the specified clearances.
2. Remove all foreign material from the firebox area.
3. Open the primary air draft.
4. Plug the power cord into a 115V AC outlet when using with optional motor. “Do not run power cord under unit or in high traffic areas”.
5. Place crumpled pieces of newspaper in the stove. Light it and close the doors. Ensure that the stove draws properly through the primary draft.
6. Check for smoke leaks around the door.

CAUTION

Open the doors and check for smoke escaping from the front of the stove. Smoking usually indicates a defective or poorly positioned chimney. Some chimneys with a marginal draft can be preheated by lighting newspaper and holding it near the open damper with a poker or fire tong. Once the chimney heats up, a proper draft can usually be obtained.

If a thorough review of the Troubleshooting Guide in the rear of the manual does not reveal the problem, contact your dealer for assistance.

CAUTION

The unit is painted with a specially formulated high temperature paint that cures during the first two or three firings. You may notice a slight smoking effect and an odor of burning paint when you build the first fires. This is normal and is not a cause for alarm. In some cases, these fumes will activate a smoke alarm. Opening a window near the unit will allow these fumes to escape. DO NOT build a large, roaring fire until this curing is complete or the heater finish may be damaged.

SECTION VI

WOOD HEATER SAFETY

Certain safety hazards are inherent in any wood heater installation. You should be aware of these so that a safe and proper installation can be made.

1. **FAULTY CHIMNEY:** An older masonry chimney should be thoroughly checked to be sure there are no holes or weak spots which could allow sparks or hot gases to escape.
2. **HEAT CONDUCTION:** Placing combustible materials too close to a heater or chimney can be a fire hazard.

By keeping these particular hazards in mind as you install and use your room heater you can ensure a safe, reliable installation.

The chimney and chimney connector should be inspected once every two months. Any build-up of soot should be removed to prevent the risk of a chimney fire. To remove chimney or chimney connector: Remove screws or fasteners. Remove pipe and clean with steel brush. Replace chimney or chimney connector, and replace screws and/or fasteners.

CAUTION

NEVER USE GASOLINE, GASOLINE TYPE LANTERN FUEL, KEROSENE, CHARCOAL LIGHTER FLUID OR SIMILAR LIQUIDS TO START OR "FRESHEN UP" A FIRE IN THE HEATER. KEEP ALL SUCH LIQUIDS WELL AWAY FROM THE STOVE WHEN IT IS IN USE. ALL FLUIDS OF THIS TYPE GIVE OFF VOLATILE FUMES AND CAN AND WILL EXPLODE!! DON'T TAKE A CHANCE WITH THE SAFETY OF YOUR HOME AND FAMILY.

CAUTION: Never remove ashes from heater with blower running.

DISPOSAL OF ASHES: Ashes should be placed in a metal container with a tight fitting lid. The closed container of ashes should be placed on a non-combustible floor or on the ground, well away from all combustible materials pending final disposal. If the ashes are disposed of by burial in soil or otherwise locally dispersed, they should be retained in the closed container until all cinders have thoroughly cooled.

CREOSOTE-FORMATION AND NEED FOR REMOVAL: When wood is burned slowly, it produces tar and other organic vapors, which combine with expelled moisture to form creosote. The creosote vapors condense in the relatively cool chimney flue of a slow-burning fire. As a result, creosote residue accumulates on the flue lining. When ignited this creosote makes an extremely hot fire.

SECTION VII OPERATION

This section of the manual is to help you get the maximum efficiency and maximum smoke (particulate) reduction from your heater. If you should experience any difficulty or have any questions concerning your heater, contact your dealer for assistance. The manufacturer recommends that for maximum performance burn dried natural seasoned hard wood.

Build a fire for maximum efficiency. These models burn wood and extract heat so efficiently, a large fire is not necessary. A large fire not only wastes energy, it usually results in the home being too warm for comfort.

The following steps will serve as a guide for operating your stove.

BUILDING A FIRE

1. Open the door.
2. Open the primary air control under hearth, push in. To close pull all the way out.
3. Twist two pieces of non-colored newspaper into a roll and place them on the floor of the firebox.
4. These models are not designed for the use of grates, andirons or other methods of supporting the fuel.

NOTE: “Do not use grate or elevate fire. Build wood fire directly on inner bottom of fire box.”

5. Lay several pieces of dry kindling on top of the newspaper.
6. Place three or four small pieces of firewood, 2-3" in diameter, on top of the kindling.
7. Light the newspaper in the front. Close and latch the door. Don't leave the fire unattended at this point. The draft system of the heater should start quickly. It may be necessary to preheat the chimney to get the draft started. To do this, open the door and add newspaper to the top rear of the wood. Light or let this paper ignite and allow to burn while holding the door slightly cracked. Once the draft has started, close and lock the door. You are over heating the unit if the chimney and or connector glows red.
8. **After embers and a coal bed have been established, load the heater with dried natural seasoned hard wood.**

NOTE: THE FUELING DOOR MUST REMAIN CLOSED DURING OPERATION.

NOTE: If the optional blower is being used on the Model 21. Your stove is equipped with a automatic thermostat. When the stove gets hot enough, the thermostat will activate the room air blower. Set fan speed according to desired heat output.

NOTE: When refueling or removing ashes turn “OFF” room air blower. Be sure to turn room air blower back on when finished.

NOTE: Do not run power cord underneath heater or in walk way or heavy traffic areas.

SECTION VIII TROUBLESHOOTING

PROBLEM	POSSIBLE CAUSE	SOLUTION
Sluggish Heater	Obstruction in chimney	Check for and remove obstruction
	Improperly sealed trim kit or direct connect kit	(a) Check trim kit gasketing seal to fireplace and gasket as necessary to seal unit. Gasket under front bottom of stove if needed. (b) Check seal if using direct connect and correct.
	Manual damper in chimney is closed	Open manual damper and wire shut with stainless steel wire or remove damper
	Wet or unseasoned wood being burned	Burn dried natural seasoned hard wood
	Poor chimney draft	Improper chimney height or wrong size flue is being used. Cooler temperatures caused by external chimney

PROBLEM	POSSIBLE CAUSE	SOLUTION
High fuel consumption	Improper regulation of draft or inlet air	(a) Close inlet air control as much as possible to maintain desired heat output (b) Check gaskets, reinstall fiberglass gasketing round doors and glass as necessary
	Improper door fitting	Check door gasket, check adjustment of door latch
Backpuffing	Gusts of Wind	(a) Smoke shelf in chimney is filled with creosote & ash (b) Chimney may need wind diverter. Raise chimney for better draft
Smoke rollout when heater door is opened	Wind gusts blowing down the chimney	(a) Smoke shelf in chimney is filled with creosote & ash (b) Chimney may need wind diverter. Raise chimney for better draft
	Opening heater door too fast	Crack door for 15 seconds before fully opening door

NEW BUCK CORPORATION (NBC)
"LIMITED WARRANTY" FOR THE BUCK STOVE
PLEASE READ THIS WARRANTY CAREFULLY

PRODUCTS COVERED

This warranty covers the new Buck Stove heating unit, so long as it is owned by the original purchaser, including optional and standard accessories purchased at the same time, subject to terms, limitations, and conditions herein set out.

PRODUCTS NOT COVERED

This warranty does not cover the following:
Glass, Refractory material or firebrick, Gaskets.

This Warranty will not cover any damage and/or failure caused by abuse or improper installation of the products covered.

WARRANTY TIME PERIODS

(A) Period I

For one year from the date of purchase, NBC will replace or repair, at its option, any part defective in materials or workmanship. The costs of parts only are included. The customer pays any labor or transportation charges required.

Thereafter,

(B) Period II

For the period after the first year from the date of purchase and extending for five years as long as the Buck Stove is owned by the original purchaser, NBC will repair or replace, at its option, any part defective in materials or workmanship, with the exception of: electrical motors, wiring, switches, and components: optional and standard accessories; and all parts not permanently attached to the heating unit. Parts not permanently attached to the heating unit are defined as those items designed to be removed from the stove, including those removable with common hand tools. The costs of parts only are included. The customer pays any labor or transportation charges required.

PROCEDURE

Should you feel that your BUCK STOVE is defective, you should contact any Buck Stove dealer for the name of your nearest authorized Buck Stove service representative, who will instruct you on the proper procedure, depending on which Warranty Time Period (Period I or Period II) applies.

If for any reason you are dissatisfied with the suggested procedures, you may contact us in writing at:

New Buck Corporation
Customer Service Department
P. O. Box 69
Spruce Pine, NC 28777

CONDITIONS AND EXCLUSIONS

- (A) Replacement of parts may be in the form of new or fully reconditioned parts, at NBC's option.
- (B) There is no other express warranty. All implied warranties of merchantability and fitness for use are limited to the duration of the Express Warranty.
- (C) New Buck Corporation is not liable for indirect, incidental, or consequential damages in connection with the use of the product including any cost or expense of providing substitute equipment or service during periods of malfunction or non-use. Some states do not allow the exclusion of incidental or consequential damages, so the above exclusion may not apply to you.
- (D) All warranty repairs under this warranty must be performed by an authorized Buck Stove service representative. Repairs or attempted repairs by anyone other than an authorized service representative are not covered under this warranty. In addition, these unauthorized repairs may result in additional malfunctions, the correction of which is not covered by warranty.

OTHER RIGHTS

This warranty gives you specific legal rights, and you may also have other rights, which vary from state to state.

OWNER REGISTRATION CARD

The attached Owner Registration Card must be completed in its entirety and mailed within 30 days from the date of purchase or from the date of installation, if installed by a factory certified installer, to New Buck Corporation in order for warranty coverage to begin.

PLEASE NOTE: The Owner Registration Card must contain the Authorized Buck Stove Dealer Code Number and the Certified Installer's number (if applicable) for warranty coverage to begin.

To be completed by selling distributor or dealer for customer:

Warranty Card Not Available On Web & Replacement Versions