

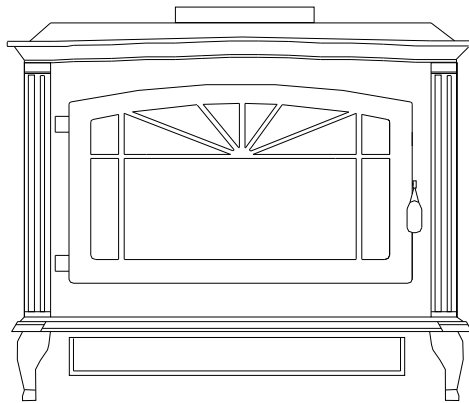

MODEL 21 CAST IRON INSERT/ TOWNSEND III

NON-CATALYTIC/FREESTANDING ONLY/ROOM HEATER
ALSO SUITABLE FOR MOBILE HOME INSTALLATION/
(MOBILE HOME INSTALLATION KIT AND INSTRUCTIONS MUST BE
PURCHASED SEPARATE)



TESTED AND LISTED BY:
ITS/WARNOCK HERSEY,

Warnock Hersey



MIDDLETOWN, WI

Approved June, 2003

SAFETY NOTICE

FEATURES

PREPARATIONS

INSTALLATION

OPERATION

MAINTENANCE

SAFETY

WARNING: IF THIS HEATER IS NOT PROPERLY INSTALLED, A HOUSE FIRE MAY RESULT. FOR YOUR SAFETY, FOLLOW THE INSTALLATION INSTRUCTIONS EXACTLY. CONTACT LOCAL BUILDING OR FIRE OFFICIALS CONCERNING RESTRICTIONS AND INSTALLATION INSPECTIONS IN YOUR AREA.

MANUFACTURED BY: NEW BUCK CORPORATION

P.O. BOX 69

SPRUCE PINE, NC 28777

TABLE OF CONTENTS

Important Instructions	3
Introduction.....	4
Residential Freestanding Installation.....	6
Ceiling Exits.....	8
Floor Protection	9
Chimney Location.....	9
Wall Exits.....	10
Alcove Installation Clearances	13
Mobile Home Freestanding Installation.....	16
Wood Heater Safety.....	18
Operation.....	19
Ash Removal Instructions.....	20
Optional Room Air Blower Installation.....	21
Wiring Diagram	22
Trouble Shooting	23
Warranty	24

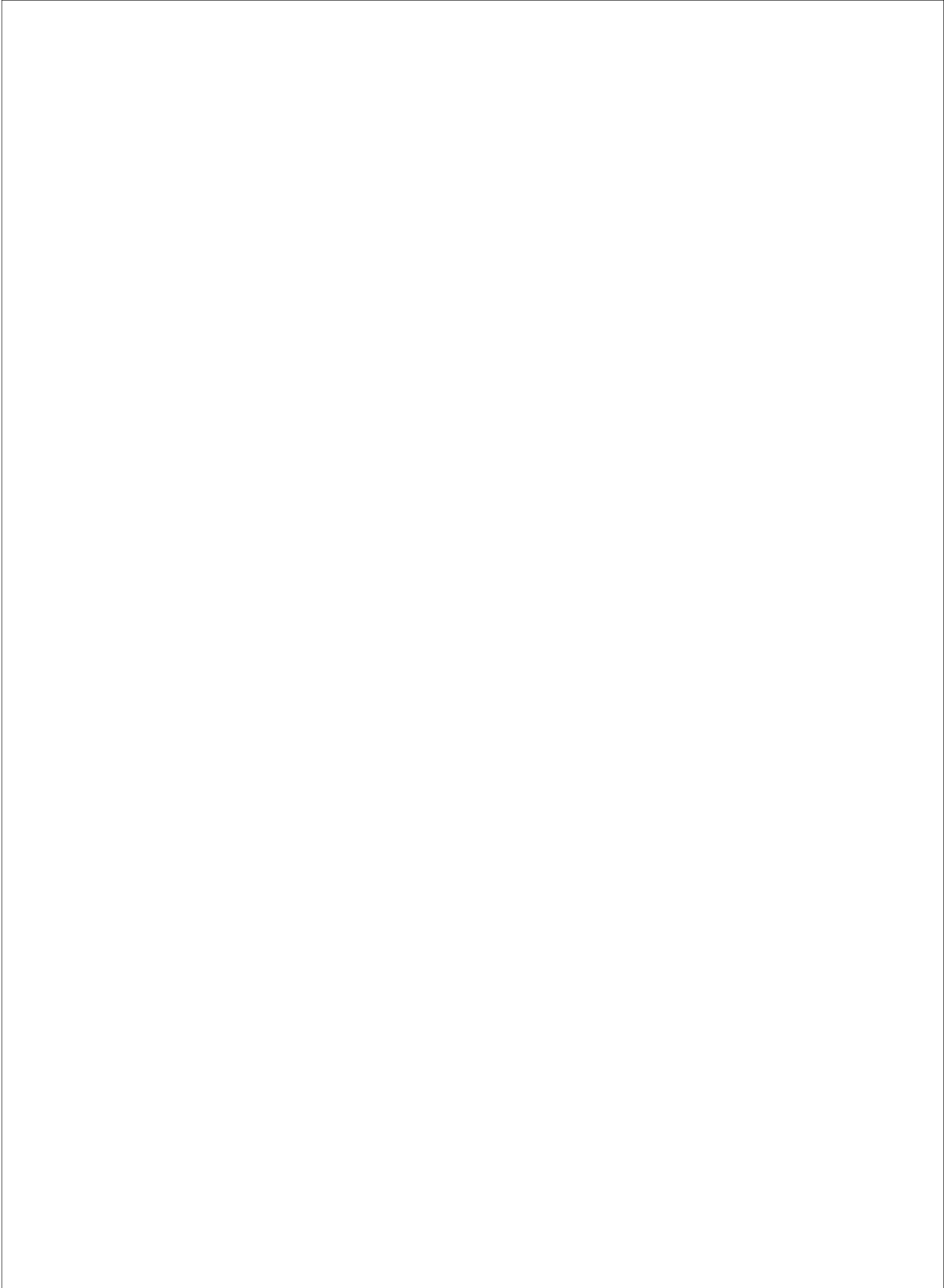

MODEL 21CAST IRON INSERT/ TOWNSEND III

READ THIS FIRST

IMPORTANT INSTRUCTIONS

WARNING

THESE UNITS GENERATE A LOT OF HEAT, SO TREAT THEM WITH CARE. **HOT WHILE IN OPERATION!** KEEP CHILDREN, CLOTHING AND FURNITURE AWAY. CONTACT MAY CAUSE SKIN BURNS. READ ALL INSTRUCTIONS BEFORE INSTALLING AND USING THE APPLIANCE. FAILURE TO FOLLOW INSTRUCTIONS MAY RESULT IN PROPERTY DAMAGE, BODILY INJURY, OR EVEN DEATH. SAVE THESE INSTRUCTIONS FOR FUTURE REFERENCES.

- The New Buck Corp. Model 21 Cast Iron Insert/Townsend III has been tested by ITS, Warnock Hersey to ANSI/UL Standards 1482.
- Install and operate according to instructions provided in this manual. Local building codes may apply; therefore, contact your local building inspector or fire marshal for necessary installation requirements and permits which may go beyond these instructions.
- **If appliance is installed in a Mobile Home: “DO NOT INSTALL IN SLEEPING ROOMS.”**
- The Model 21 Cast Iron Insert/Townsend III is not approved for use in Zero Clearance fireplaces (ZCF’s).
- This wood burning room heater is Freestanding only .

CAUTION

DO NOT USE MORE THAN ONE STOVE TO A CHIMNEY. DO NOT USE A FLUE INTENDED FOR A GAS APPLIANCE.

- A factory-built prefabricated chimney may be used for your unit when installed in compliance with the manufacturer's specification and uniform building code.

CAUTION

YOUR CHIMNEY MUST BE CORRECTLY SIZED. A CHIMNEY THAT IS TOO SMALL OR LARGE IN DIAMETER, OR TOO SHORT, CAN CAUSE YOUR STOVE TO SPILL SMOKE WHEN THE DOOR IS OPENED.

SECTION I

INTRODUCTION

Your New Buck Corp. Model 21 Cast Iron Insert/Townsend III is a non-catalytic unit designed to meet the most stringent emissions standards without the use of a catalytic combustor. This effect is achieved through the use of secondary air which is mixed with primary air in the unit's firebox. **For peak performance, we suggest the use of hard seasoned wood.**

The primary air, which is controlled by the user, burns the wood. Secondary air is admitted into the firebox through the secondary air tubes at the top of the firebox. This secondary air burns the impurities in the smoke released from the initial wood burning. The temperature necessary for this combustion is maintained through the firebrick refractory. If any more technical information is necessary, contact your local dealer.

This unit may also be used with an **optional** room air blower. To order the **optional** motor assemblies you must specify the stove model number and give the following part number:

*Model 21 Cast Iron Insert /Townsend III Motor Assembly — MA T3714

CAUTION

THE UNIT IS PAINTED WITH A SPECIALLY FORMULATED HIGH TEMPERATURE PAINT THAT CURES DURING THE FIRST TWO OR THREE FIRINGS. YOU MAY NOTICE A SLIGHT SMOKING EFFECT AND AN ODOR OF BURNING PAINT WHEN YOU BUILD THE FIRST FIRES. THIS IS NORMAL AND IS NOT A CAUSE FOR ALARM. IN SOME CASES, THESE FUMES WILL ACTIVATE A SMOKE ALARM. OPENING A WINDOW NEAR THE UNIT WILL ALLOW THESE FUMES TO ESCAPE. DO NOT BUILD A LARGE, ROARING FIRE UNTIL THIS CURING IS COMPLETE OR THE HEATER FINISH MAY BE DAMAGED.

The connector and/or chimney should be inspected at least once a month during the heating season to determine if a creosote buildup has occurred.

CAUTION

NEVER USE GASOLINE, GASOLINE-TYPE LANTERN FUEL, KEROSENE, CHARCOAL LIGHTER FLUID OR SIMILAR LIQUIDS TO START OR "FRESHEN UP" A FIRE IN THE HEATER. KEEP ALL SUCH LIQUIDS WELL AWAY FROM THE STOVE WHEN IT IS IN USE. ALL FLUIDS OF THIS TYPE GIVE OFF VOLATILE FUMES AND CAN AND WILL EXPLODE!! DON'T TAKE A CHANCE WITH THE SAFETY OF YOUR HOME AND FAMILY.

SECTION II

RESIDENTIAL FREESTANDING INSTALLATION

PREPARING THE STOVE FOR INSTALLATION

The Model 21 Cast Iron Insert/Townsend III is made up of a steel firebox installed into a cast iron outer housing. The assembly of these parts are completed by the manufacturer. The following assembly steps must be completed by the installer.

1. Lift off corrugated box enclosing stove body crating. Remove plastic bag from stove body.
2. Inspect the unit for any obvious physical damage.
3. Open the firebox door and remove all contents from inside the firebox area (except the fire brick). Contents include:
 - A. Legs with leg leveler bolts
 - B. Bottom access door with hardware
 - C. Top grates (3)
 - D. Door handle
 - E. Instruction Manual
 - F. Hearth with hardware
 - G. Air Control Assembly with hardware
 - H. Allen Wrench
4. Spread a thick blanket on the floor behind the heater to protect the floor. Next, tilt the heater so that the back is on the drop blanket (See Figure 1). **NOTE:** The heater is heavy and may require two (2) people to lift.
5. Carefully lay the heater on its back and remove the pallet from the bottom of the heater (See Figure 1) to attach the bottom components.
6. Fasten each leg with the four (4) M8 x 1.25-20 mm bolts provide. Use a flat washer with each bolt. Tighten bolts into threaded holes on the cast stove (body) housing. Next attach the hearth to the cast stove body using the (2) two brackets provided and the (4) bolts provided (See Figure 2).

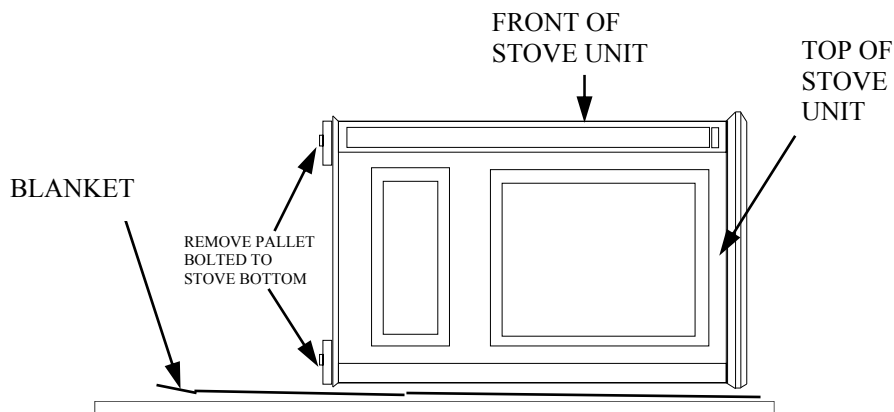
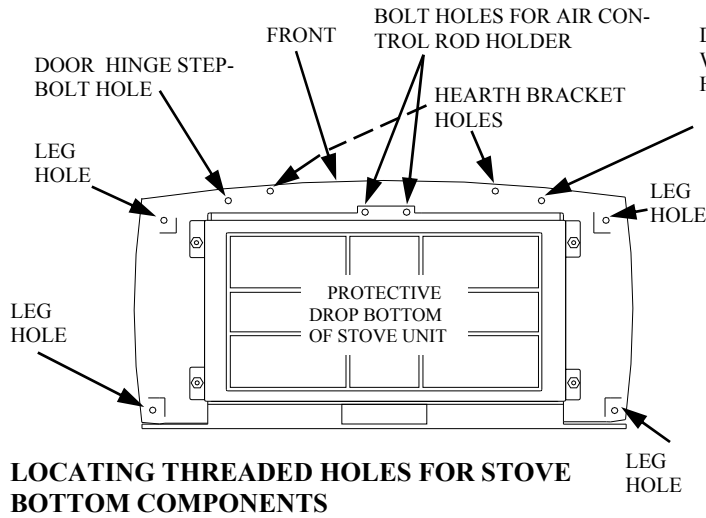

FIGURE 1 - LAYING DOWN STOVE ON SIDE



DOOR CATCH BOLT WITH ADJUSTABLE HEX NUTS HOLE

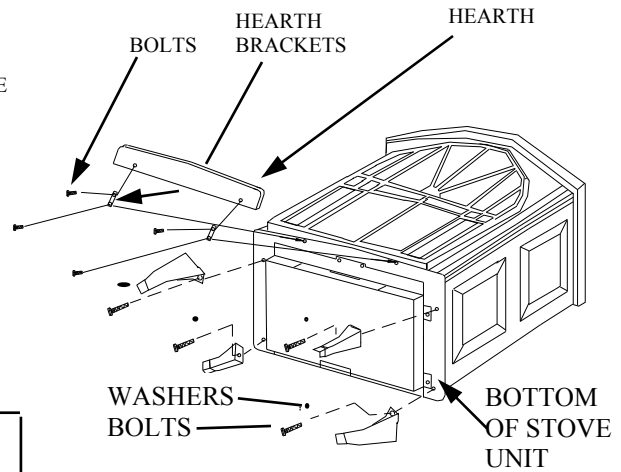

FIGURE 2

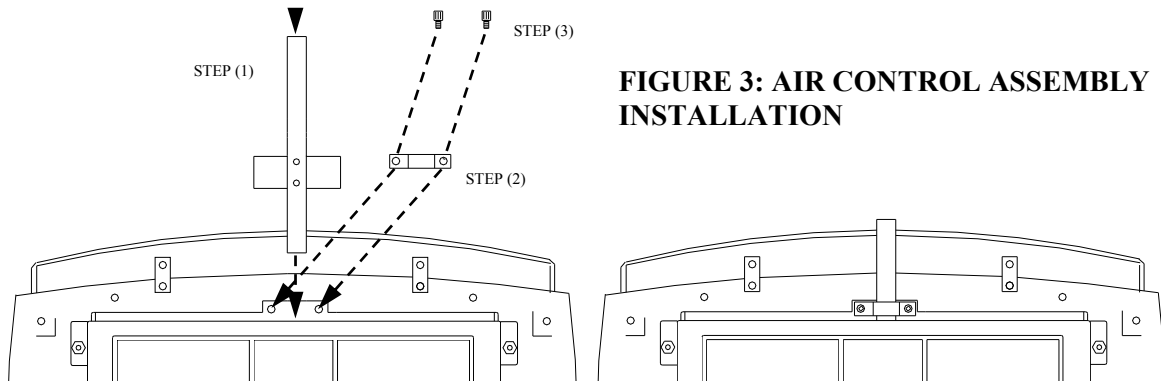
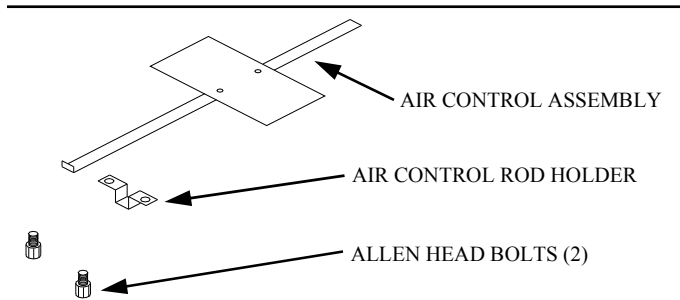

FIGURE 3: AIR CONTROL ASSEMBLY INSTALLATION

7. Locate the Air Control assembly and hardware provided.
8. Follow the steps in figure 3 to install the Air Control assembly.
9. Attach the access cover door by inserting the step bolt through the door hinge pivot hole (See Figure 4) and into the threaded hole (See Figure 4) in the bottom of the front of the cast housing. Use an adjustable wrench or a 12 mm socket to fasten the step bolt. Tighten the step bolt until snug. Make sure the door moves freely.
8. Next install the door catch bolt (M8 x 1.25-55 mm with two (2) M8 hex nuts) (see Figure 4) into the threaded hole located on the front bottom of the cast housing (See Figures 2 and 4). Use an adjustable wrench or a 12mm socket. The catch bolt has two (2) hex nuts attached to it (See Figure 5). The top nut is a bolt stop and the bottom nut is for the door leveling adjustment.
9. Check general catch bolt alignment with door claw. Make final adjustment and door leveling after stove is in normal standing position.

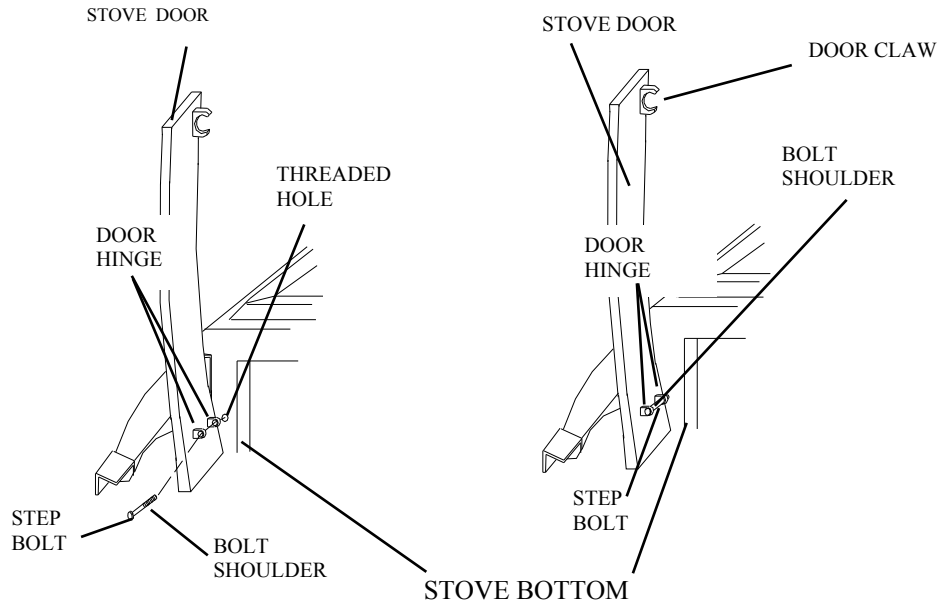

Figure 4-Attaching Lower Stove Door Panel

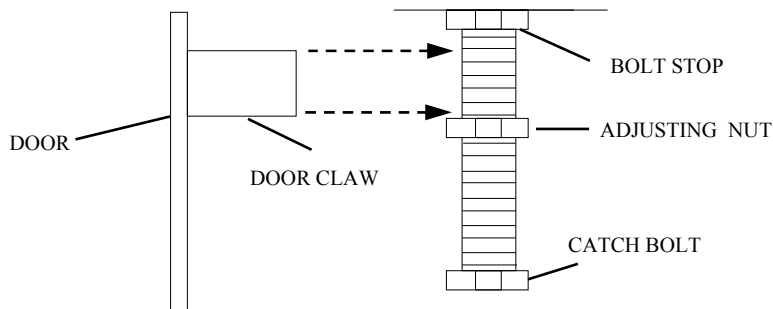

FIGURE 5 - CATCH BOLT AND DOOR CLAW ORIENTATION

12. After returning the heater (stove) to its upright position, place the heater in the location desired. **NOTE:** Check section in this Operations/Installation Manual for Clearances to Combustibles.

CHIMNEY

Ceiling Exits:

This heater is designed for connection to:

- | | |
|--------------------------|-----------------|
| (1) Simpson Duravent | (4) Metal Fab |
| (2) Security | (5) Airjet |
| (3) Selkirk Metal Bestos | (6) Jakes Evans |

listed at 2100 deg. pipe and parts. Follow pipe manufacturer's instructions carefully.

This room heater must be converted to (1) a chimney complying with the requirements for Type HT chimneys in the standard for chimneys, Factory-Built, Residential, Type and Building Heating Appliance, UL 103, or (2) a code approved masonry chimney with flue liner.

CAUTION

Special methods are required when passing through a wall or ceiling. See instructions and building codes.

FLOOR PROTECTION:

If this heater is to be installed on a combustible floor, a non-combustible pad must be placed below it to protect the floor from burning material from the heater. The pad must be 39" wide and 40" deep. A UL tested floor protector with a 3/8" minimum thickness, non-combustible material or equivalent, must be used.

The heater must be positioned on the pad so that there is a minimum of 16" from the front of the door opening to the front of the pad, and a minimum of 6" measured horizontally from the sides of the heater.

DETERMINING THE CHIMNEY LOCATION

A. CEILING EXIT (Using Single Wall Pipe and UL 103 HT type chimney system listed with manufacturer in this section of manual.)

1. Suspend a plumb bob from the ceiling above the unit so that the weight is hanging in the center of the flue exit (See Figure 6). (A small weight on a string will serve as a plumb bob.) Mark the ceiling where the string is suspended to locate the center of the chimney.
2. After locating the center of the hole, install the ceiling support box, chimney flashing and rain cap per the chimney manufacturer's instructions.
3. Now connect the stove and ceiling support box using #24 ga. minimum blued or black steel connector pipe (**DO NOT USE GALVANIZED PIPE**). Connect each section so the crimped end faces downward, and secure each section to each other using at least three (3) sheet metal screws or rivets. Also use three (3) sheet metal screws to fasten pipe to collar on heater. (See Figure 7.)

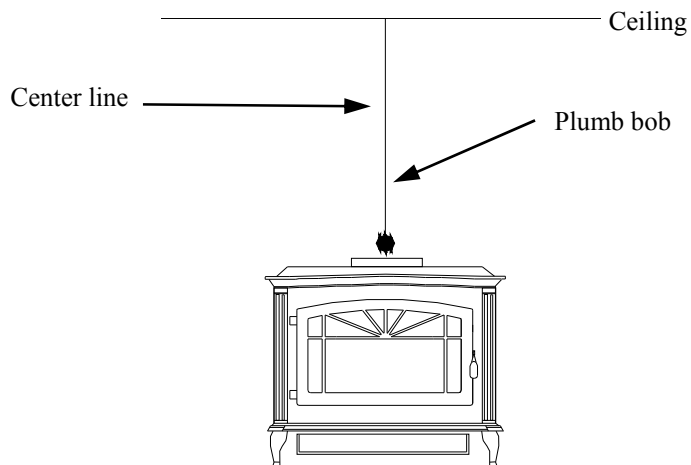

Figure 6

NOTE: See Chimney Manufacturers Installation Instructions For Installing Chimney and Ceiling Trim Plate.

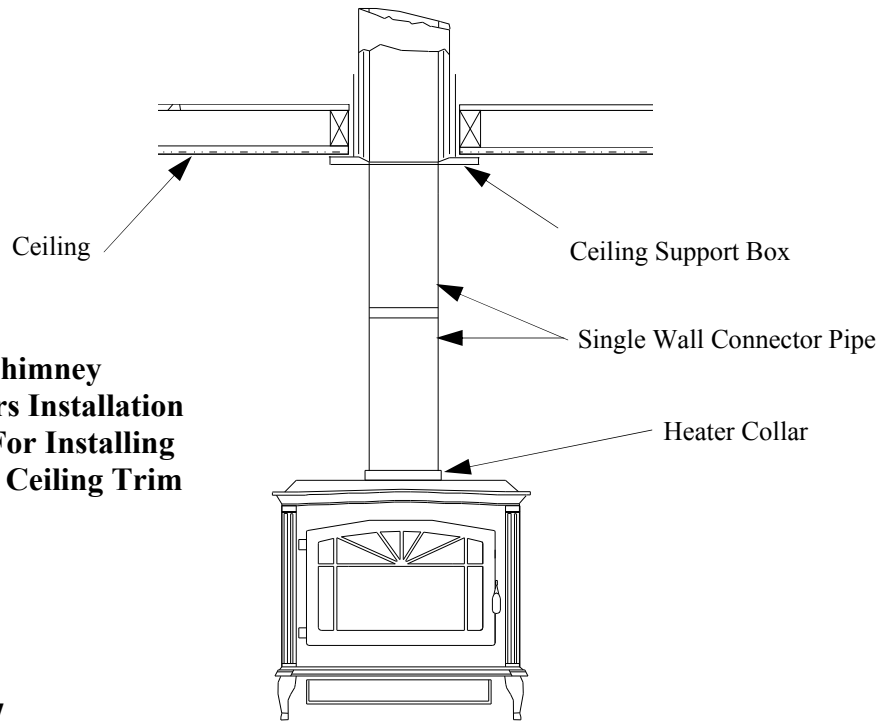

Figure 7

B. Wall Exit Into Metal Tee-Box

1. Mark the plumb line on the wall directly behind the center of the heater. (See Figure 7.)

NOTE: When using 24# ga. minimum blue or black steel pipe, maintain 18" between pipe and ceiling.

2. Place the vertical portion of the heater pipe and the elbow in position and project a point onto the plumb line level with the center of the elbow.
3. Measure up so there will be at least 1/4" rise per foot of horizontal connector pipe, maintaining clearances to the ceiling as noted in Figure 8. This will give you the center of the hole for the chimney penetration.
4. After locating the center of the penetration, install the tee-box and chimney as per the chimney manufacturer's specifications.
5. Connect the chimney collar to the tee-box using #24 ga. minimum blued or black steel connector pipe. **DO NOT** use galvanized pipe. Connect each section so the crimped end faces downward, and secure each section to each other using three (3) sheet metal screws or rivets.

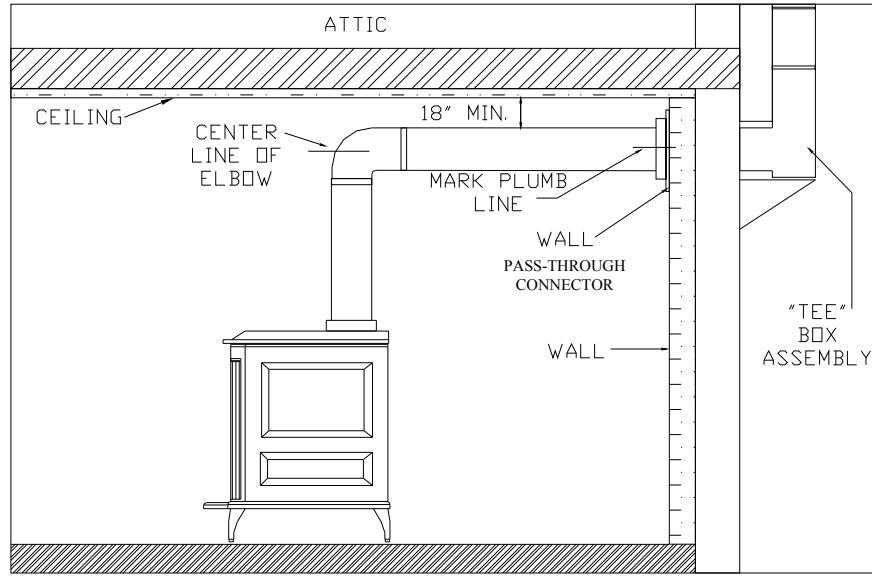

Figure 8

C. Wall Exit Into Masonry (Using Single Wall Pipe)

1. Before connecting these units to a masonry chimney, determine that the masonry fireplace wall pass-through connector thimble meets the NFPA-211 Code and local building codes and is a minimum of 18" from the ceiling. If the connector thimble does not meet these codes, the pass-through connector must be modified. (See Figure 9.)

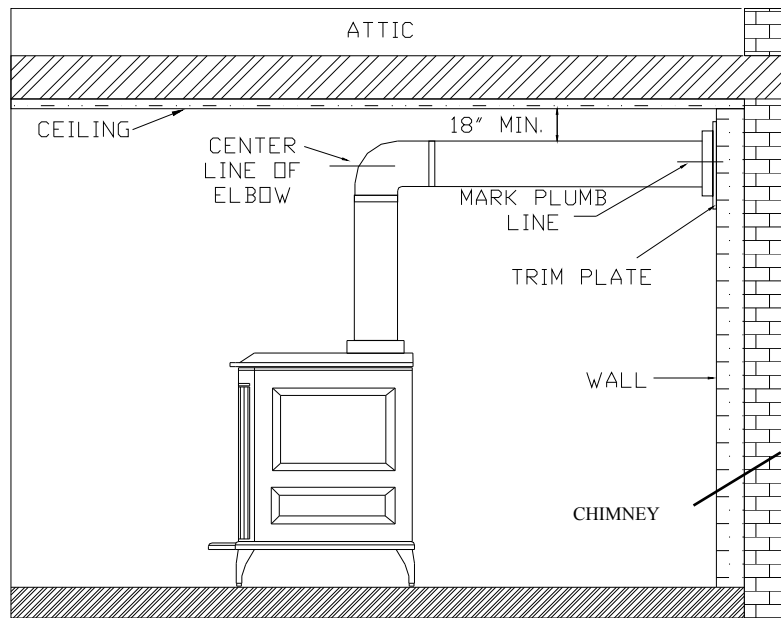

Figure 9

Connectors may pass through walls or partitions constructed of combustible material if the connector is:

- (a) Either listed for wall pass-through or is routed through a device listed for wall pass-through and is installed in accordance with the conditions of the listing.
- (b) Selected or fabricated in accordance with the conditions and clearances as stated in the **NFPA-211** Code. Any unexposed metal that is used as part of a wall pass-through system and is exposed to flue gases shall be constructed of stainless steel or other equivalent material that will resist corrosion, softening, or cracking from flue gases at temperatures up to 1800° F.

In addition, a connector to a masonry chimney shall extend through the wall to the inner face or liner but not beyond, and shall be firmly cemented to masonry.

EXCEPTION: A thimble may be used to facilitate removal of the chimney connector for cleaning, in which case the thimble shall be permanently cemented in place with high-temperature cement.

2. Once the through-the-wall thimble codes are met, simply connect the chimney collar to the wall pass-through connector using #24 ga. minimum, blued or black steel connector pipe as follows:
 - (a) Maintain 1/4" rise per foot (horizontal length) from the appliance to the chimney.
 - (b) Connect each section so the crimped end faces downward.
 - (c) Secure each section to each other using at least three (3) sheet metal screws or rivets.
 - (d) Use three (3) sheet metal screws to fasten pipe to connector collar on heater.

D. Ceiling Exit-Close Clearance

1. Suspend a plumb bob from the ceiling above the unit so that the weight is hanging in the center of the flue exit (A small weight on a string will serve as a plumb bob) (See Figure 5). Mark the ceiling where the string is suspended to locate the center of the chimney hole.
2. After locating the center of the hole, install the ceiling support box, chimney flashing and rain cap.
3. Install Double Wall Connector and chimney system per manufacturer's written operating instructions. See manufacturer's list of tested pipes in this manual (See Figure 10).

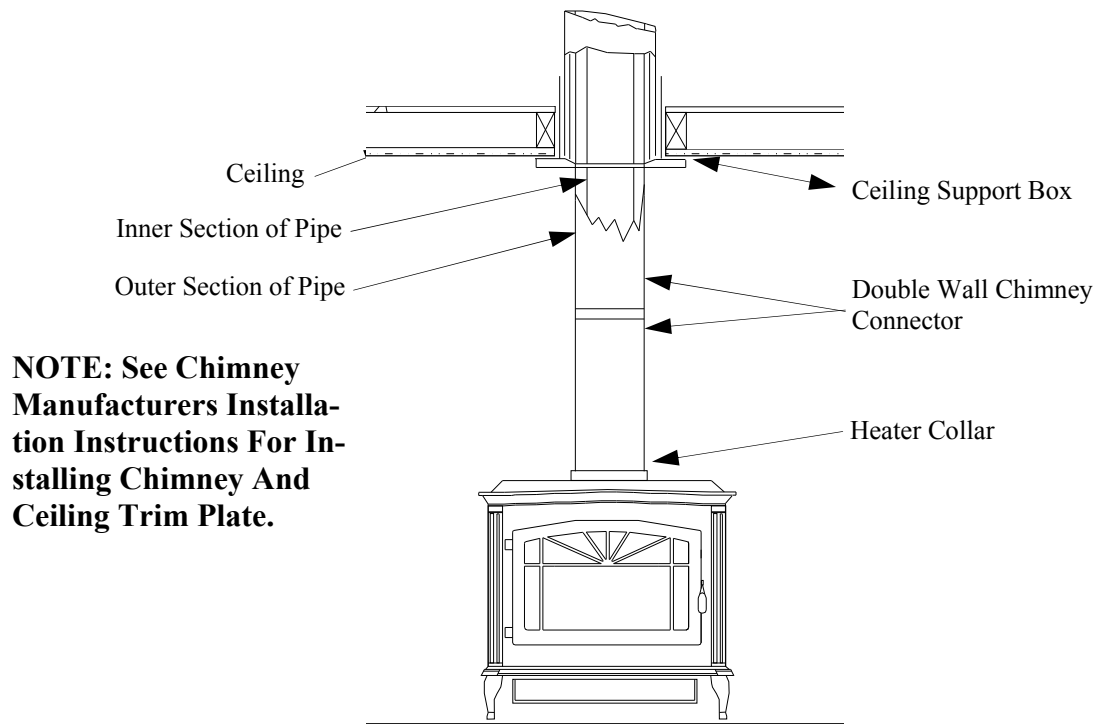

NOTE: See Chimney Manufacturers Installation Instructions For Installing Chimney And Ceiling Trim Plate.

Figure 10

Close Clearance Installation using: **(1)** 8" Simpson Dura-Vent double wall chimney connector "Type DVL" and 8" Simpson Dura-Vent 2100 Deg HT. "Type DP" chimney. **(2)** 8" Security Type DL double wall connector and 8" Security Type "ASHT" High Temp Chimney. **(3)** 8" Selkirk Metal Bestos Model "DS" double wall connector- 8" Selkirk Metal Bestos Model SSII Type HT Chimney System. **(4)** 8" Metal Fab Type "DW" double wall connector- 8" Metal Fab 2100 HT chimney. **(5)** 8" Air Jet. **(6)** Jakes Evans.

Alcove Installation Clearances

Must use 6" Double Wall Connector and 6" Type HT Pipe listed for close clearance reduction listed in this manual. For minimum clearances see page 14 .

**MINIMUM CLEARANCES TO COMBUSTIBLES (WALLS)
USING SINGLE WALL PIPE AND MINIMUM FLOOR PROTECTOR**

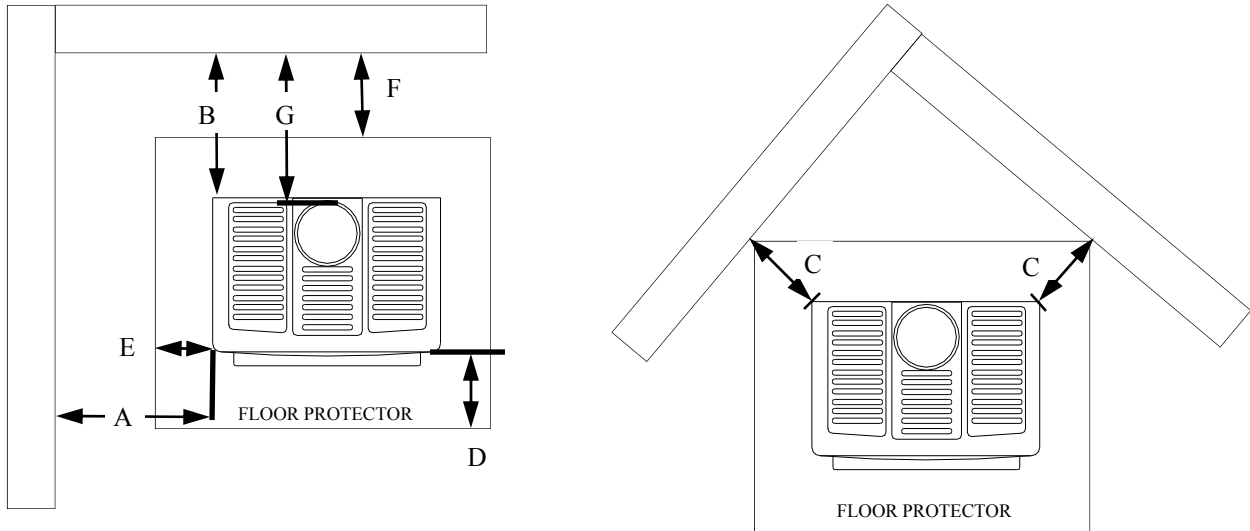

A	B	C	D	E	F	G
18"	16"	12"	16"	6"	6"	19"

Note: The clearances above may be reduced. Follow **NFPA-211** codes if available or follow instruction on the next page.

Figure 11

**MINIMUM CLEARANCES TO COMBUSTIBLES (WALLS)
USING DOUBLE WALL PIPE AND MINIMUM FLOOR PROTECTOR**

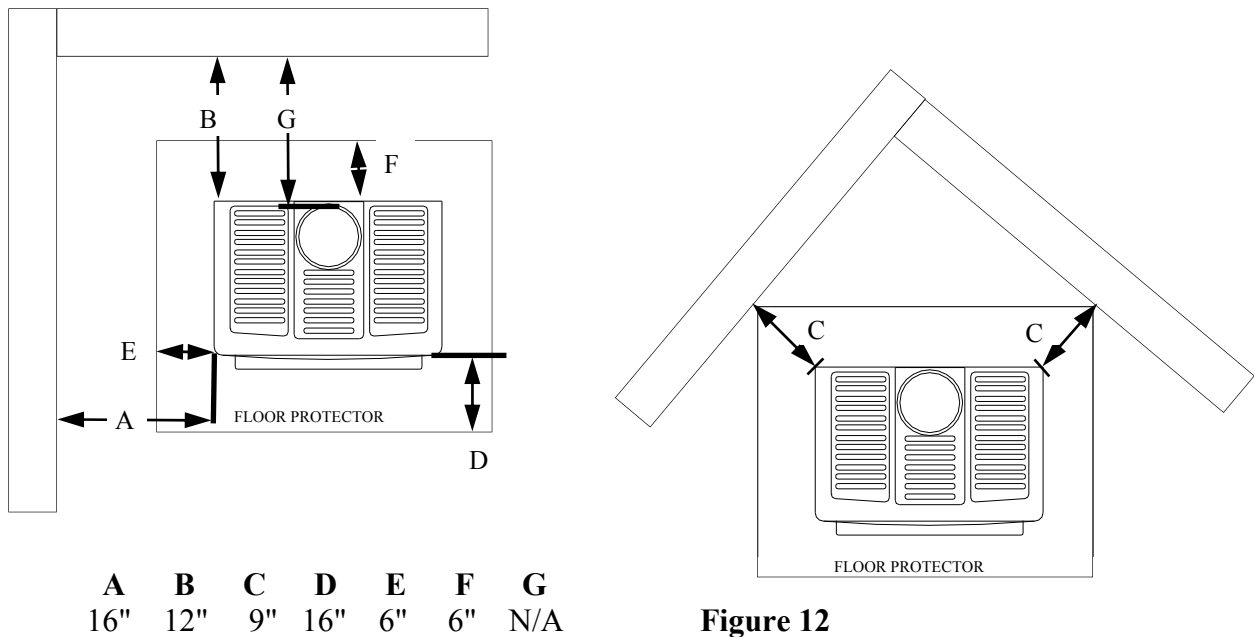

Figure 12

**ALCOVE INSTALLATION CLEARANCES
(CLEARANCES TO BE USED WITH DOUBLE WALL PIPE)**

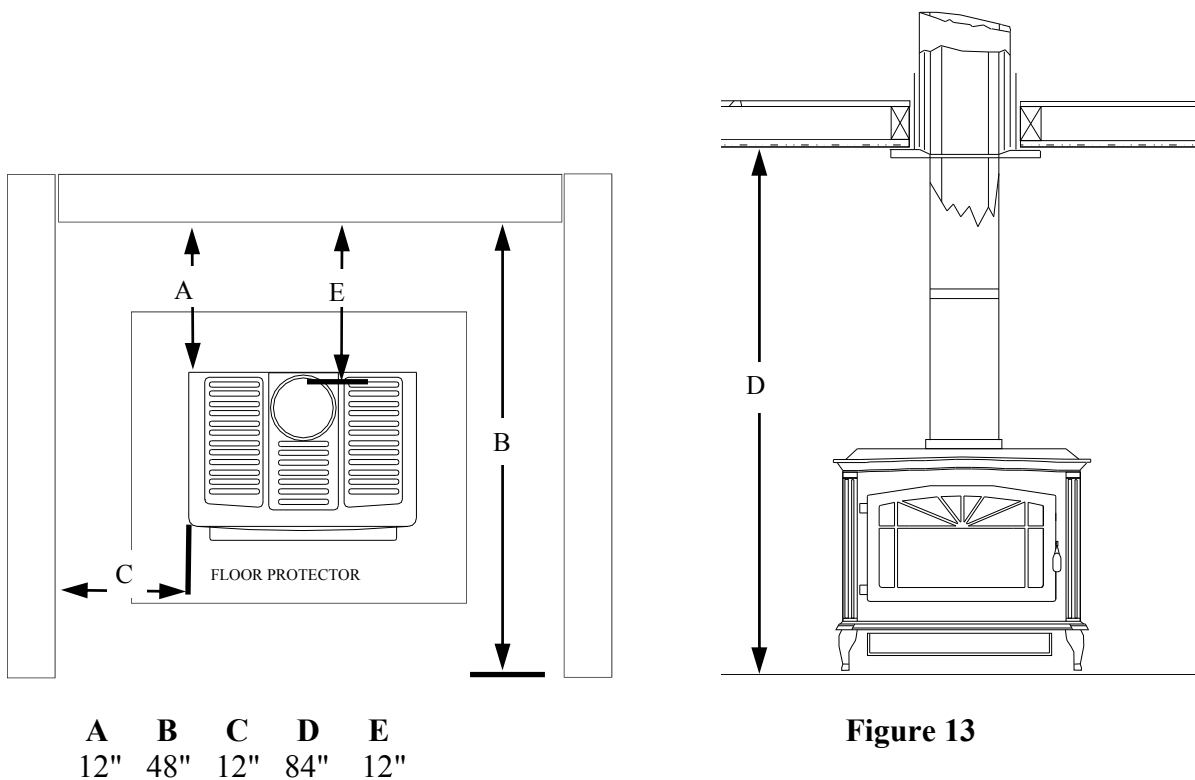

Figure 13

NOTE: SEE YOUR LOCAL DEALER FOR MOBILE HOME INSTALLATION INSTRUCTIONS AND OUTSIDE AIR ADAPTOR KIT. THIS UNIT MAY NOT BE INSTALLED IN A MANUFACTURED (MOBILE) HOME WITHOUT THE PROPER INSTRUCTIONS AND ADAPTOR KIT.

FINAL CHECK

1. Recheck the specified clearances.
2. Remove all foreign material from the firebox area.
3. Open the primary air draft.
4. Place crumpled pieces of newspaper in the stove. Light it and close the doors. Ensure that the stove draws properly through the primary draft.
5. Plug the power cord into a 115 V ac outlet when using with optional motor.
6. Check for smoke leaks around the doors.

CAUTION

Open the doors and check for smoke escaping from the front of the stove. Smoking usually indicates a defective or poorly positioned chimney. Some chimneys with a marginal draft can be preheated by lighting newspaper and holding it near the open damper with a poker or fire tong. Once the chimney heats up, a proper draft can usually be obtained.

If a thorough review of the Troubleshooting Guide in the rear of the manual does not reveal the problem, contact your dealer for assistance.

CAUTION

The unit is painted with a specially formulated high temperature paint that cures during the first two or three firings. You may notice a slight smoking effect and an odor of burning paint when you build the first fires. This is normal and is not a cause for alarm. In some cases, these fumes will activate a smoke alarm. Opening a window near the unit will allow these fumes to escape. DO NOT build a large, roaring fire until this curing is complete or the heater finish may be damaged.

SECTION III

WOOD HEATER SAFETY

Certain safety hazards are inherent in any wood heater installation. You should be aware of these so that a safe and proper installation can be made.

1. **FAULTY CHIMNEY:** An older masonry chimney should be thoroughly checked to be sure there are no holes or weak spots which could allow sparks or hot gases to escape.
2. **HEAT CONDUCTION:** Placing combustible materials too close to a heater or chimney can be a fire hazard.

By keeping these particular hazards in mind as you install and use your room heater you can ensure a safe, reliable installation.

The chimney and chimney connector should be inspected once every two months. Any build-up of soot should be removed to prevent the risk of a chimney fire. To remove chimney or chimney connector: Remove screws or fasteners. Remove pipe and clean with steel brush. Replace chimney or chimney connector, and replace screws and/or fasteners.

CAUTION

NEVER USE GASOLINE, GASOLINE TYPE LANTERN FUEL, KEROSENE, CHARCOAL LIGHTER FLUID OR SIMILAR LIQUIDS TO START OR "FRESHEN UP" A FIRE IN THE HEATER. KEEP ALL SUCH LIQUIDS WELL AWAY FROM THE STOVE WHEN IT IS IN USE. ALL FLUIDS OF THIS TYPE GIVE OFF VOLATILE FUMES AND CAN AND WILL EXPLODE!! DON'T TAKE A CHANCE WITH THE SAFETY OF YOUR HOME AND FAMILY.

DISPOSAL OF ASHES: Ashes should be placed in a metal container with a tight fitting lid. The closed container of ashes should be placed on a non-combustible floor or on the ground, well away from all combustible materials pending final disposal. If the ashes are disposed of by burial in soil or otherwise locally dispersed, they should be retained in the closed container until all cinders have thoroughly cooled. **Ashes can ignite up to 72 hours after removal.**

CREOSOTE-FORMATION AND NEED FOR REMOVAL: When wood is burned slowly, it produces tar and other organic vapors, which combine with expelled moisture to form creosote. The creosote vapors condense in the relatively cool chimney flue of a slow-burning fire. As a result, creosote residue accumulates on the flue lining. When ignited this creosote makes an extremely hot fire.

SECTION IV OPERATION

This section of the manual is to help you get the maximum efficiency and maximum smoke (particulate) reduction from your heater. If you should experience any difficulty or have any questions concerning your heater, contact your dealer for assistance. The manufacturer recommends that for maximum performance burn seasoned hard wood.

Build a fire for maximum efficiency. This heater burns wood and extracts heat so efficiently, a large fire is not necessary. A large fire not only wastes energy, it usually results in the home being too warm for comfort.

The following steps will serve as a guide for operating your stove.

BUILDING A FIRE

1. Open the door.
2. Open the primary air control under hearth, push in. To close pull all the way out.
3. Twist two pieces of non-colored newspaper into a roll and place them on the floor of the firebox.
4. These models are not designed for the use of grates, andirons or other methods of supporting the fuel.
5. Lay several pieces of dry kindling on top of the newspaper.
6. Place three or four small pieces of firewood, 2-3" in diameter, on top of the kindling.
7. Light the newspaper in the front. Close and latch the door. Don't leave the fire unattended at this point. The draft system of the heater should start quickly. It may be necessary to preheat the chimney to get the draft started. To do this, open the door and add newspaper to the top rear of the wood. Light or let this paper ignite and allow to burn while holding the door slightly cracked. Once the draft has started, close and lock the door. You are over heating the unit if the chimney and or connector glows red.
8. After embers and a coal bed have been established, load the heater with wood.

NOTE: THE FUELING DOOR MUST REMAIN CLOSED DURING OPERATION.

ASH REMOVAL INSTRUCTIONS:

Main door to Firebox

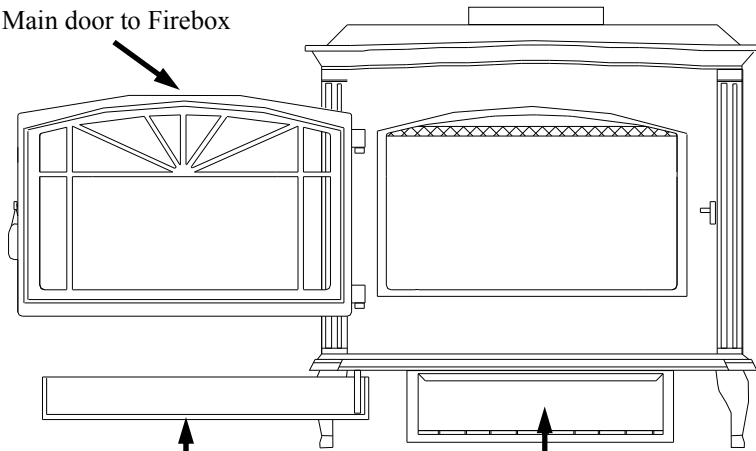

(1) Open access cover door under main door to firebox, to gain access to the ash pan holder door.

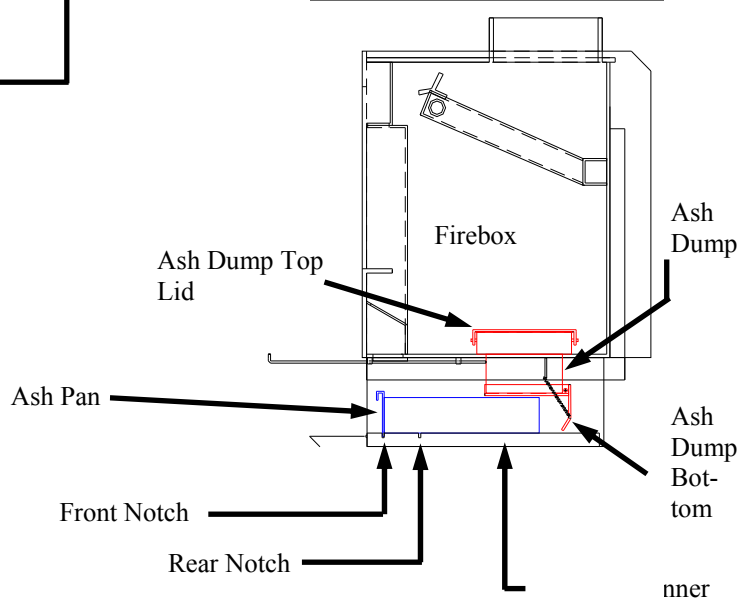

(2) Lift ash pan out of the front notch and slide back until it clears the front notch and rests on the runners. Then push back until it drops into the rear notch.

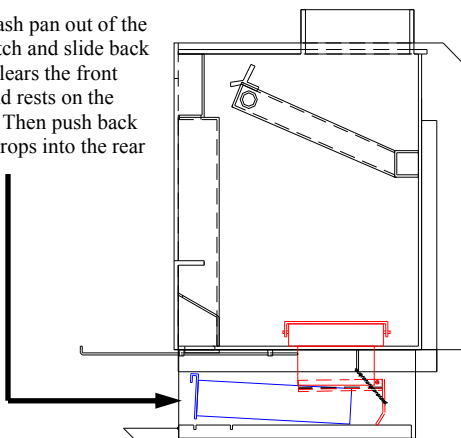

- (3) Open main door to firebox. Locate ash dump top lid in right rear of heater. Open ash dump top lid and sweep ashes into ash dump channel. When finished, close top lid and lift ash pan out of rear notch. Remove ash pan from ash pan holder and dispose of ashes properly.
- (4) Replace ash pan in ash pan holder.
- (5) Close main firebox door.

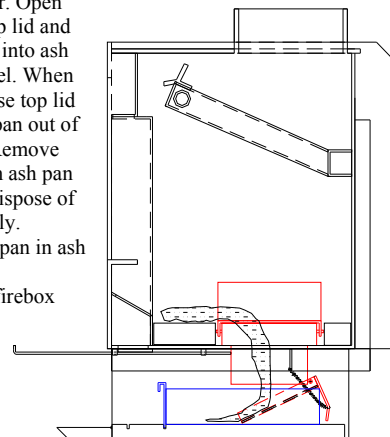

OPTIONAL ROOM AIR BLOWER (#MA T3714) INSTALLATION:

The MA T3714 Optional Room Blower kit:

- [1] Remove the three (3) phillips head screws on the rear of the heater, and remove the air channel shield.
- [2] There are two (2) wires attached to the blower motor with connectors on the ends. Push the two (2) wires through the round 5/8" hole located in the bottom of the back panel of the heater. Continue to push the wires up the outer back of the firebox on the right rear side until they come to the top of the air channel opening.
- [3] Next take the thermostat provided with the kit and connect the two wires from the blower to the terminals on the thermostat.
- [4] Push the thermostat into the thermostat bracket located on the right rear side of the heater between the outer back of the firebox and the rear back panel.
- [5] Align the motor channel with the opening located in the bottom of the back panel of the heater. Push the motor channel end into the opening. Align the four (4) holes in the mounting brackets with the four (4) holes in the back panel and secure the brackets to the back panel with the four hex head screws provided with the blower kit.

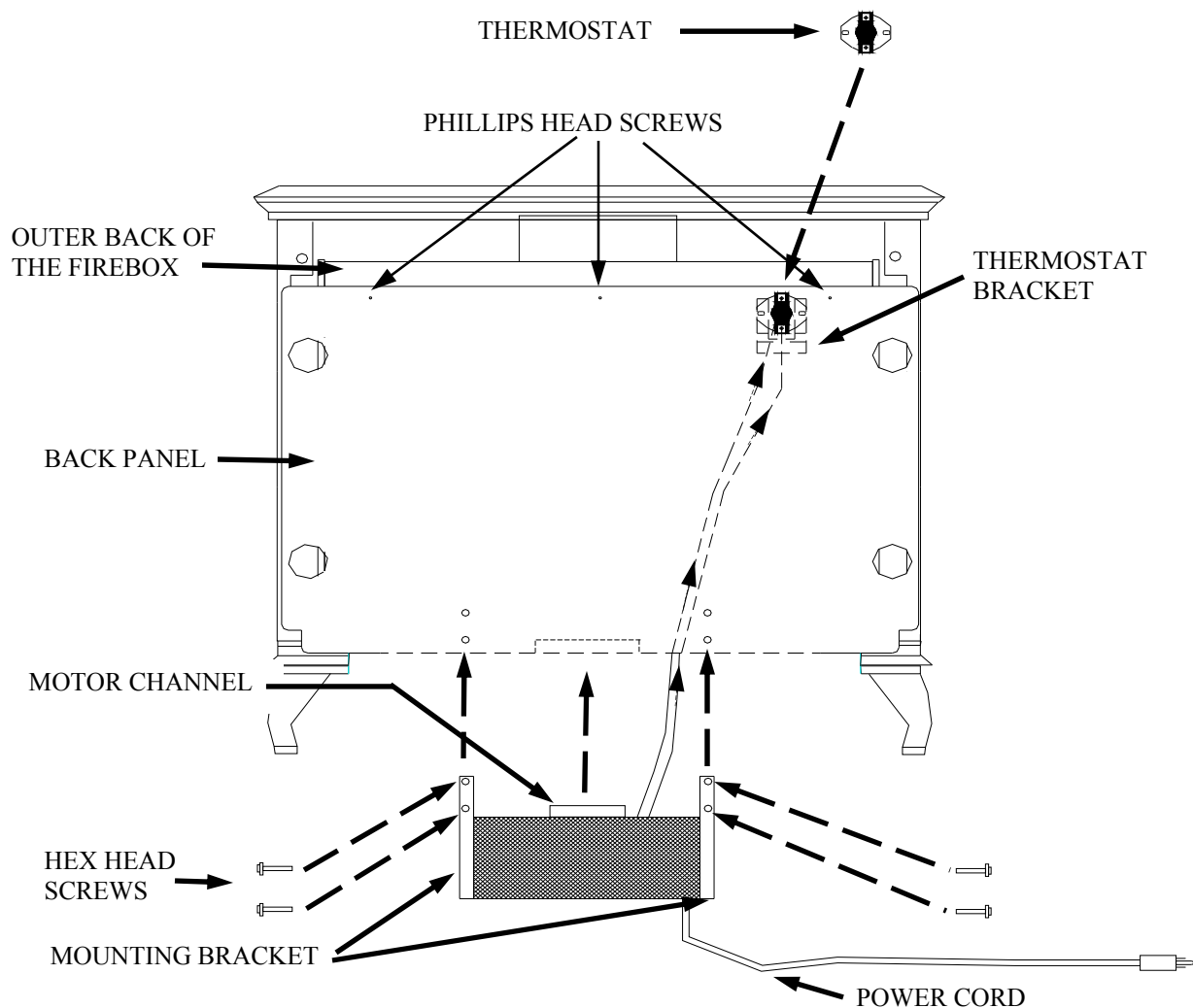

WIRING DIAGRAM:

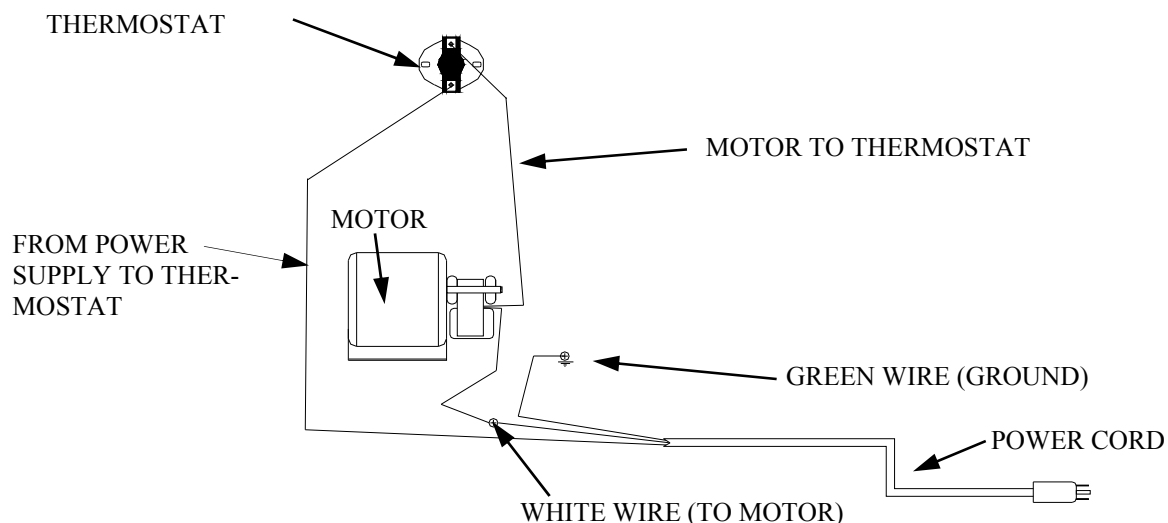

NOTE: If any of the original wire as supplied with the stove must be replaced, it must be replaced with type 16 ga., 105 C. rating wire or its equivalent.

WARNING: ELECTRICAL GROUNDING INSTRUCTION: THIS APPLIANCE IS EQUIPPED WITH A THREE-PRONG (GROUNDING) PLUG FOR YOUR PROTECTION AGAINST SHOCK HAZARD AND SHOULD BE PLUGGED DIRECTLY INTO A PROPERLY GROUNDED THREE-PRONG RECEPTACLE. DO NOT CUT OR REMOVE THE GROUNDING PRONG FROM THIS PLUG.

REPLACEMENT PARTS:

THERMOSTAT # PE 400132

BLOWER MOTOR #PE 42-40-01

POWER CORD # PE 400240

FOR ADDITIONAL PARTS CONTACT: NEW BUCK CORPORATION

P.O. BOX 69
SPRUCE PINE, NC 28777
(PHONE) 828-765-6144

**SECTION VIII
TROUBLESHOOTING**

PROBLEM	POSSIBLE CAUSE	SOLUTION
1. Sluggish Heater	1. Obstruction in Chimney 2. Manual damper in chimney is closed 3. Wet or unseasoned wood being burned 4. Poor chimney draft	1. Check for and remove obstruction 2. Open manual damper and wire shut with stainless steel wire or remove damper 3. Burn dry seasoned wood 4. Improper chimney height or wrong size flue is being used. Cooler temperatures caused by external chimney.
2. High fuel consumption	1. Improper regulation of draft or inlet air 2. Improper door fitting	1. (a) Close inlet air control as much as possible to maintain desired heat output. (b) Check gaskets, reinstall fiberglass gasketing around doors and glass as necessary 2. Check door gasket, check adjustment of door latch
3. Backpuffing	1. Gusts of Wind	1. Chimney may need wind diverter. Raise chimney for better draft.
4. Smoke rollout when heater door is opened	1. Wind gusts blowing down the chimney 2. Opening heater door too fast	1. Chimney may need wind diverter. Raise chimney for better draft. 2. Crack door for 15 seconds before fully opening door.

NEW BUCK CORPORATION (NBC)
"LIMITED WARRANTY" FOR THE BUCK STOVE
PLEASE READ THIS WARRANTY CAREFULLY

PRODUCTS COVERED

This warranty covers the New Buck Corp. Model 21 Cast Iron Insert/Townsend III heating unit, so long as it is owned by the original purchaser, including optional and standard accessories purchased at the same time, subject to terms, limitations, and conditions herein set out.

PRODUCTS NOT COVERED

This warranty does not cover the following:

- Glass;
- Refractory material such as refractory cement or firebrick;
- Gaskets.

This Warranty will also not cover any damage and/or failure caused by abuse or improper installation of the products covered.

WARRANTY TIME PERIODS

(A) Period I

For one year from the date of purchase, NBC will replace or repair, at its option, any part defective in materials or workmanship. The costs of parts only are included. The customer pays any labor or transportation charges required.

Thereafter

B) Period II

For the period after the first year from the date of purchase and extending for 5 years as long as the Buck Stove is owned by the original purchaser, NBC will repair or replace, at its option, any part defective in materials or workmanship, with the exception of: electrical motors, wiring, switches, and components: optional and standard accessories; and all parts not permanently attached to the heating unit. Parts not permanently attached to the heating unit are defined as those items designed to be removed from the stove, including those removable with common hand tools. The costs of parts only are included. The customer pays any labor or transportation charges required.

PROCEDURE

Should you feel that your Buck Stove is defective, you should contact any Buck Stove dealer for the name of your nearest authorized Buck Stove service representative, who will instruct you on the proper procedure, depending on which Warranty Time Period (Period I or Period II) applies.

If for any reason you are dissatisfied with the suggested procedures, you may contact us in writing at:

New Buck Corporation
Customer Service Department
P. O. Box 69
Spruce Pine, NC 28777

CONDITIONS AND EXCLUSIONS

- A. Replacement of parts may be in the form of new or fully reconditioned parts, at NBC's option.
- B. There is no other express warranty. All implied warranties of Merchantability and Fitness for Use are limited to the duration of the Express Warranty.
- C. New Buck Corporation is not liable for indirect, incidental, or consequential damages in connection with the use of the product including any cost or expense of providing substitute equipment or service during periods of malfunction or non-use.
Some states do not allow the exclusion of incidental or consequential damages, so the above exclusion may not apply to you.
- D. All warranty repairs under this warranty must be performed by an authorized Buck Stove service representative. Repairs or attempted repairs by anyone other than an authorized service representative are not covered under this warranty. In addition, these unauthorized repairs may result in additional malfunctions, the correction of which is not covered by warranty.

OTHER RIGHTS

This warranty gives you specific legal rights, and you may also have other rights, which vary from state to state.